



US010488027B2

(12) **United States Patent**
May

(10) **Patent No.:** **US 10,488,027 B2**

(45) **Date of Patent:** **Nov. 26, 2019**

(54) **CONNECTOR SYSTEM FOR LIGHTING ASSEMBLY**

FOREIGN PATENT DOCUMENTS

(71) Applicant: **Michael W. May**, Crystal Lake, IL (US)

CN 2548014 Y 4/2003
CN 2573866 Y 9/2003

(Continued)

(72) Inventor: **Michael W. May**, Crystal Lake, IL (US)

OTHER PUBLICATIONS

(*) Notice: Subject to any disclaimer, the term of this patent is extended or adjusted under 35 U.S.C. 154(b) by 0 days.

Extended European search report issued in European Application No. 12873713.7-1757 dated Jan. 29, 2016 (9 pages).

(Continued)

(21) Appl. No.: **16/394,995**

Primary Examiner — Elmito Breval

(22) Filed: **Apr. 25, 2019**

(74) *Attorney, Agent, or Firm* — Fitch, Even, Tabin & Flannery LLP

(65) **Prior Publication Data**

US 2019/0249856 A1 Aug. 15, 2019

Related U.S. Application Data

(63) Continuation of application No. 15/401,537, filed on Jan. 9, 2017, now Pat. No. 10,302,292.
(Continued)

(51) **Int. Cl.**
F21V 23/06 (2006.01)
F21V 29/74 (2015.01)
(Continued)

(52) **U.S. Cl.**
CPC **F21V 23/06** (2013.01); **F21K 9/20** (2016.08); **F21K 9/272** (2016.08); **F21K 9/278** (2016.08);
(Continued)

(58) **Field of Classification Search**
None
See application file for complete search history.

(56) **References Cited**

U.S. PATENT DOCUMENTS

1,516,721 A 11/1924 Emery
1,941,079 A 12/1933 Exelmans
(Continued)

(57) **ABSTRACT**

A support connector for maintaining an end of a linear LED lamp in an operative state on a support. The support connector comprises a nonconductive housing comprising a first portion including a mounting base at one end of the first portion configured to couple the support connector to the support. A second portion extends from the opposite end of the first portion and is configured to be insertable within an opening of a first end cap assembly of the linear LED lamp. First and second power electrical terminals are disposed within first and second receptacles of the support connector, and a grounding electrical terminal is disposed within a third receptacle, and the grounding electrical terminal is electrically isolated from the first and second power terminals. The first and second power electrical terminals mate with first and second conductive power pins of the end cap assembly, and the grounding electrical terminal is configured to mate with a grounding pin of the end cap assembly as the first end cap assembly is moved relative to the support connector from a position fully separated from the support connector in a path that is transverse to the length of the body into an engaged position.

23 Claims, 15 Drawing Sheets

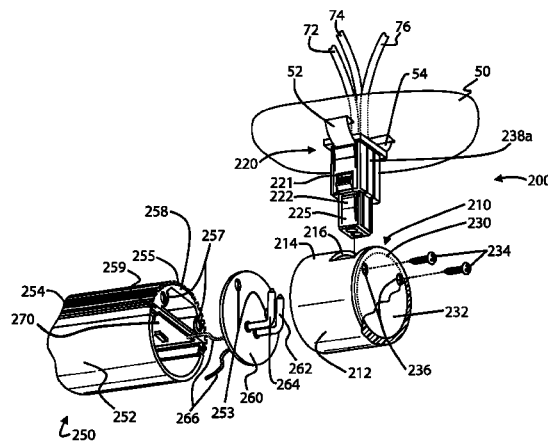

Related U.S. Application Data

(60) Provisional application No. 62/276,075, filed on Jan. 7, 2016, provisional application No. 62/422,521, filed on Nov. 15, 2016.

(51) **Int. Cl.**

F21V 19/00 (2006.01)
F21V 21/002 (2006.01)
F21V 23/02 (2006.01)
F21V 23/00 (2015.01)
F21V 15/015 (2006.01)
H01R 33/08 (2006.01)
H01R 13/627 (2006.01)
F21V 29/89 (2015.01)
F21K 9/272 (2016.01)
F21K 9/278 (2016.01)
F21K 9/20 (2016.01)
F21Y 103/10 (2016.01)
F21K 9/66 (2016.01)
F21V 3/02 (2006.01)
F21Y 115/10 (2016.01)

(52) **U.S. Cl.**

CPC *F21V 15/015* (2013.01); *F21V 19/0085* (2013.01); *F21V 21/002* (2013.01); *F21V 23/001* (2013.01); *F21V 23/02* (2013.01); *F21V 29/74* (2015.01); *F21V 29/89* (2015.01); *H01R 13/6273* (2013.01); *H01R 33/0845* (2013.01); *F21K 9/66* (2016.08); *F21V 3/02* (2013.01); *F21Y 2103/10* (2016.08); *F21Y 2115/10* (2016.08)

(56)

References Cited

U.S. PATENT DOCUMENTS

2,137,174 A 11/1938 Marshaus
 2,628,800 A 2/1953 Kindorf et al.
 3,052,864 A 9/1962 Gaynor
 3,087,982 A 4/1963 Hayes
 3,131,871 A 5/1964 Foulds
 3,404,268 A 10/1968 Fowler
 D246,930 S 1/1978 Win
 4,115,230 A 9/1978 Beckman
 4,156,553 A 5/1979 Ammon et al.
 5,106,103 A 4/1992 Fiore
 5,434,762 A 7/1995 Shemitz
 5,457,905 A 10/1995 Kaplan
 5,624,274 A 4/1997 Lin
 D397,481 S 8/1998 Schafer
 5,855,487 A 1/1999 Kunishi
 5,947,761 A 9/1999 Pepe
 D421,815 S 3/2000 Herst et al.
 D430,326 S 8/2000 Littman
 6,107,572 A 8/2000 Miyazaki
 D438,326 S 2/2001 Kan
 6,231,373 B1 5/2001 Daoud
 6,257,735 B1 7/2001 Baar
 6,283,612 B1 9/2001 Hunter
 6,350,158 B1 2/2002 Arnett et al.
 D459,012 S 6/2002 Shemitz et al.
 D459,517 S 6/2002 Shemitz et al.
 6,548,967 B1 4/2003 Dowling et al.
 6,561,828 B2 5/2003 Henrici
 6,577,080 B2 6/2003 Lys et al.
 6,578,979 B2 6/2003 Truttmann-Battig
 6,623,151 B2 9/2003 Pederson
 6,676,425 B2 1/2004 Lewis
 D500,883 S 1/2005 Herst et al.
 D500,884 S 1/2005 O'Rourke
 D503,009 S 3/2005 Salman
 6,969,954 B2 11/2005 Lys
 7,049,761 B2 5/2006 Timmermans et al.

D523,165 S 6/2006 Schultz
 7,195,370 B2 3/2007 Riblett et al.
 D543,305 S 5/2007 Wang
 7,309,965 B2 12/2007 Dowling et al.
 D565,785 S 4/2008 Kerr
 D574,105 S 7/2008 Shuai et al.
 7,393,223 B1 7/2008 Koda
 D575,898 S 8/2008 Tran et al.
 D581,569 S 11/2008 Levine
 7,448,892 B2 11/2008 Dowdle
 7,476,004 B2 1/2009 Chan
 D589,199 S 3/2009 Pedersen
 7,507,001 B2 3/2009 Kit
 7,510,299 B2 3/2009 Timmermans et al.
 7,513,637 B2 4/2009 Kelly et al.
 7,559,790 B2 7/2009 Boeck et al.
 7,587,289 B1 9/2009 Sivertsen
 D605,343 S 12/2009 Watt
 D607,145 S 12/2009 Yu
 7,637,636 B2 12/2009 Zheng et al.
 D616,382 S 5/2010 Lin et al.
 7,712,918 B2 5/2010 Siemiet et al.
 7,815,338 B2 10/2010 Siemiet et al.
 D627,095 S 11/2010 Miyairi et al.
 D634,470 S 3/2011 Hsieh
 7,918,580 B2 4/2011 Liu
 7,926,975 B2 4/2011 Siemiet et al.
 7,938,562 B2 5/2011 Ivey et al.
 7,946,729 B2 5/2011 Ivey et al.
 D642,326 S 7/2011 Leadford et al.
 7,976,185 B2 7/2011 Uang et al.
 7,976,187 B2 7/2011 Villard
 7,976,196 B2 7/2011 Ivey et al.
 7,989,827 B2 8/2011 Hsu
 8,011,794 B1 9/2011 Sivertsen
 D649,282 S 11/2011 McDonald et al.
 8,052,295 B2 11/2011 Kim et al.
 8,093,823 B1 1/2012 Ivey et al.
 D654,208 S 2/2012 Marquardt et al.
 8,118,447 B2 2/2012 Simon et al.
 8,164,281 B2 4/2012 Warton
 8,186,847 B2 5/2012 Hu et al.
 8,203,260 B2 6/2012 Li et al.
 8,214,084 B2 7/2012 Ivey et al.
 8,235,539 B2 8/2012 Thomas et al.
 8,247,985 B2 8/2012 Timmermans et al.
 8,251,544 B2 8/2012 Ivey et al.
 8,256,924 B2 9/2012 Simon et al.
 8,282,247 B2 10/2012 Ivey et al.
 8,287,144 B2 10/2012 Pedersen et al.
 8,313,212 B1 11/2012 Mayer et al.
 8,322,878 B2 12/2012 Hsia
 8,324,817 B2 12/2012 Ivey et al.
 8,330,381 B2 12/2012 Langovsky
 8,344,641 B1 1/2013 Isaacson et al.
 8,360,599 B2 1/2013 Ivey et al.
 8,382,327 B2 2/2013 Timmermans et al.
 8,398,253 B2 3/2013 Sivertsen
 8,408,742 B2 4/2013 Tran
 D682,463 S 5/2013 Bernard
 8,434,891 B1 5/2013 Ham
 8,444,292 B2 5/2013 Ivey et al.
 8,454,193 B2 6/2013 Simon et al.
 8,523,394 B2 9/2013 Simon et al.
 8,534,873 B1 9/2013 Soderman et al.
 D691,750 S 10/2013 Mackiewicz
 D692,597 S 10/2013 Simon et al.
 8,547,036 B2 10/2013 Tran
 8,556,452 B2 10/2013 Simon et al.
 8,558,413 B1 10/2013 Lepard
 8,560,261 B1 10/2013 Sivertsen
 8,571,716 B2 10/2013 Ivey et al.
 8,573,813 B2 11/2013 Ivey et al.
 8,596,813 B2 12/2013 Ivey
 8,616,720 B2 12/2013 Carney et al.
 D698,075 S 1/2014 Klus
 8,628,216 B2 1/2014 Ivey et al.
 8,643,298 B2 2/2014 Palazzolo et al.
 8,653,984 B2 2/2014 Ivey et al.

(56)

References Cited

U.S. PATENT DOCUMENTS

D701,639 S 3/2014 Maxik et al.
 8,664,880 B2 3/2014 Ivey et al.
 8,674,626 B2 3/2014 Siemiet et al.
 8,678,610 B2 3/2014 Simon et al.
 8,702,265 B2 4/2014 May
 8,710,759 B1 4/2014 Isaacson et al.
 8,742,680 B2 6/2014 Cowburn
 8,807,785 B2 8/2014 Ivey et al.
 8,827,486 B2 9/2014 Lai
 8,830,080 B2 9/2014 Ivey et al.
 8,836,476 B2 9/2014 Campbell et al.
 8,866,414 B2 10/2014 Maxik et al.
 8,915,756 B2 12/2014 Schumacher et al.
 8,919,991 B2 12/2014 Lee et al.
 8,941,330 B2 1/2015 Ng et al.
 8,956,005 B2 2/2015 Thomas et al.
 8,956,019 B2 2/2015 Swedberg
 8,967,825 B2 3/2015 Fukui
 9,080,760 B1 7/2015 Soderman et al.
 9,101,028 B2 8/2015 Isaacson et al.
 9,155,171 B1 10/2015 Hughes et al.
 9,215,755 B2 12/2015 Saur et al.
 9,228,727 B2 1/2016 May
 9,247,623 B2 1/2016 Recker et al.
 9,285,085 B2 3/2016 Carney et al.
 9,295,142 B1 3/2016 Leinen et al.
 9,295,144 B2 3/2016 Bora et al.
 9,307,621 B1 4/2016 Parello et al.
 9,328,882 B2 5/2016 Spiro
 9,338,860 B2 5/2016 Radermacher
 9,391,415 B2 7/2016 Swedberg
 9,464,791 B2 10/2016 May
 9,464,792 B2 10/2016 May
 9,464,793 B2 10/2016 May
 9,470,401 B2 10/2016 May
 9,671,071 B1 6/2017 May
 9,671,072 B1 6/2017 May
 9,739,427 B1 8/2017 May
 2002/0047646 A1 4/2002 Lys
 2002/0096347 A1 7/2002 Pyron
 2004/0095078 A1 5/2004 Leong
 2006/0012981 A1 1/2006 Noh
 2007/0159828 A1 7/2007 Wang
 2007/0246714 A1 10/2007 Koike et al.
 2007/0258202 A1 11/2007 Cooley
 2008/0197790 A1 8/2008 Mangiaracina
 2010/0003860 A1 1/2010 Mateo Ferrus et al.
 2010/0039813 A1 2/2010 Sloan et al.
 2010/0072921 A1 3/2010 Weatherley
 2010/0079075 A1 4/2010 Son
 2010/0112845 A1 5/2010 Lam et al.
 2010/0190455 A1 7/2010 Hashizume
 2010/0254148 A1 10/2010 Huang et al.
 2010/0327768 A1 12/2010 Kong et al.
 2011/0019421 A1 1/2011 Lai
 2011/0199005 A1 8/2011 Bretschneider et al.
 2011/0199769 A1 8/2011 Bretschneider et al.
 2011/0235321 A1 9/2011 Ivey et al.
 2011/0280020 A1 11/2011 Chen et al.
 2011/0292647 A1 12/2011 Chang
 2012/0049739 A1 3/2012 Clough
 2012/0069557 A1 3/2012 Bolscher
 2012/0147598 A1 6/2012 Ivey
 2012/0201022 A1 8/2012 Van de Ven et al.
 2012/0229025 A1 9/2012 Edwards, Jr. et al.
 2012/0307524 A1 12/2012 Schapira
 2013/0002164 A1 1/2013 Galluccio et al.
 2013/0119896 A1 5/2013 Fukano
 2013/0135851 A1 5/2013 Ham, II
 2013/0141906 A1 6/2013 Wang et al.
 2013/0147367 A1 6/2013 Cowburn
 2013/0258668 A1 10/2013 Dellian et al.
 2013/0264942 A1 10/2013 Kuang
 2013/0265746 A1 10/2013 May
 2013/0279160 A1 10/2013 Myers et al.

2013/0329414 A1 12/2013 Kusunose
 2013/0343037 A1 12/2013 Alexander
 2014/0009926 A1 1/2014 Simon
 2014/0056009 A1 2/2014 Swedberg
 2014/0133400 A1 5/2014 Ruan et al.
 2014/0146529 A1 5/2014 Xu
 2014/0218905 A1 8/2014 Ono et al.
 2014/0226322 A1 8/2014 Chan
 2014/0268752 A1 9/2014 Werr et al.
 2014/0293595 A1 10/2014 May
 2015/0049475 A1 2/2015 Pan et al.
 2015/0316214 A1 11/2015 Baumeister et al.
 2015/0351205 A1 12/2015 Clark et al.
 2016/0227629 A1 8/2016 Conner et al.
 2017/0023193 A1 1/2017 Thosteson et al.
 2017/0198896 A1 7/2017 May

FOREIGN PATENT DOCUMENTS

CN 1690505 A 11/2005
 CN 101122379 A 2/2008
 CN 201093403 Y 7/2008
 CN 201448641 U 5/2010
 CN 201636803 U 11/2010
 CN 101936469 A 1/2011
 CN 102032534 A 4/2011
 CN 103946630 A 7/2014
 CN 104584332 A 4/2015
 EP 2418422 A2 2/2012
 FR 2675958 10/1992
 JP S6144785 3/1986
 JP 2007165051 A 6/2007
 JP 200884856 4/2008
 JP 2012230864 11/2012
 JP 3185411 8/2013
 WO 2009143047 A2 11/2009
 WO 2013121580 A1 8/2013
 WO 2013151565 10/2013

OTHER PUBLICATIONS

Notification of Transmittal of the International Search Report and the Written Opinion of the International Searching Authority, for International Application No. PCT/US2017/12700, dated Jul. 19, 2018.

Notification of Transmittal of the International Search Report and the Written Opinion of the International Searching Authority, or the Declaration from the International Bureau of WIPO for International Application No. PCT/US15/26409, dated Jul. 30, 2015, 17 pages.

Notification of Transmittal of the International Search Report and the Written Opinion of the International Searching Authority, or the Declaration from the International Bureau of WIPO for International Application No. PCT/US17/12700, dated Mar. 31, 2017, 16 pages.

Notification of Transmittal of the International Search Report and the Written Opinion of the International Searching Authority, or the Declaration from the International Bureau of WIPO for International Application No. PCT/US2012/037242, dated Aug. 13, 2012, 13 pages.

Office Action including Search Report issued in Chinese Application No. 2012800737587 dated Jan. 28, 2016 (8 pages).

Office Action issued in Japanese Application No. 2017-506639 dated Jun. 12, 2018 (19 pgs.).

Extended European search report issued in European Application No. 15779891.9-1757 dated Jan. 23, 2018 (11 pages).

Notice of Restriction issued in related Chinese Application No. 201580031681.0 dated Jun. 30, 2017 and English translation (8 pages).

Notification Concerning Transmittal of International Preliminary Report on Patentability and Written Opinion of the International Searching Authority from the International Bureau of WIPO issued in International Application No. PCT/US2015/026409, dated Oct. 27, 2016.

(56)

References Cited

OTHER PUBLICATIONS

Notification of Transmittal of the International Search Report and the Written Opinion of the International Searching Authority, or the Declaration from the International Bureau of WIPO for International Application No. PCT/US17/17151, dated Jun. 7, 2017 (12 pages).

Notification of Transmittal of the International Search Report and the Written Opinion of the International Searching Authority, or the Declaration from the International Bureau of WIPO for International Application No. PCT/US17/17189, dated Jun. 7, 2017 (13 pages).

Office Action including Search Report issued in Chinese Application No. 2015800316810 dated Jan. 19, 2018 (9 pages).

Partial Supplementary European search report issued in European Application No. 15779891.9-1757 dated Sep. 18, 2017 (13 pages).

Extended European search report dated Aug. 29, 2019, issued in related European Application No. 17736504 (14 pages).

Ohinese First Office Action dated Sep. 6, 2019, issued in corresponding Chinese Patent Application No. 201780014847.7, with English translation (13 pages).

FIG. 1
(Prior Art)

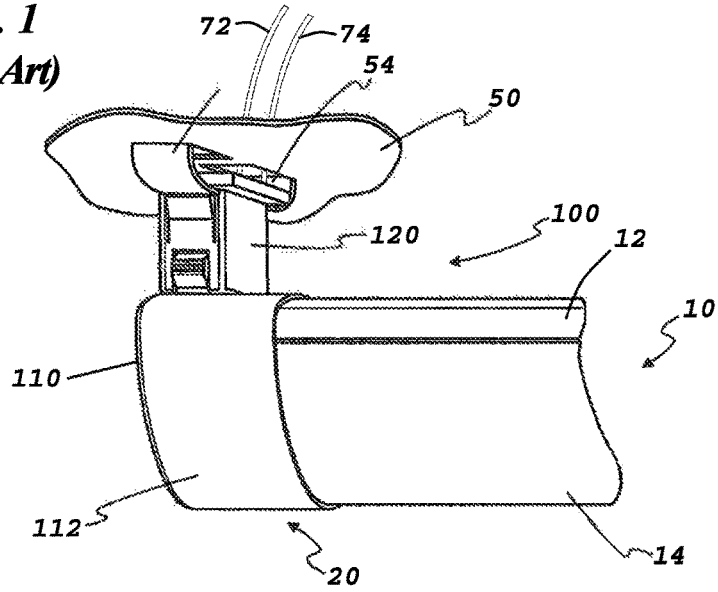

FIG. 2
(Prior Art)

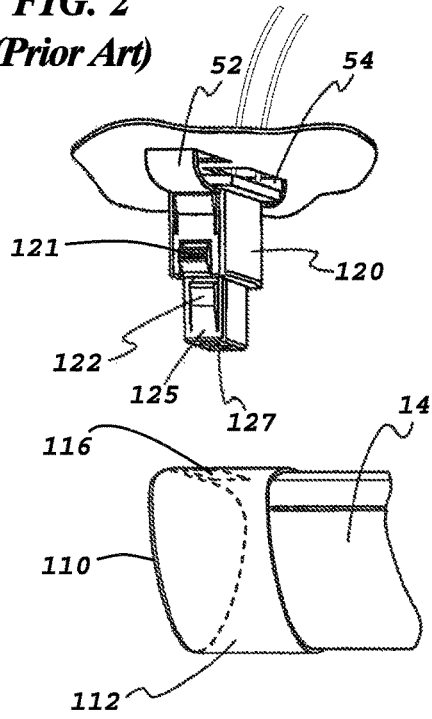

FIG. 3
(Prior Art)

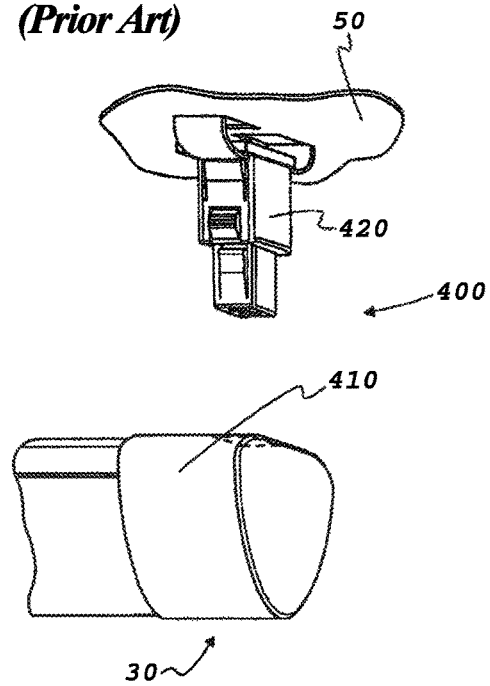

FIG. 4
(Prior Art)

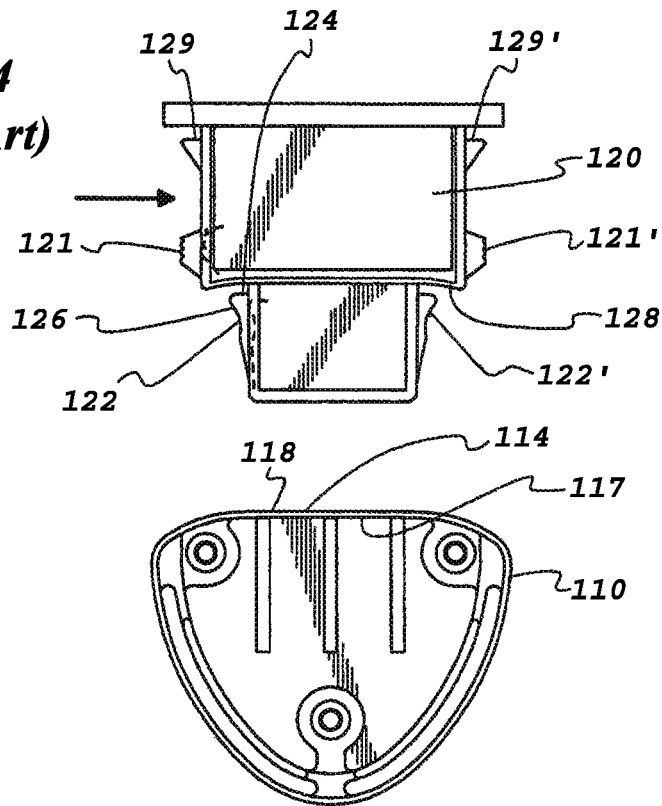

FIG. 5
(Prior Art)

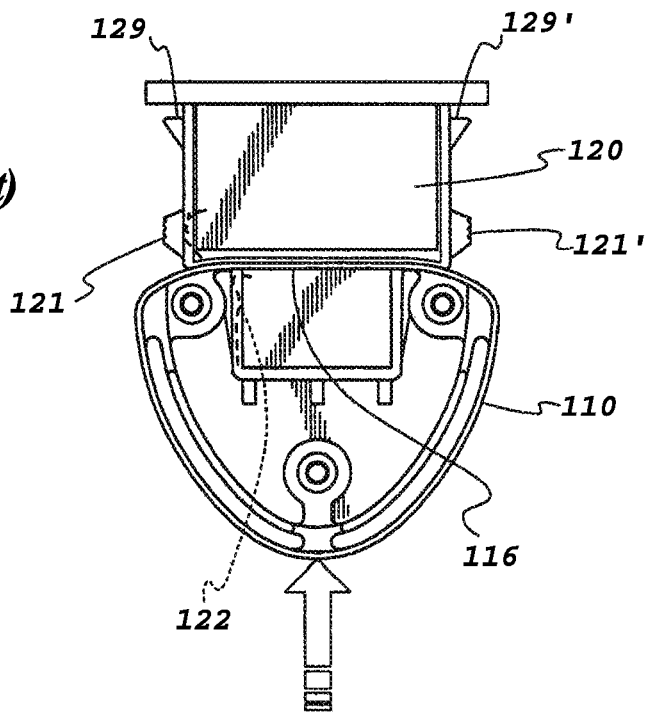

FIG. 6
(Prior Art)

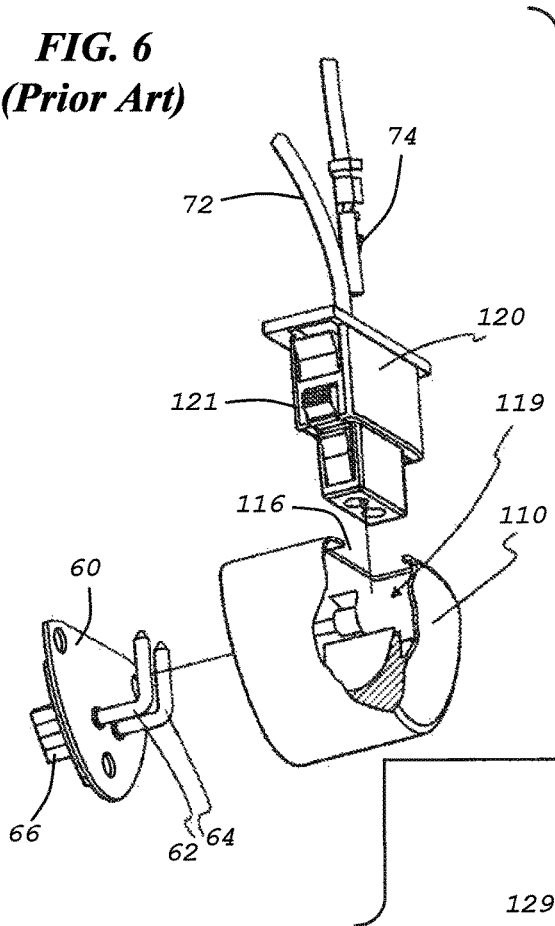
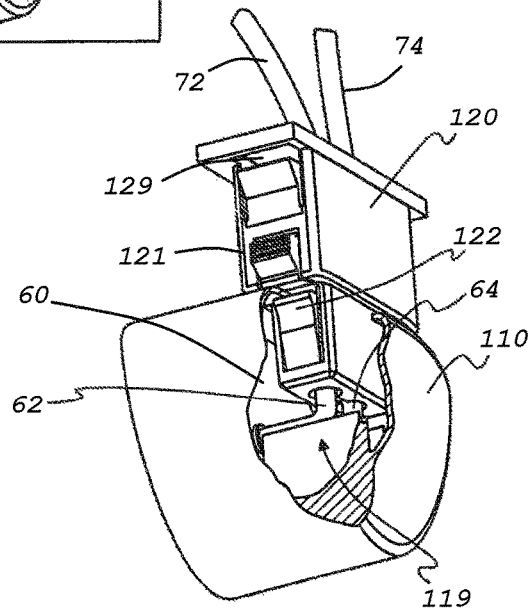
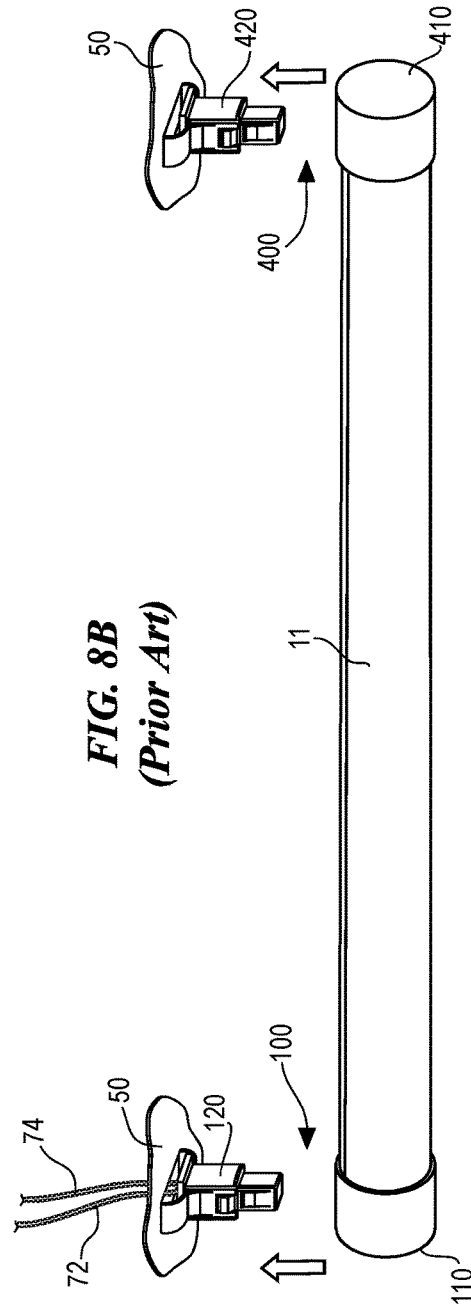
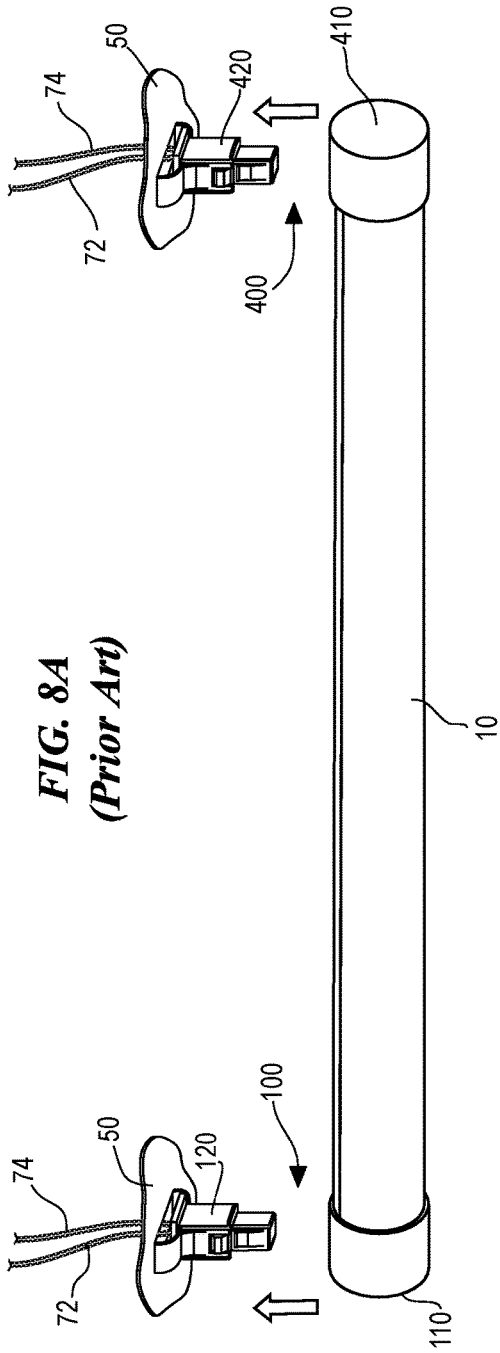

FIG. 7
(Prior Art)





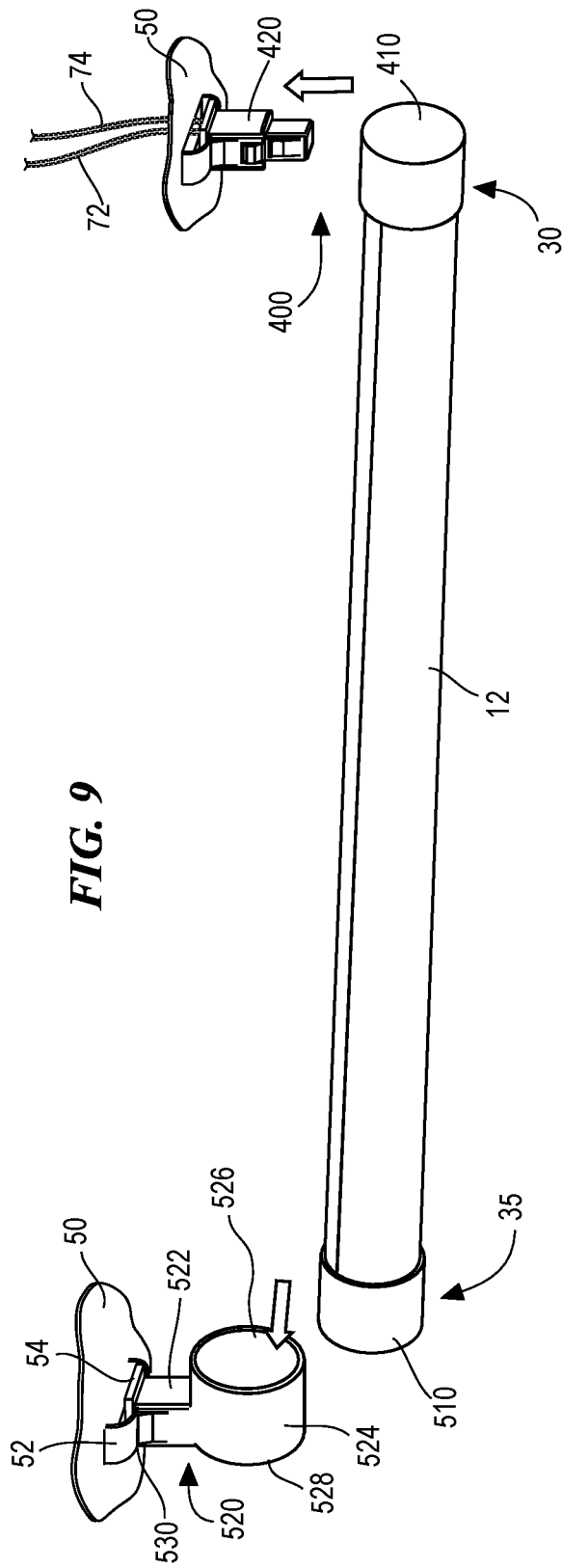

FIG. 10

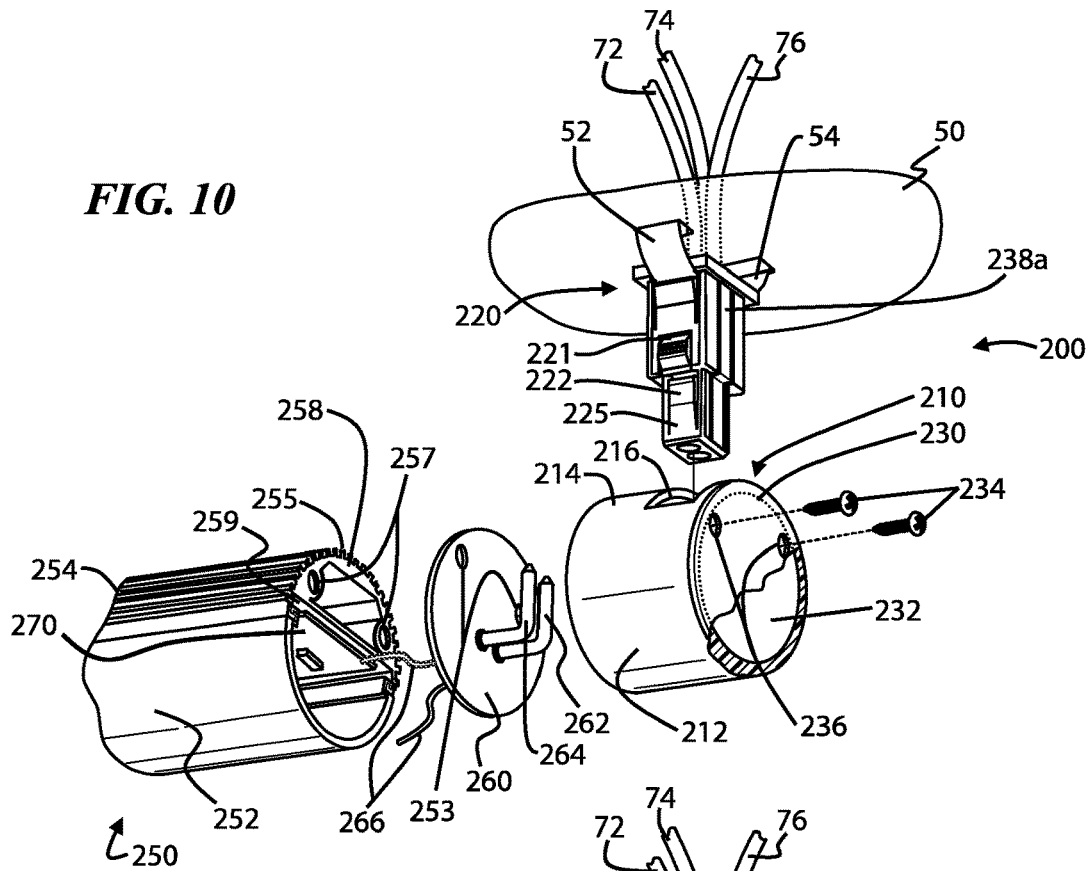

FIG. 11

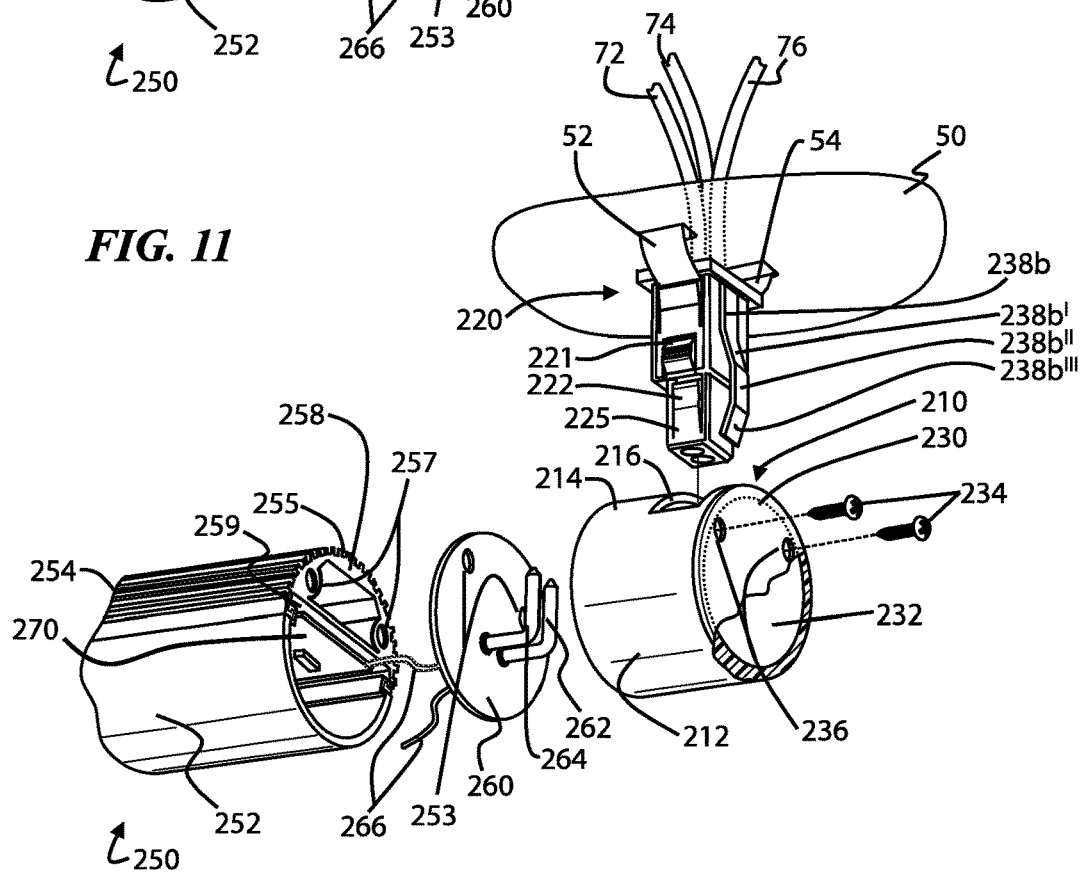

FIG. 12

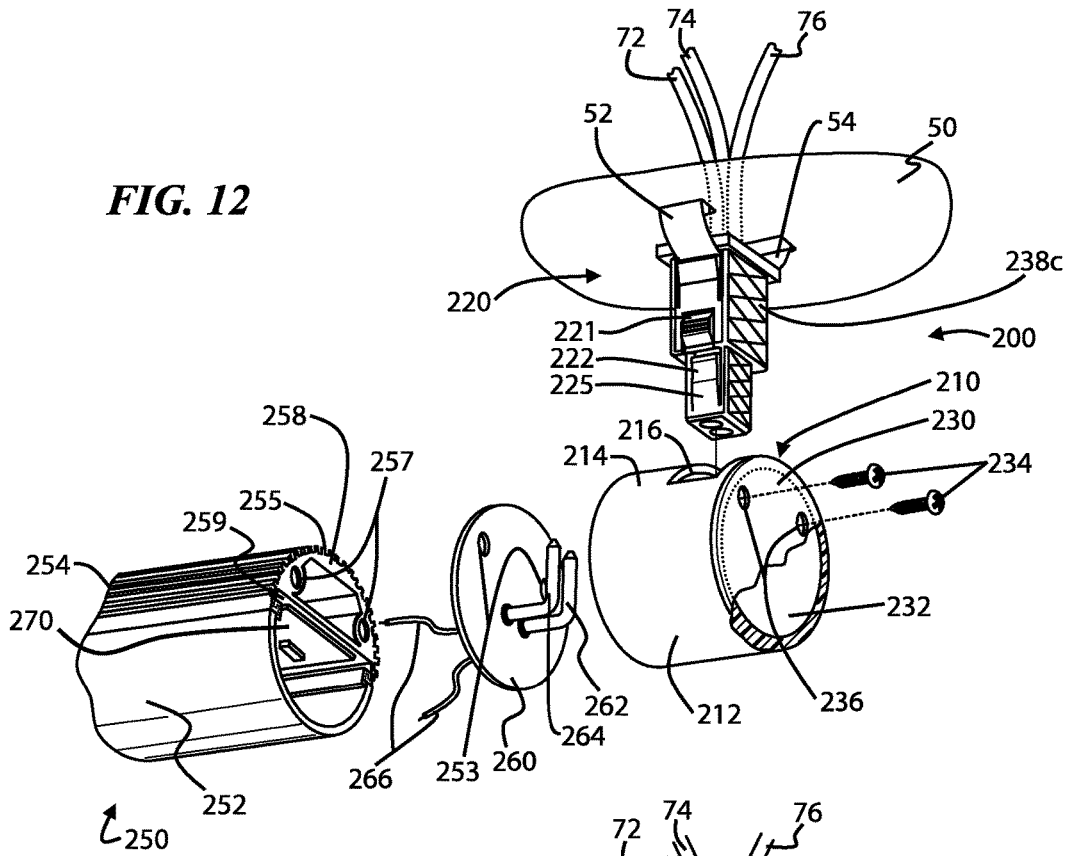

FIG. 13

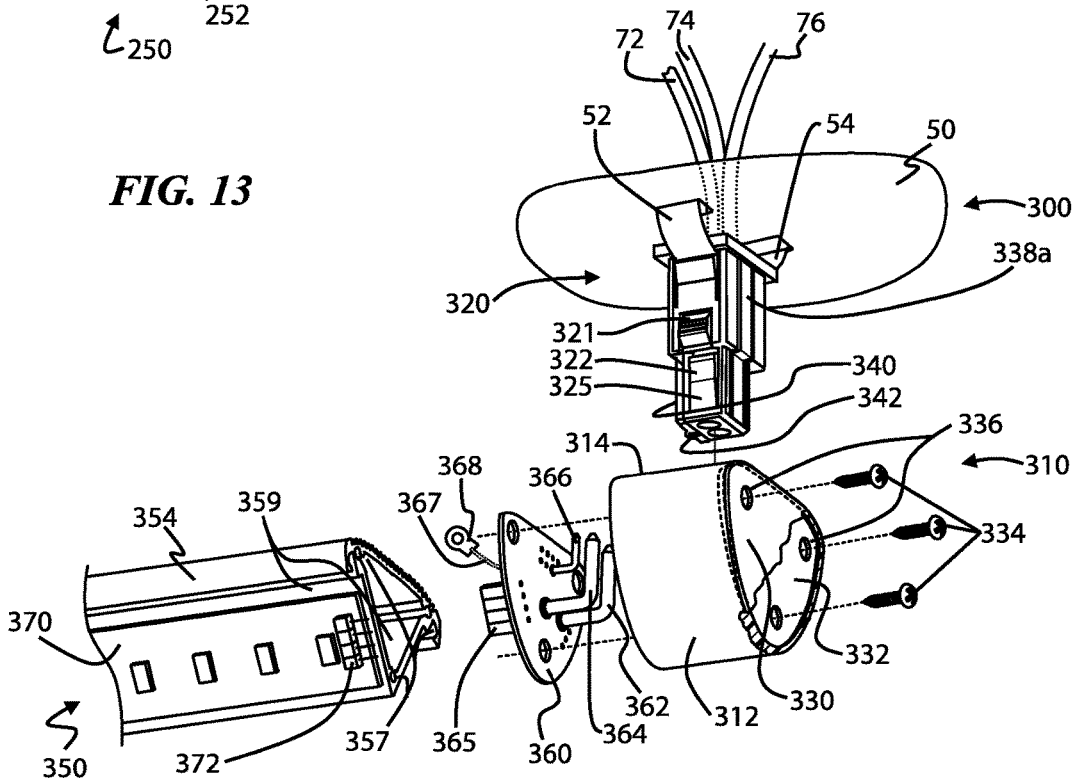

FIG. 14

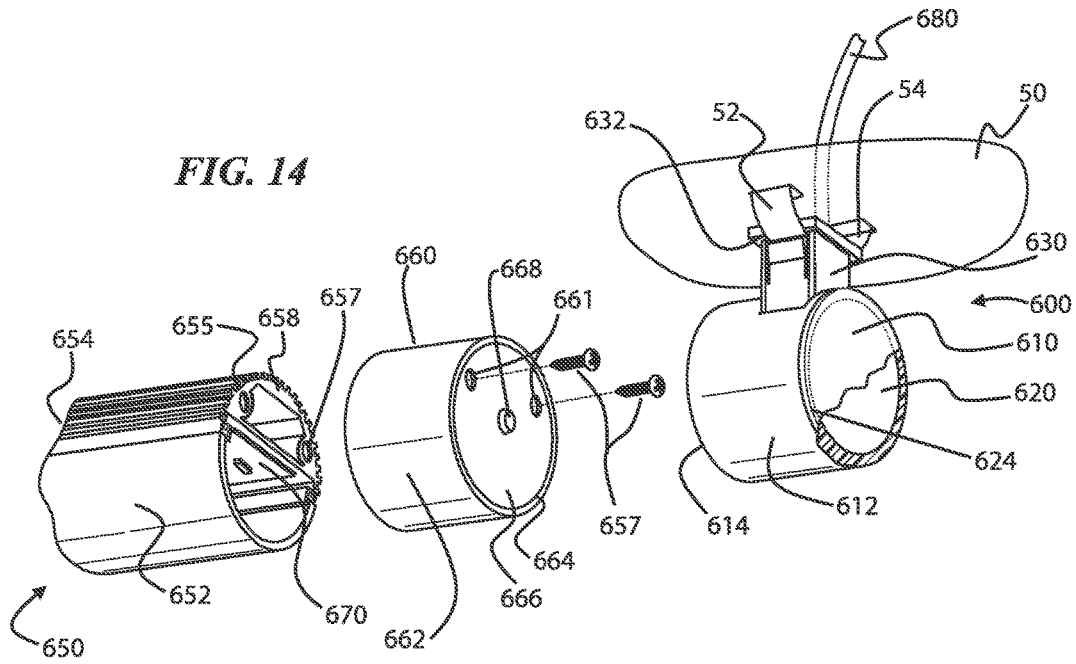
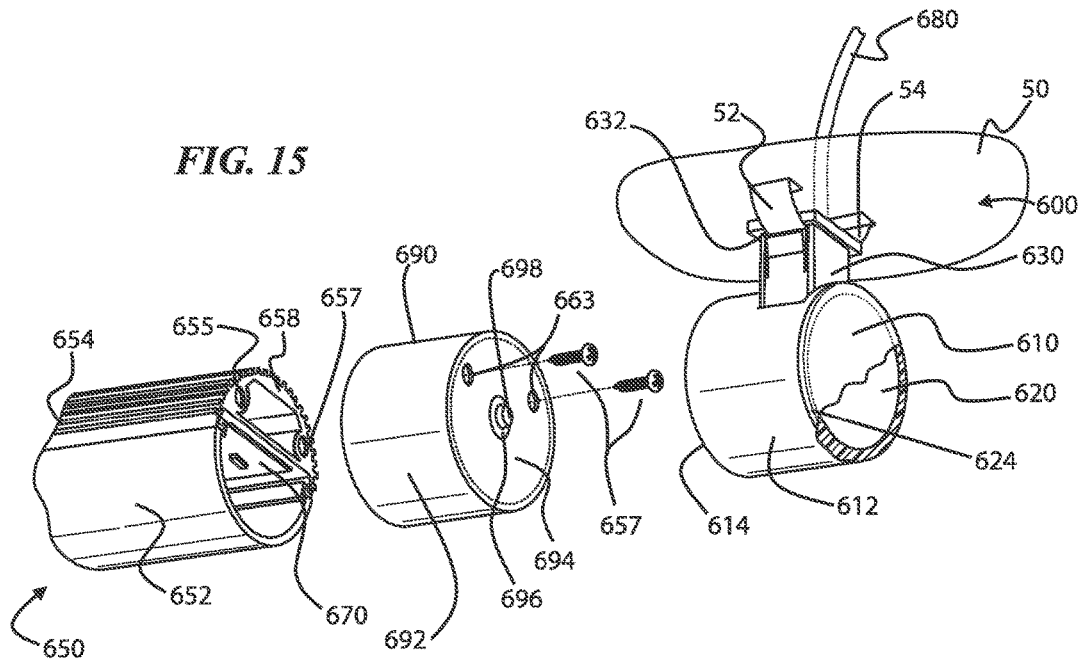

FIG. 15



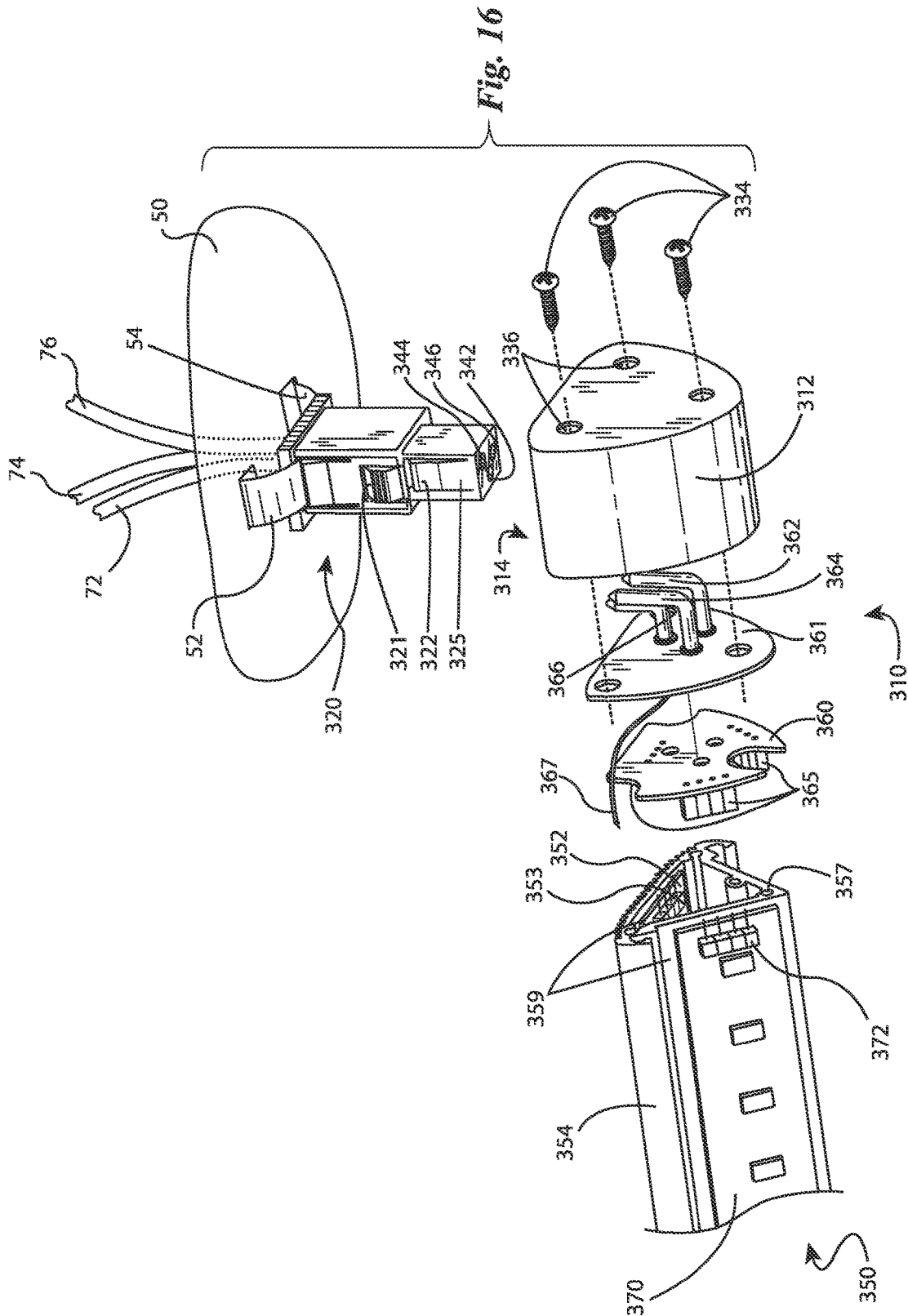

FIG. 18

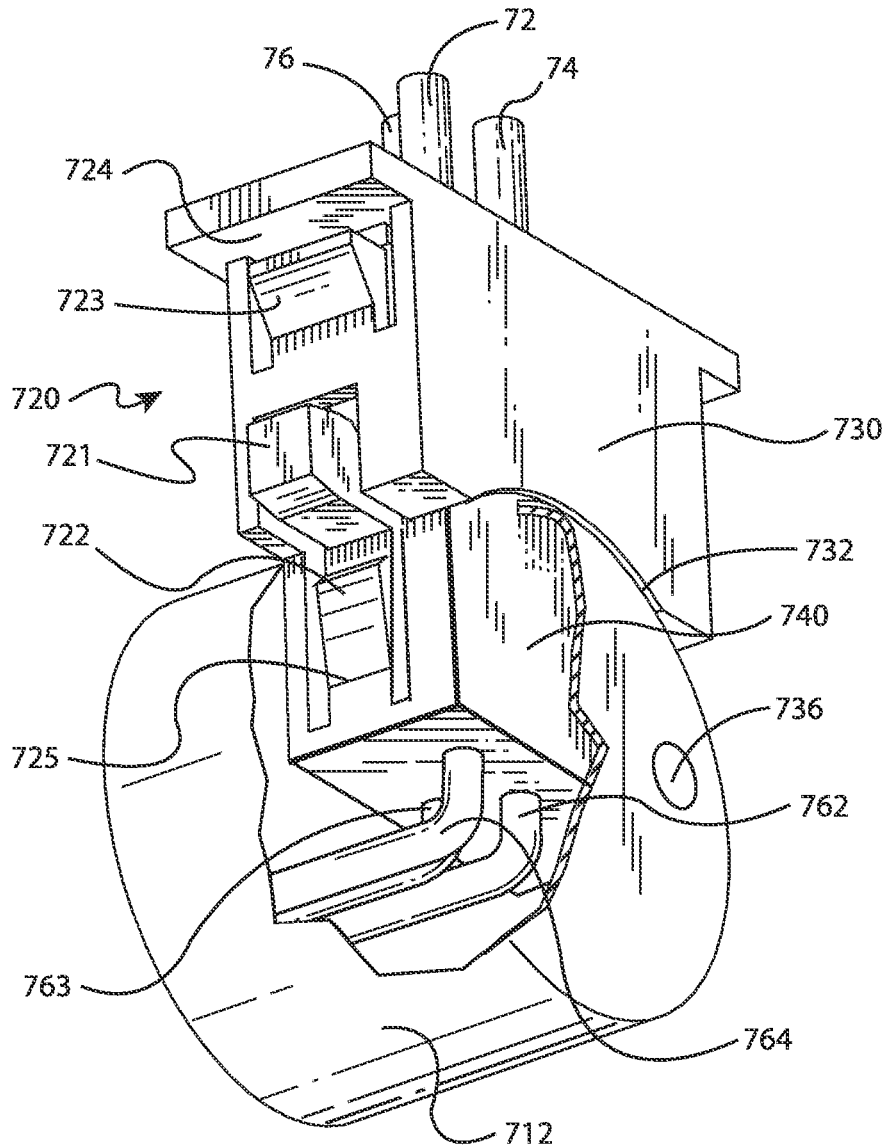

FIG. 19a

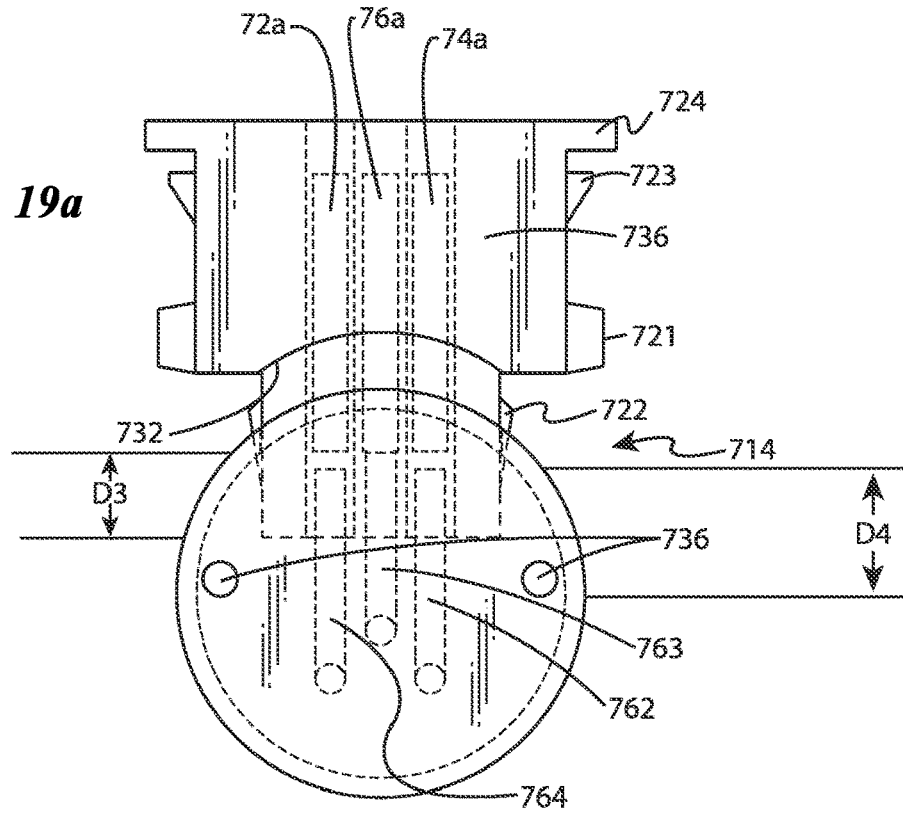

FIG. 19b

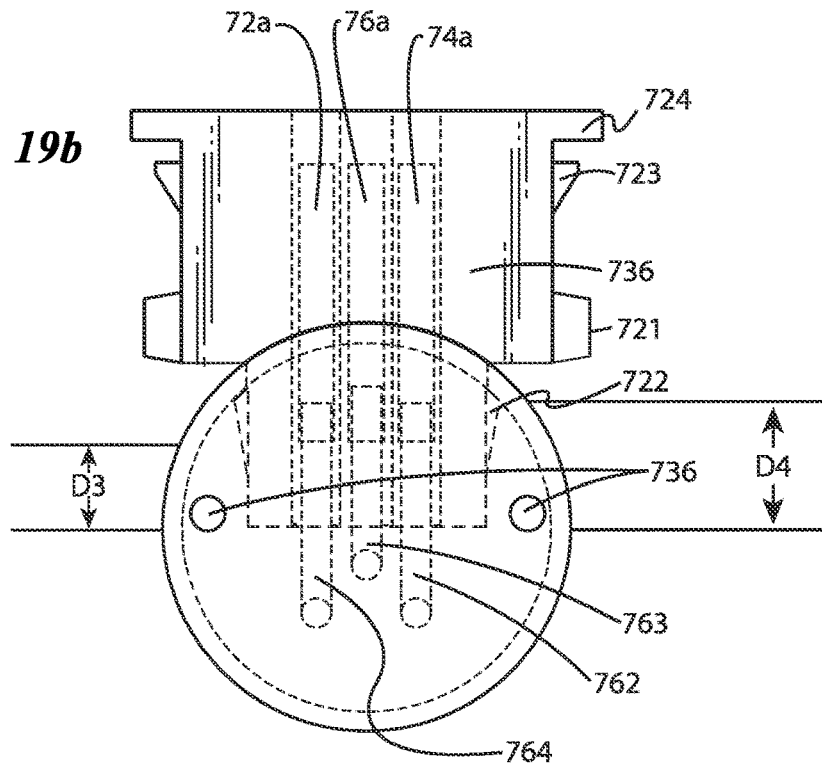

FIG. 20a

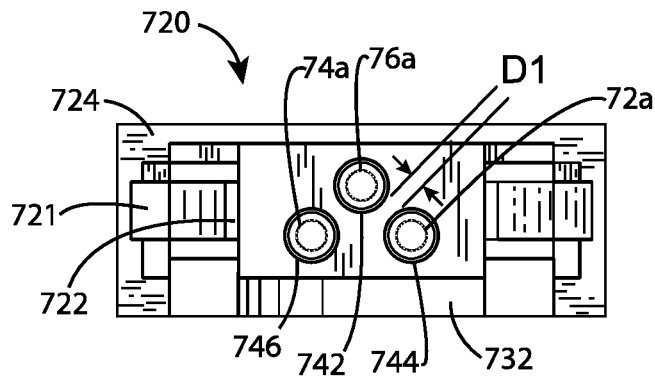

FIG. 20b

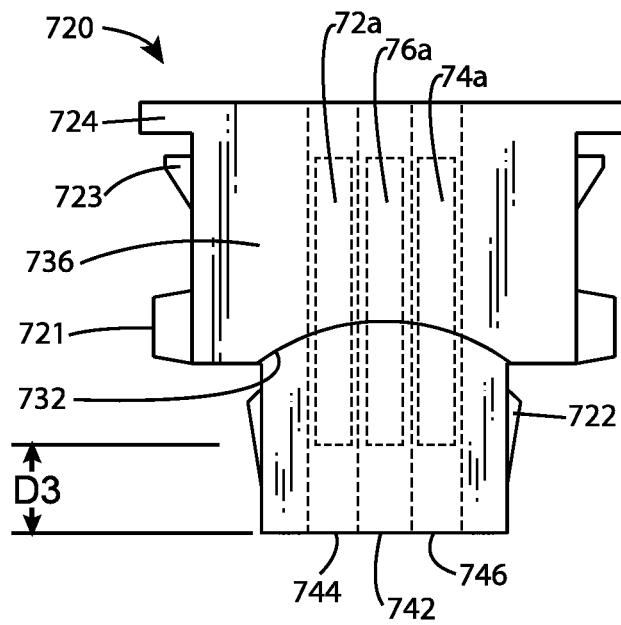

FIG. 21a

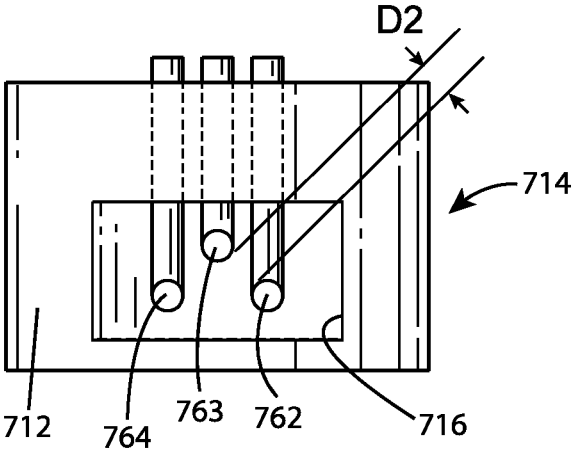
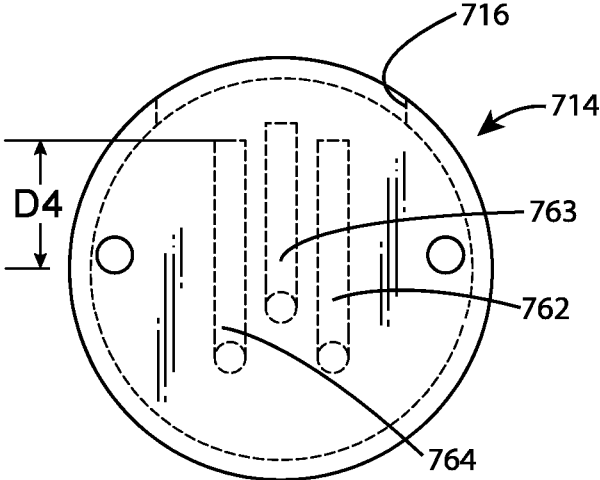
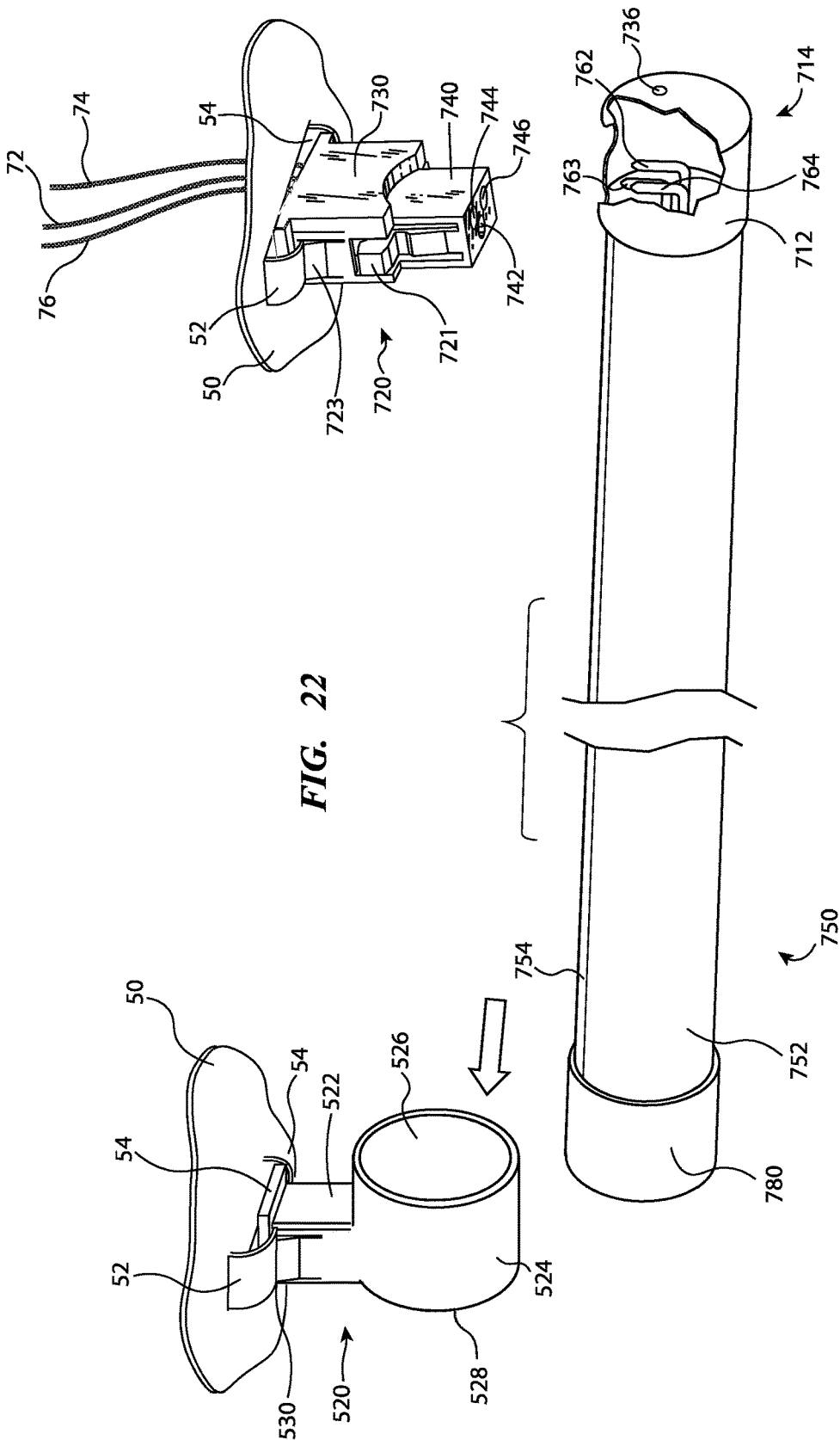

FIG. 21b





CONNECTOR SYSTEM FOR LIGHTING ASSEMBLY

CROSS-REFERENCE TO RELATED APPLICATIONS

This application is a continuation application of U.S. patent application Ser. No. 15/401,537, entitled "Connector System For Lighting Assembly" and filed Jan. 9, 2017, which claims the benefit of U.S. Provisional Patent Application No. 62/276,075, entitled "Connector System For Lighting Assembly" and filed Jan. 7, 2016, and U.S. Provisional Patent Application No. 62/422,521, entitled "Connector System For Lighting Assembly" and filed Nov. 15, 2016, which are hereby incorporated by reference in their entirety herein.

FIELD

This invention relates to lighting and, more particularly, to light emitting diode (LED) illumination as well as tubular lighting assemblies.

BACKGROUND

Over the years various types of illuminating assemblies and devices have been developed for indoor and/or outdoor illumination, such as torches, oil lamps, gas lamps, lanterns, incandescent bulbs, neon signs, fluorescent bulbs, halogen lights, and light emitting diodes. These conventional prior art illuminating assemblies and devices have met with varying degrees of success.

Incandescent light bulbs create light by conducting electricity through a thin filament, such as a tungsten filament, to heat the filament to a very high temperature so that it glows and produces visible light. Incandescent light bulbs emit a yellow or white color. Incandescent light bulbs, however, are very inefficient, as a high percentage of energy input is lost as heat.

Fluorescent lamps conduct electricity through mercury vapor, which produces ultraviolet (UV) light. The ultraviolet light is then absorbed by a phosphor coating inside the lamp, causing it to glow, or fluoresce. While the heat generated by fluorescent lamps is much less than its incandescent counterparts, energy is still lost in generating the UV light and converting UV light into visible light. If the lamp breaks, exposure to mercury can occur. Linear fluorescent lamps are often five to six times the cost of incandescent bulbs but have life spans around 10,000 and 20,000 hours. Some fluorescent lights flicker and the quality of the fluorescent light tends to be a harsh white due to the lack of a broad band of frequencies. Most fluorescent lights are not compatible with dimmers.

Conventional fluorescent lights typically utilize a bi-pin/2-pin means on the tubular body that mechanically supports the body in an operative state on lamp holders of the ceiling lighting fixture and effects electrical connection of the illumination source to a power supply. A ballast associated with the lighting fixture converts AC line voltage to the DC power provided to the fluorescent tube. The ballast also reduces the power supply to a voltage level suitable for use in a fluorescent tube. A starter circuit for providing a voltage pulse is needed to cause current to conduct through the ionized gas in the fluorescent tube.

Light emitting diode (LED) lighting is particularly useful. Light emitting diodes (LEDs) offer many advantages over incandescent and fluorescent light sources, including: lower

energy consumption, longer lifetime, improved robustness, smaller size, faster switching, and excellent durability and reliability. LEDs emit more light per watt than incandescent light bulbs. LEDs can be tiny and easily placed on printed circuit boards. LEDs activate and turn on very quickly and can be readily dimmed. LEDs emit a cool light with very little infrared light. LEDs come in multiple colors which are produced without the need for filters. LEDs of different colors can be mixed to produce white light.

The operational life of some white LED lamps is 100,000 hours, which is much longer than the average life of an incandescent bulb or fluorescent lamp. Another important advantage of LED lighting is reduced power consumption. An LED circuit will approach 80% efficiency, which means 80% of the electrical energy is converted to light energy; the remaining 20% is lost as heat energy. Incandescent bulbs, however, operate at about 20% efficiency with 80% of the electrical energy lost as heat.

Linear LED tube lighting products for replacing fluorescent lighting typically comprise an array of LEDs mounted on one or more circuit boards. The LED boards are mounted on an elongate heat sink comprising a heat conducting material such as aluminum. The LED circuit boards are in thermal contact with the heat sink, but electrically isolated from the heat sink. The LED tube lamp may include internal driver module containing circuitry for converting AC line current to DC current and controlling the voltage applied to the LEDs. The internal driver circuitry can be designed specifically to meet the electrical requirements of the LED circuit boards, thus overcoming potential problems associated with using the existing local ballast originally designed for powering fluorescent lamps. In some designs, however, an external local ballast is used. The high power LEDs, as well as any internal driver module, generate heat that must be dissipated by the heat sink. To facilitate heat dissipation to the atmosphere, the heat sink is typically disposed such that its external surface forms a portion of the outer surface of the tube lighting assembly. The lighting assembly is installed such that the heat sink faces upward toward the ceiling lighting fixture. The remaining circumference of the tube comprises a translucent or transparent lens cover through which the generated light is emitted. The lens cover faces towards the space to be illuminated when the LED lighting assembly is installed in a ceiling or other lighting fixture.

The linear LED lamp heat sink is typically fabricated of an electrically conductive metallic material such as aluminum or aluminum alloys. These materials dissipate heat efficiently without a significant increase in surface temperature. The heat sink itself, as well as the printed circuit LED boards and other electrical components within the linear LED tube assembly, present a safety hazard without proper electrical grounding. This is because the line voltage or voltage input to the LED boards could be applied to the heat sink in the event of a short circuit, for example, if the insulation between the LEDs and/or internal driver circuitry and the heat sink is inadequate or deteriorates during use. This could lead to other components within the assembly overheating and creating a fire hazard. It also creates an electrical shock hazard should the user come into physical contact with the heat sink when inspecting the installed lamp. The electrical components within the lamp, such as LEDs and driver circuits, are also susceptible of being damaged in the event of a power surge. With the recent introduction of sensors, cameras, control and data communications circuitry and other "smart lighting" components

into linear LED lamp formats, a comprehensive protective grounding system is required.

One type of LED tube lamp is designed for the insert and rotate type lamp holders mounted on conventional fluorescent ceiling lighting fixtures, known in the industry as “tombstone” lamp holders. Such lamp holders are designed to engage electrical power pins projecting in cantilever fashion from the ends of a cylindrical shaped fluorescent tube lamp, or LED replacement tube lamp. The exposed pins on the ends of the linear LED tube are susceptible to damage during distribution and installation. The lamp body must be situated in a first angular orientation to direct the pins into the lamp holders mounted on a support/reflector and is thereafter turned to effect mechanical securement and electrical connection. Installation requires a precise initial angular orientation of the body and subsequent controlled repositioning thereof to simultaneously seat the pins at the opposite ends of the body. Often one or more of the pins are misaligned during this process so that electrical connection is not established. The same misalignment may cause a compromised mechanical connection whereupon the body may escape from the connectors and drop so that it is damaged or destroyed.

Further, the connectors on the support/reflector are generally mounted in such a fashion that they are prone to flexing. Even a slight flexing of the connectors on the support might be adequate to release the pins at one body end so that the entire body becomes separated. The conventional bi-pin and tombstone lamp holder connector means was created for very lightweight fluorescent lighting and not designed for LED tubular lighting that has additional weight due to the required heat sink and PCB boards. The weight of the body by itself may produce horizontal force components that wedge the connectors on the support/reflector away from each other so that the body becomes precariously situated or fully releases.

U.S. Pat. No. 8,434,891 to Ham proposes a LED tube and socket assembly adapted from the conventional insert and rotate type lamp holder system. The disclosed LED tube features a three pin interface projecting from each end of the tube wherein a middle pin is connected to the heat sink. The lamp holder includes a ground terminal, which receives the middle pin and in turn is connected to an external ground via a ground strap. While this approach provides a grounded heat sink, it does not overcome the above-mentioned problems associated with utilizing external pins in an insert and rotate lamp holder for securing linear LED tube lamps. It does not provide ground protection for the electrical components and circuitry of the lamp.

Moreover, the user is not prevented from inadvertently installing the three-pin lamp ends in a conventional, non-grounded tombstone holder rather than the grounded counterpart replacement holders proposed by Ham. Doing so results in a non-grounded lamp, although visually the installation looks nearly identical to a properly grounded lamp. There is no reliable means of assuring that the holders are replaced and the installation properly performed, and it is difficult to determine by visual inspection whether an installation was performed properly to create a safe grounded system. It is impractical to disassemble the system to check that the conventional fluorescent lamp holders were replaced with grounded lamp holders and that ground straps were connected to the system ground. This presents a significant difficulty for end users, lighting maintenance personnel, building inspectors, safety regulators and others desiring to confirm that replacement LED tube lamps are safely grounded. These difficulties are even more pronounced in

commercial environments, such as retail space, warehouses and office buildings, whose overhead lighting systems may utilize hundreds or even thousands of linear tube lamps.

An alternative snap-fit connector system adapted for LED linear tubes is shown in U.S. Patent Application Publication 2014/0293595, by the same applicant of the subject application, and is incorporated as if reproduced in its entirety herein. The tubular LED lighting assembly has at least one LED emitter board within the body; and first and second connectors respectively at the first and second body ends that are configured to secure the lamp on a support fixture. The first connector has cooperating first and second parts. The first connector part is integrated into an end cap assembly of the lamp body. The second connector part is configured to be on a support for the tubular lighting assembly.

The first and second connector parts respectively have first and second surfaces. As the second connector parts connector part is received within an opening of the end cap assembly, the first and second surfaces are placed in confronting relationship to prevent separation of the first and second connector parts as an incident of the first connector part moving relative to the second connector part from a position fully separated from the second connector part in a substantially straight path that is transverse to the length of the lamp body. The snap-fit connection does not utilize exposed pins to mechanically secure the lamp ends to the support and is effected by a linear motion rather than an insert and rotate technique. The first end cap assembly includes at least a first connector board. The connector board comprise generally L-shaped pins housed within the end cap assembly, each having a first portion extending in a direction generally parallel to the length of the body and a second portion extending in a direction transverse to the length of the body and towards the second connector part when said first connector part is moved towards the second the second connector part and into the engaged position. The conductive components on each of the first and second connector parts electrically connect to each other to form an electrical path between the illumination source and an external power supply as an incident of the connector parts being moved into the snap-fit engaged configuration.

The above-mentioned snap-fit connector system addresses some of the problems associated with the use of conventional tombstone type lamp holders for securing LED tube lamps to lighting fixtures. However, it maintains the LED tube lamp in an operating state without providing a means for ground protecting the LED tube heat sink or the internal electrical components of the lamp, thus creating safety and reliability issues for the lamp installation. There is a need for a connector system designed for the unique needs of LED lamp technology that alleviates all safety concerns and provides a safe, reliable and convenient solution that will allow the benefits of LED lamp technology to be fully realized and can be implemented in a cost-effective manner.

BRIEF DESCRIPTION OF THE DRAWINGS

FIG. 1 is a fragmentary, perspective view of an elongate tubular lighting assembly, and showing cooperating connector parts at one end of a body on or within which there is a source of illumination;

FIG. 2 is a view as in FIG. 1 with the connector parts fully separated from each other;

FIG. 3 is a view as in FIG. 2 showing cooperating connector parts at the opposite end of the body;

5

FIG. 4 is an enlarged, end view of the connector parts shown in the relationship of FIG. 2;

FIG. 5 is a view as in FIG. 4 with the connector parts joined in an assembled configuration;

FIG. 6 is an exploded, perspective view of an end cap assembly consisting of the connector parts in FIG. 2 and a connector board for the source of illumination;

FIG. 7 is a view as in FIG. 6 with the parts assembled;

FIG. 8a is a perspective view of tubular lighting assembly, and showing cooperating connector parts at each end of the body configured to connect to an external power source at each end of the body;

FIG. 8b is a perspective view of tubular lighting assembly, and showing cooperating connector parts at each end of the body, with one set of cooperating connector parts configured to connect to an external power source;

FIG. 9 is a perspective view of tubular lighting assembly, and showing cooperating connector parts at one end of the body, configured to connect to an external power source and a connector sleeve at the other end of the body;

FIG. 10 is a fragmentary, perspective view of an elongate tubular lighting assembly, and showing cooperating connector parts at one end of a body and including cooperating ground protection components;

FIG. 11 is a fragmentary, perspective view of an elongate tubular lighting assembly, and showing cooperating connector parts at one end of a body and including alternative cooperating ground protection components;

FIG. 12 is a fragmentary, perspective view of an elongate tubular lighting assembly, and showing cooperating connector parts at one end of a body and including alternative cooperating ground protection components;

FIG. 13 is a fragmentary, perspective view of a multi-sided elongate tubular lighting assembly, and showing cooperating connector parts at one end of a body and including alternative cooperating ground protection components;

FIG. 14 is a fragmentary, perspective view of an elongate tubular lighting assembly, and showing cooperating connector parts comprising a connector sleeve at a no power end of a body and including cooperating ground protection components; and

FIG. 15 is a fragmentary, perspective view of an elongate tubular lighting assembly, and showing cooperating connector parts comprising a connector sleeve at a no power end of a body and including alternative cooperating ground protection components.

FIG. 16 is a fragmentary, perspective view of another embodiment of a multi-sided elongate tubular lighting assembly, and showing cooperating connector parts at one end of a body and including alternative cooperating ground protection components;

FIG. 17 is a fragmentary, perspective view of another embodiment of a generally cylindrical elongate tubular lighting assembly, and showing cooperating connector parts at one end of a body and including alternative cooperating ground protection components;

FIG. 18 is a perspective view of the cooperating connector parts in FIG. 17 in an assembled configuration;

FIG. 19a is an end view of the cooperating connector parts in FIG. 17 in a partially assembled configuration;

FIG. 19b is an end view of the cooperating connector parts in FIG. 17 in a fully assembled configuration;

FIG. 20a is an end view of one of the connector parts in FIG. 17;

FIG. 20b is a side view of the connector part in FIG. 20a;

FIG. 21a is a side view of the other connector part in FIG. 17; and

6

FIG. 21b is an end view of the connector part in FIG. 21a.

FIG. 22 is perspective view of a linear lighting assembly, and showing cooperating connector parts at each end of the body, with one set of cooperating connector parts configured to connect to an external power source with isolated ground protection.

DESCRIPTION OF THE PREFERRED EMBODIMENTS

For the purposes of promoting an understanding of the principles of the invention, reference will now be made to the embodiments illustrated in the drawings and specific language will be used to describe the same. It will nevertheless be understood that no limitation of the scope of the invention is thereby intended. Any such alterations and further modifications in the illustrated devices, and such further applications of the principles of the invention as illustrated herein are contemplated as would normally occur to one skilled in the art to which the invention relates.

There is a need for an improved lamp holder and connector system that address all safety issues and provides a grounded LED lighting system in the linear tube format that is widely deployed throughout the lighting industry. As used herein, the terms “LED tube lamp” and “linear LED lamp” and similar variants are used interchangeably to describe LED lamps having at least one LED board mounted on an externally exposed heat sink having a narrow and elongated overall profile and with optional elongated optical lens, and designed for removable mounting to a variety of lighting fixture housings. While the overall form factor of such lamps is ordinarily generally similar to that of conventional fluorescent tube lamps, the use of these terms is not intended to limit the scope of the disclosed or claimed subject matter to lamps having any particular lateral cross-sectional shape or to require a fully enclosed outer tubular structure.

FIGS. 1 to 7 illustrate an available snap-fit connector system for linear LED tube lighting. The lamp comprises an elongate tubular body portion 10 including a metallic heat sink 12 extending throughout a generally upward facing portion of the circumference of the tubular body, and a transparent or translucent lens portion 14 extending throughout a generally downward facing portion of the circumference of the tubular body. The heat sink is preferably formed of an aluminum alloy, although other thermally conductive materials may be used. At least one LED emitter panel comprising a printed circuit board mounting a series of LEDs is mounted to the heat sink internal to the tubular body. Heat generated by the LEDs conducts through the emitter panel to the heat sink. The heat sink of the illustrated lamp is multi-sided with a generally triangular cross-sectional geometry in a plane perpendicular to the length of the lamp body, providing two mounting surfaces for supporting multiple LED emitter panels in a V-orientation. End cap assemblies disposed at the opposite lamp ends have a corresponding triangular cross-section in a plane perpendicular to the length of the body.

The available system mechanically secures the LED tube lamp to a support and electrically connects it to an external power supply, but leaves the lamp heat sink and internal electronic components in an ungrounded state. As can be seen in FIGS. 1-3, a first connector 100 at the first end 20 of the body 10 is made up of a first connector part 110 and a second connector part 120. A second connector 400 is provided at the second end 30 of the body 10 and is made up of a third connector part 410 and a fourth connector part 420. The body of the connector parts are formed of plastic

or other non-conductive material and are preferably manufactured using conventional injection molding techniques.

The first and second connectors **100**, **400** are configured to maintain the body **10** in an operative state on a support **50** that may be in the form of a reflector, or otherwise configured. The first connector part **110** is part of a first end cap assembly **112** that is provided at the first body end **20**. The second connector part **120** is provided on the support/reflector **50**. The third connector part **410** is provided at the second end **30** of the body **10**, with the fourth connector part **420** provided on the support/reflector **50**. The body includes at least one LED emitter panel providing a source of illumination, which is electrically connected to a power supply through the first connector **100**.

As shown in FIG. **4**, second connector part **120** has oppositely opening slots **129**, **129'**. The slots cooperate with the reflector tabs **52**, **54** as illustrated in FIG. **1**. That is, the tabs **52**, **54** are formed so that they can slide through the slots **129**, **129'** whereby the second connector part **120** and support/reflector **50** can be press connected starting with these parts fully separated from each other. A simple sliding movement lengthwise of the body **10** will fully seat the tabs **52**, **54** that become frictionally held in the slots **129**, **129'**. The fourth connector part **420** also includes slots that provide for releasable connection to tabs of the support/reflector **50** in substantially the same way.

As shown in FIGS. **1**, **6** and **7**, first end cap assembly **112** which forms the first connector part **110** consists of a first, cup-shaped receptacle **119** into which the first end of the body extends. The first end cap assembly **112** is shaped to accommodate a multi-sided heat sink having a generally V-shaped cross-section for supporting multiple LED emitter boards, and an internal driver board. Other end cap and heat sink configurations are possible.

In FIG. **4**, the first connector part **110** is shown in a position fully separated from the second connector part **120**. In FIG. **5**, the first connector part **110** is shown moved relative to the second connector part **120** from the fully separated position in a substantially straight path, as indicated by the upward pointing arrow, transverse to the length of the body **10**, into the engaged upward facing wall **114** bounded by an edge. Second connector part **120** has a first bendable part **122**. The second connector part **120** is configured so that the first bendable part **122** is engaged by the edge of the opening **116** and progressively cammed from a holding position, as shown in solid lines in FIGS. **4** and **5**, towards an assembly position, as shown in dotted lines in each of FIG. **4** and FIG. **5**, as the lamp end **20** and first connector part **110** is moved upward to and into the engaged position. The first bendable part **122** moves from the assembly position back towards the holding position with the first part realizing the engaged position.

The first connector part **110** has a wall **114** through which the opening **116** is formed. A first surface **117** is a portion of the inner surface of this wall **114**. A second surface **124** is defined by a boss **126** on the bendable part **122**. The wall **114** has a third surface **118** on its opposite surface that faces towards a fourth surface **128** on the second connector part **120**. The wall **114** resides captively between the second and fourth surfaces **124**, **128** with the first connector part **110** in the engaged position to maintain this snap-fit connection.

As can be seen in FIG. **2**, first bendable part **122** is joined to the leading end **127** of the second connector part **120** through a live hinge **125**. The second connector part **120** has an actuator **121**, in this embodiment on the first bendable part **122** remote from the hinge **125**, that can be pressed in the direction of the horizontal arrow in FIG. **4** with the first

connector part **110** in the engaged position, thereby to move the first bendable part **122** towards its assembly position, as shown in dotted lines in FIGS. **4** and **5**, to allow the surface **124** to pass through the opening **116** so that first connector part **110** can be separated from the second connector part **120**. The second connector part **120** has a second bendable part **122'** on an opposite side that is configured the same as the first bendable part **120** and cooperates with the edge of opening **116** in the same way that the first bendable part **120** cooperates with the edge in moving between corresponding holding and assembly positions. An actuator **121'** is situated so that the installer can grip and squeeze the actuators **121**, **121'**, as between two fingers, towards each other, thereby changing both bendable parts **122**, **122'** from their holding positions into their assembly positions.

The second connector **400** has third and fourth connector parts **410**, **420** that are respectively structurally the same as the first and second connector parts and interact with each other mechanically at the second end **30** of the body **10** in the same way that the first and second connector parts **110**, **120** interact with each other at the first end **20** of the body. The first and second connectors **100**, **400** are configured to maintain the body **10** in an operative state on a support **50** that may be in the form of a reflector, or otherwise configured.

In the embodiment shown, at least the first end **20** of the LED tube lamp is adapted to receive power from an external power supply. As shown in FIGS. **6** and **7**, the receptacle **119** may receive an end connector board **60** having L-shaped electrical connector terminals **62**, **64** thereon that cooperate with connector assemblies **72**, **74** having wires that extend through second connector part **120** to establish electrical connection between the board **60** and the power supply. The connector terminals **62**, **64** may be mechanically and electrically connected to the board **60**, and the board includes traces to form electrical paths from the connector terminals **62**, **64** to terminals such as terminals **66**. The terminals **66** cooperate with pins extending from LED emitter boards, driver circuit boards or other electrical components to provide power to such components. Alternatively, the connector terminals **62**, **64** may electrically connect to the LED emitter boards and/or other electrical components of the LED lamp system via one or more wires. The L-shaped electrical connector terminals **62**, **64** of connector board **60** each have a first portion extending in direction generally parallel to the length of the body and a second portion extending in a direction transverse to the length of the body and towards the second connector part **120**. When said first connector part **110** is moved towards the second the second connector part and into the engaged position, the first and second connector parts **110**, **120** can be mechanically snap-connected, and connector assemblies **72**, **74** are also press fit into electrical connection with the connector terminals **62**, **64** as an incident of the first connector part **110** moving from its fully separated position into its engaged position.

FIG. **8a** illustrates an installation using a snap-fit connector system of this type in which power is supplied to both ends of the linear LED tube lamp body **10**. In FIG. **8a**, the connector is shown for a linear LED tube lamp of a generally circular cross-section. Snap-fit connectors **100** and **400** are provided at opposite ends of the lamp comprising first and second connector parts **110**, **120** and third and fourth connector parts **410**, **420** respectively. The depicted lamp is designed to be connected to and receive power from an external power supply at both lamp ends, as shown in FIG. **8a**. The connector system components at each end of the lamp thus includes both the mechanical and electrical con-

necter components described above. Some LED lamps are configured to connect to the external power supply at only one end. As illustrated in FIG. 8*b*, for a lamp of this type shown as lamp 11, the second connector 400 may include only the components needed to mechanically connect third connector part 410 of second end cap assembly to fourth connector part 420. In other words, the second end cap assembly and the fourth connector part 420 need not include electrical connector terminals and may be provided without a means for connecting to the power supply.

The connector systems described thus far for powering the internal components of the lamp leave the internal components, and the externally exposed lamp heat sink, in an ungrounded condition. There is a risk of damaging the internal components in the event of a power surge, and the heat sink presents a potential electric shock risk and/or fire hazard if applied power leaks to the heat sink as a result of a short circuit condition.

FIG. 9 illustrates an alternative, improved connector system adapted for single end power linear LED tube lamps in which only one end of the lamp is configured to connect to and receive power from an external power supply. In this system, the end 30 of the LED tube lamp 12 shown, is adapted to receive power through connector assemblies 72 and 74. It is secured to support 50 by means of connector 400 consisting of third connector part 410 having an opening in its sidewall and fourth connector part 420 having moveable components for making a snap-fit connection with the sidewall, as described above with reference to the FIGS. 1 to 7 and 8*a*. The opposite end 35 of lamp 12 includes an end cap assembly 510 of cylindrical shape having a receptacle into which the second end of lamp 12 inserts. The end cap assembly 510 need not include an opening in its side wall, as it does not engage a male snap-fit connector part of the type depicted as fourth connector part 420 for securing the first lamp end 30.

The system further includes plastic connector sleeve 520, which is adapted to mount to support 50. A base portion 522 of connector sleeve 520 includes slots 530 on opposite sides thereof into which tabs 52, 54 of support 50 slide so that connector sleeve 520 can be secured to support 50. The base portion 522 extends toward sleeve portion 524 comprising a continuous sidewall 526 and end wall 528, which form a receptacle having an open end facing towards the opposite fourth connector part 420 and sized to receive the second end cap assembly 510 of the LED lamp. The sleeve portion 524 is preferably of a cross-sectional shape that conforms to the cross-sectional shape of end cap assembly 510, which is circular in the illustrated embodiment. Connector sleeves comprising a sleeve portion of other cross-sectional geometries, such as generally triangular, square or rectangular, are also contemplated for use with other lamps having corresponding end cap cross-sectional geometries. In one preferred form, the sleeve forms a receptacle of a generally triangular cross-section for receiving a generally triangular end cap assembly of a lamp comprising a multi-sided heat sink mounting multiple LED emitter boards such as the lamp illustrated in FIGS. 1 to 3.

FIG. 9 shows the fourth connector part 420 of connector 400 and connector sleeve 520 mounted to support 50 at opposite ends of a light fixture. LED tube lamp 12 may be installed in the fixture by inserting the end cap assembly 510 at the end 35 linearly along the length of the lamp body in the direction of the horizontal arrow into the receptacle of connector sleeve 520. The connector sleeve is preferably sized so that end cap assembly 510 is easily guided into the receptacle, where it is supported in the vertical direction yet

adjustable in the horizontal direction. Next, the third connector part 410 of the end cap assembly at the opposite end 30 is adjusted so that its opening is aligned with the fourth connector part 420. In the case of a cylindrical lamp, this may also require rotating the lamp about its longitudinal axis to radially aligning the female opening of third connector part with the male portion of fourth connector part at the power end. The third connector part is then moved upward in the direction of the vertical arrow towards fourth connector part 420 so as to guide the fourth connector part 420 into snap-fit connection with third connector part 410. Securing the snap-fit connection at the power end 30 of the lamp locks the lamp at its proper rotational orientation and prevents the lamp from backing out linearly from connector sleeve 520, and the lamp is thus securely maintained in an operational state. To remove an installed lamp, the snap-fit connection may be released using the actuators as previously described, which allows withdrawing the end cap assembly 510 at end 35 from the receptacle of connector sleeve 520.

This connector system offers potential advantages compared to the alternative approach of deploying a power enabled snap-fit connector at the power end of the lamp and modified no power snap-fit connector at the opposite no power end. It eliminates the need to manufacture and distribute alternative versions of the snap-fit connector for power and no power applications. It also facilitates simplification of LED tube lamp design, as the no power end 35 requires only a simple end cap without any modifications to accommodate a snap-fit connection system or external bi-pin terminals adapted for conventional tombstone lamp holders. The connector sleeve 520 is easily manufactured and contains no moving parts.

Moreover, the sleeve 520 provides convenience to the lamp installer and a more efficient installation methodology. With standard linear LED tube lamps typically ranging from 2 to 8 feet in length, it is cumbersome to properly align the cooperating components into the proper engaged position while handling a portion of the lamp that is significantly displaced from the lamp end being installed. Thus, lamp installation typically requires the installer to grasp a first end of the lamp and position it into engagement with its corresponding lamp holder, whether a snap-fit connector or rotating tombstone lamp holder, and then move to a position proximate the opposite end of the lamp to manipulate the opposite end into engagement with its lamp holder. Using the connector sleeve 520, however, both ends of the lamp may be installed by manipulating the lamp from the power end. While grasping the lamp near the power end 30, the installer may guide the opposite no power end 35 into the receptacle opening of connector sleeve 520. This requires only minimal dexterity and skill compared to the more precise positioning and controlled movements needed to guide the components of the snap-fit or tombstone type connector system together. After the no power end is seated in the receptacle of the connector sleeve, the installer may adjust the linear and angular position of third connector part 410 at the power end 30 as necessary to align its connector opening with fourth connector part 420 while the opposite end 35 remains seated in the connector sleeve. While remaining at the same location, the installer then moves the lamp end 30 directly upward from the separated position and into snap-fit engagement with fourth connector part 420 pre-mounted on support 50. Potentially significant time and associated labor savings may be achieved with this system and installation method, especially in commercial environments requiring installation of hundreds or potentially thousands of LED tube lamps.

11

With connector systems suitable to mechanically and electrically connect linear LED tube lamps to a support having thus been described, the following discloses improved connector systems capable of providing ground protection to the lamp heat sink and/or internal electronic components. FIG. 10 is directed to a snap-fit connector system for a linear LED tube lamp that includes an integrated grounding system for providing ground protection to the LED tube heat sink. LED tube lamp 250 comprises an elongate tubular body portion including a metallic heat sink 254 extending throughout a generally upward facing portion of the circumference of the tubular body, and a transparent or translucent lens portion 252 extending throughout a generally downward facing portion of the circumference of the tubular body. The heat sink is preferably formed of an aluminum alloy, although other thermally conductive materials may be used. At least one LED emitter panel 270 comprising a printed circuit board mounting a series of LEDs is mounted to the heat sink internal to the tubular body. Heat generated by the LEDs conducts through the emitter panel to the heat sink. The heat sink may include fins 255 extending along its length to increase the effective surface area for transfer of heat to the atmosphere. The LED lamp 250 may include an internal ballast or driver module or may alternatively utilize an external ballast associated with the lighting fixture. Heat sink 254 has a generally semi-circular cross-section in a plane perpendicular to the length of the lamp, with support wall 259 extending across the internal region thereof to provide a mounting surface for LED emitter panel 270. Other heat sink geometries are also contemplated, including, for example, a configuration such as the one illustrated in FIG. 13 comprising multiple support walls arranged in a generally V-shape and lying in intersecting planes for supporting multiple LED emitter panels arranged to distribute light over a wide area.

With further reference to FIG. 10, LED lamp 250 is mounted at its first end to a support 50 of a lighting fixture by means of snap-fit connector system 200 comprising first connector part 210 and second connector part 220. Several aspects of the components of the snap-fit connector system of FIG. 10 for securely connecting LED lamp 250 to support 50 are substantially the same structurally as described above with reference to the snap-fit system illustrated in FIGS. 1-7. Thus, second connector part 220 is provided on the support/reflector 50. The support 50 may be a reflector portion of an existing ceiling lighting fixture of the type conventionally used for linear fluorescent tube lighting. The connector system of the invention may be utilized in other types of lighting fixtures secured to an overhead ceiling grid or to another structure. The LED emitter panel 270 providing a source of illumination is electrically connected to a power supply through the connector system 200. The second connector part 220 can be press connected to the support 50 by means of oppositely opening slots that cooperate with the support tabs 52, 54. Of course other releasable, and potentially permanent, connections are contemplated.

The first connector part 210 is part of a first end cap assembly 214 that is provided at the first end of LED lamp 250. The first end cap assembly 214 is formed of plastic or other non-conducting material and comprises cylindrical side wall 212 extending from circular end wall 230. First end cap assembly 214 forms a cup-shaped receptacle into which the first end of the body of LED lamp 250 extends. An opening 216 is formed in side wall 212 to receive a portion of second connector part 220.

The second connector part 220 has a pair of bendable parts 222 on opposite sides thereof, each operable through

12

hinge 225, which are engaged by the edge of the opening 116 and progressively cammed from a holding position towards an assembly position as the first connector part 210 is moved up to and into the engaged position. The first bendable parts 222 move from the assembly position back towards the holding position with the first part realizing the engaged position. The wall 214 resides captively between surfaces of the first connector part 210 in the engaged position to maintain this snap-fit connection. A pair of actuators 221 on opposite sides of second connector part 220 can be pressed to move the first bendable parts 222 towards its assembly position, in the same manner shown in dotted lines in FIGS. 4 and 5, to allow them to pass through the opening 216 so that first connector part 210 can be separated from the second connector part 220.

As FIG. 10 illustrates, the receptacle of end cap assembly 214 may receive an end connector board 260 having L-shaped electrical connector components 262, 264 thereon that cooperate with connector assemblies 72, 74 having wires that extend into the second connector part 220 and connect to a power supply. The connector components 262, 264 may connect to LED emitter board 270 by means of wires 266 and may similarly provide power to other internal components of LED tube lamp 250. In one aspect, wires 266 connect to an internally mounted driver module to provide AC line voltage which the driver module converts to DC voltage supplied to the LED emitter board and optionally other internal componentry. Although the embodiment illustrated in FIG. 10 utilizes internal wire connections, the end connector board 260 may alternatively be in the form of a printed circuit board (PCB) connector containing male or female electrical terminals for connecting to corresponding terminals associated with LED emitter board 270, a driver circuit or other internal components of the lamp to provide a no-wire design. In both approaches, connector components 262, 264 provide an electrical path over which electrical power from a power supply is provided to the LED emitter board 270 and optionally other internal components. The L-shaped electrical connector components 262, 264 on the connector board 260 each have a first portion extending in direction generally parallel to the length of the body and a second engagement portion extending in a direction traverse to the length of the body and towards the second connector part 220 when said first connector part 210 is moved towards the second the second connector part and into the engaged position.

Heat sink 254 has a planar end face 258 at a first end thereof defining a pair of apertures 257. Connector end board 260 includes a pair of corresponding apertures 253 aligned with heat sink apertures 257. End wall 230 of first end cap assembly 214 defines corresponding aligned apertures 236. The end cap assembly 214 and end connector board 260 may be secured to heat sink 254 at the first end of LED tube lamp 250 with a pair of metallic fasteners 234 extending through the corresponding apertures and into the end face 258 of the heat sink. When assembled, the end board 260 and end portions of the heat sink and translucent lens portion 252 reside within the receptacle of end cap assembly 214.

Connector system 200 of this first embodiment of the invention comprises additional components that provide for grounding heat sink 254 as an incident of the snap-fit mechanical connectivity described above. In particular, second connector part 220 includes an integrated metal ground strap 238a mounted to a side surface thereof. The ground strap 238a extends from a base portion of second connector part 220 proximate the support 50 towards the distal leading

end of second connector part 220 as shown. Ground strap 238a is mounted on the side surface of second connector part 220 that opposes end wall 230 of first end cap assembly 214 when the first connector part 210 and second connector part 220 are in the assembled configuration. Those skilled in the art will recognize a number of available techniques for mounting ground strap 238a to second connector part 220, including the use of mechanical fasteners, adhesives, mounting tabs or slots formed integral with second connector part 220, or using in laid injection molding techniques or any other available means. Ground strap 238a is connected at its proximal end to ground wire 76 via a connection internal to second connector part 220 (not shown).

First end cap assembly 214 is shown in FIG. 10 with a portion cutaway to better illustrate ground plate 232, which is mounted along the inner surface of end wall 230 of first end cap assembly. Ground plate 232 is of a conductive material, and defines apertures aligned with apertures 236 of end wall 230 for receiving the fasteners 234. The ground plate 232 may be mounted internal to first end cap assembly 214 by any available means, including by mechanical fasteners, adhesives, mounting tabs or slots formed integral with first end cap assembly, by means of in-laid injection molding techniques, or any other available means.

With the first end cap assembly 214 assembled to heat sink 254 as described, ground plate 232 is in electrical contact with the heat sink via the fasteners 234. At least a portion of ground plate 232 is of a thickness dimension such that when second connector 220 inserts through the opening 216 into the assembled position within first connector 210, a portion of the exposed conductive surface of ground plate 232 engages an opposing conductive surface of ground strap 238a.

Support 50 is grounded through mechanical connections to the ceiling infrastructure and/or via a connection to an isolated ground wire also providing grounding back to the dedicated ground bus of in input electrical power panel. Ground wire 76 may be connected to the support or to the ceiling infrastructure, or may be wired to a dedicated ground bus, to provide a grounding path for the snap-fit connector system and LED lamp. Thus, heat sink 254 is ground protected by the grounding path provided by the fasteners 234, ground plate 232, ground strap 238a and ground wire 76. This snap-fit connector system with integrated grounding electrically grounds the lamp heat sink to the externally grounded lighting fixture or other grounded system as an incident of the first connector 210 and second connector 220 being snap-fit into the fully engaged configuration, thereby eliminating the potentially hazardous condition associated with an ungrounded heat sink.

Ground strap 238a of the invention may be provided in various shapes, sizes and configurations adapted to establish the desired grounding connection in a wide range of available LED lamp end cap assemblies. In one aspect, ground strap 238a may extend further in the horizontal and/or vertical direction than depicted in FIG. 10 so as to directly engage the support 50 when the second connector part 220 is mounted to the support. In this alternative, the first connector part may form a direct mechanical ground connection with the support 50 without the use of ground wire 76.

Ground plate 232 may also be provided in various different forms other than the circular plate illustrated in the embodiment of FIG. 10. For example, ground plate 232 may be provided as a thin conductive clip mounted to the internal surface of end wall 230 and extending generally parallel and opposite ground strap 238a of second connector part 220.

The plate may include a portion that protrudes away from end wall 230 and towards the ground strap 238a for contacting ground strap 238a of second connector part 220. It will be appreciated from the teachings herein, that various shapes, sizes and geometries of ground strap 238a and ground plate 232 can be utilized within the scope of the invention so long as these two components are adapted to come into physical contact with each other when the first connector part 210 and second connector part 220 of connector system 200 are moved into an engaged configuration.

FIG. 11 is directed to another embodiment of a ground protecting connector system to further illustrate possible ways of implementing the principles of the invention. The connector system of this embodiment is essentially the same in overall design and functionality as grounded connector system 200 of FIG. 10 except for the specific configuration of the ground strap. The structure and operation of like components is therefore not repeated. In particular, the ground strap 238b of this embodiment is secured at its proximal end to second connector part 220 and has an outwardly protruding profile. It includes a first ramp surface 238b' extending away from the side surface of second connector part 220, a mid-portion 238b'' extending generally parallel to the side surface, and a terminal end portion 238b''' angled back slightly toward the side surface. When the first and second connector parts are in an engaged configuration, mid-portion 238b'' engages the inner surface of ground plate 232 to complete a grounding path for the system. Ground strap 238b is preferably formed of a thin piece of spring steel having a high yield strength that allows it to be deformed and return to its original shape despite significant deflection. In the engaged configuration, ground plate 232 slightly compresses ground strap 238b from its relaxed shape such that its mid-portion 238b'' is displaced towards the side surface of first connector part 220. The resulting spring force biases the mid-portion in the direction of and against the ground plate 232 to maintain secure contact between the mid-portion and the plate.

Another embodiment of a grounded connector system in accordance with the principals of the invention can be seen in FIG. 12. The connector system of this embodiment is essentially the same in overall design and functionality as grounded connector system 200 of FIG. 10 except for the specific configuration of the ground strap. The structure and operation of like components is therefore not repeated. In particular, the ground strap 238c of this embodiment is provided as a thin wire mesh integrated into the side wall of second connector part 220 by utilizing an in-laid injection molding process. An outer surface of the wire mesh is exposed such that it engages and forms an electrical grounding path with a portion of the inner surface of end plate 232 of first connector part 210 when the connector components are in the engaged configuration. This embodiment may provide manufacturing advantages and results in the second connector part 220 having a thinner profile with no protruding components susceptible to being bent or damaged.

FIG. 13 is directed to another embodiment of the grounding system of the invention that can ground protect both the LED tube lamp heat sink and its internal LED emitter board and other internal electronic components. This embodiment is illustrated by reference to a LED tube lamp 350, which includes multi-sided heat sink 354 with a pair of support walls 359 having a generally V-orientation for supporting multiple LED emitter boards 370 facing different directions. Other components such as an internal driver circuit may also be mounted to the heat sink. The end connector and grounding system of this embodiment may also be adapted to other

LED tube lamp forms, including those having a generally circular cross section and a single LED emitter board mounting surface as depicted in FIGS. 10 to 13.

The connector system 300 of the embodiment of FIG. 13 includes first connector part 310 formed as part of first end cap assembly 314 and second connector part 320 secured to support 50. The first end cap assembly 314 consists of a first, cup-shaped receptacle into which the first end of the LED tube lamp body extends. The first end cap assembly 314 is shaped to accommodate the multi-sided heat sink 354. It comprises side walls 312 extending perpendicular from end wall 330 and forming a receptacle having a generally triangular cross-section. Similar to the embodiments of FIGS. 10-12, first end cap assembly 314 includes an internal ground plate 332, which is shown in the cutaway view of FIG. 13. The second connector part 320 is of similar design as the connector part 220 described above in connection with the embodiment of FIG. 10. It is adapted to extend through an opening in the upper facing side wall of first end cap assembly 314 and form a snap-fit connection to the first connector part by the action of bendable members 322 and live hinges 325 on opposite sides thereof in essentially the same manner described for other embodiments. Second connector part 320 further includes ground strap 338a on one side thereof for engaging ground plate 332 of first connector part 310 when the two connector parts are in the engaged configuration. The ground plate 332 is in electrical contact with heat sink 354 through metallic fasteners 334, which extend through the aligned apertures of end wall 330, ground plate 332 and end connector board 360 and into corresponding mounting apertures 357 in the end face of the heat sink. Ground strap 338a is secured to ground wire 76. Thus, in essentially the same manner described above in reference to the embodiment of FIG. 10, the ground plate 332, fasteners 334, ground strap 338a and ground wire 76 provide a means to ground protect heat sink 354 when LED tube lamp 350 is installed in the operating state to the support using end connector 300.

The end connector board 360 of this embodiment is a PCB connector board having L-shaped electrical connector components 362, 364 thereon that insert into corresponding spaced receptacles in second connector part 320 and cooperate with connector assemblies 72, 74 having wires that extend through the second connector part 320 to establish electrical connection between the board 360 and the power supply. The connector components 362, 364 may be mechanically and electrically connected to the board 360, and the board includes traces to provide electrical paths from the connector components to terminals such as terminals 365. The terminals 365 cooperate with pins 372 extending from LED emitter boards, driver circuit boards or other electrical component to provide power to such components. Thus an electrical path is established between the power supply and the internal componentry of the LED tube lamp 350 when the first and second connector parts of connector 300 are in the engaged configuration.

In the embodiment shown, end connector board 360 also includes L-shaped electrical ground pin 366. Second connector part 320 has a female receptacle 342 adapted to receive the vertically extending portion of the ground pin 366 when the first and second connector parts 310, 320 are in the assembled configuration. Receptacle 342 includes an internal connector component (not shown) that forms an electrical path with ground wire 76, or with a separate ground wire, such that ground pin 366 may function to provide additional ground protection for LED tube lamp 350. In a preferred aspect, end connector board 360 includes

traces electrically connecting ground pin 366 to one of the terminals 365 to provide an isolated grounding path for the internal components of the lamp 350 connected to the terminals 365. In another aspect, ground pin 366 may also be electrically connected to wire 367 and its loop connector 368. One of the fasteners 334 may extend through the loop connector 368 to form a ground connection between heat sink 354 and ground pin 366. This may provide for redundant grounding of the heat sink, or may render the ground strap 338a and ground plate 332 unnecessary. Alternatively, ground pin 366 may be electrically connected to the edge of one or more of the screw apertures via internal traces of end connector board 360 and the wire 367 eliminated. The embodiment of FIG. 13 thus provides multiple options for providing ground fault protection to internal componentry and the heat sink. In a preferred form, ground strap 338a and ground plate 332 provide a grounding path for heat sink 354, and ground pin 366 functions to ground the internal componentry of the LED tube lamp.

The ground protected LED lamp connector embodiments described previously provide a ground path for the lamp heat sink and/or internal components at an end of the lamp adapted to receive power from an external power supply. It will be recognized that any of the above embodiments may be modified to provide a ground protected snap-fit connector system for the no power end of a single end powered lamp. For example, end connector board 260 of the embodiments of FIGS. 10-12, and associated connectors and wires, may be eliminated at the no power end with the connector 200 still functioning to provide a ground path for the lamp heat sink in the same manner described above. Connector components 72, 74 are also unnecessary at the no power lamp end. Similarly, end connector board 360 may be eliminated to adapt connector 300 of FIG. 13 for a lamp end that does not receive external power. Alternatively, end connector board 360 may be provided without L-shaped connector components 362, 364, but with ground pin 366 to provide isolated ground protection to the lamp internal components in the manner described. The system is thus highly adaptable to a variety of LED lamp designs and powering options, as may be flexibly implemented to suit the needs of each individual lighting installation.

FIG. 14 is directed to an alternative connector system adapted to secure the no power end of a linear LED tube lamp to a light fixture, as well as to provide ground protection to the lamp heat sink. Connector sleeve 600, which is preferably an injection molded plastic component, is of a form similar to connector sleeve 520 discussed above with reference to FIG. 9. A base portion 630 of connector sleeve 600 includes slots 632 on opposite sides thereof into which tabs 52, 54 of support 50 slide to secure connector sleeve 600 to support 50. The base portion 630 extends toward sleeve portion 624 comprising cylindrical sidewall 612 and end wall 610, which form a cylindrical receptacle 614 sized to receive cylindrical end cap assembly 660 of the no power end of LED lamp 650. Connector sleeve 600 includes ground plate 620 comprising a conductive material and mounted adjacent the inner surface of end wall 610. Ground plate 620 is electrically connected to ground wire 680. The sleeve portion 624 is preferably of a cross-sectional shape selected to match the cross-sectional shape of plastic end cap assembly 660, which is cylindrical in the illustrated embodiment. Connector sleeves comprising a sleeve portion of other cross-sectional geometries, such as generally triangular, square or rectangular, are also contemplated for use with other lamp designs.

LED tube lamp **650** comprises heat sink **654** of a semi-circular cross-section and having a support surface on which LED emitter board **670** is mounted. Translucent lens cover **652** is attached to heat sink **654**. End cap assembly **660** forms a cylindrical receptacle into which and end portion of the heat sink and lens cover inserts. End cap assembly **660** is non-conductive and includes an annular lip **664** circumscribing a recessed mid-portion of the outer surface of the end wall thereof. Ground plate **666** is disposed in the recessed mid-portion and retained by lip **664**. Ground plate **666** is of a conductive material and includes central boss **668** protruding outwardly of its outer surface. End cap assembly **660** is secured to the lamp by means of metallic fasteners **657** extending through apertures **661** of the end wall and ground plate and into mounting apertures **655** and **657** of end face **658** of the heat sink. Ground plate **666** is thus in electrical contact with heat sink **654** through fasteners **657**.

In the same manner described above with reference to FIG. **9**, the no power end LED tube lamp **650** of FIG. **14** inserts linearly into receptacle opening **614** of connector sleeve **600**. The opposite power input end of lamp **650** is preferably configured with the snap-fit end cap assembly of the type discussed herein to provide for mechanical and electrical connection to a male snap-fit connector mounted to support **50** upon moving the power end upward towards and into engagement with the male snap-fit connector part. With lamp **650** secured to support **50** in its installed configuration, boss **668** is forced into abutting engagement with the exposed conductive surface of ground plate **620**. This engagement completes a grounding path between heat sink **654** and ground wire **680**, which may be grounded to the light fixture or to an external isolated ground connection to provide ground protection to the heat sink.

Ground plate **666** may be provided in various shapes, sizes and configurations adapted to establish the desired grounding connection in a wide range of available LED lamp end cap assemblies. It may be provided, for example, as one or more thin conductive straps mounted to the external surface of the end wall of end cap assembly **660** or integrated into the end wall using in-laid molding techniques. Ground plate **620** may also take on other forms besides the circular plate illustrated in the embodiment of FIG. **14**. For example, ground plate **620** may be provided as a thin conductive clip mounted to the internal surface of end wall **610** and extending generally parallel and opposite ground plate of the end cap assembly **660**. Instead of boss **668** provided on ground plate **666**, a boss may be provided on the ground plate **620** protruding into the receptacle of connector sleeve **600** to provide for contact with a planar form of ground plate **666**. It will be appreciated from the teachings herein, that various shapes, sizes and geometries of ground strap ground plate **666** and ground plate **620** are within the scope of the invention so long as these two components are adapted to come into physical contact with each other when the end cap assembly **660** is seated in connector sleeve **600** and the opposite lamp end secured to the support **50** by a snap-fit connector system of the type described herein.

As illustrated in FIG. **15**, LED tube lamp **650** may be provided with an alternative end cap assembly **690** adapted for use with the same connector sleeve **600** just described. The end cap assembly in this embodiment comprises planar end wall **694** forming on outer end surface of the assembly and cylindrical side wall **692** which extends from the end wall. Ground plate **696** is mounted internal of end wall **694** as shown. Boss **698** of ground plate **696** protrudes through a central opening of end wall **694** as shown. Fasteners **667**

extend through apertures **663** in the end wall and ground plate and into apertures **655** and **657** of end face **658** of the heat sink to secure end cap assembly **690** to the lamp. With end cap assembly **690** inserted into connector sleeve **600** to the assembled position, boss **698** abuts the exposed inner conductive surface of ground plate **620**. This completes a ground path from heat sink **654** to ground wire **680** through the fasteners **657**, ground plate **696** and ground plate **620**.

The ground protected connector sleeve embodiments of FIGS. **14** and **15** provide additional options for safely grounding linear LED tube lamps. With the connector sleeve providing ground protection for the heat sink, the configuration of the connector system at opposite power input end may be simplified. In a preferred aspect, the connector sleeve provides a ground path for the heat sink and the snap-fit connector at the opposite power end is adapted to provide isolated grounding of the LED emitter boards and other internal electronic components such as by using a dedicated ground pin as disclosed in FIG. **13**. This results in a fully grounded lamp having a simplified overall design.

FIG. **16** illustrates another embodiment of the grounding system of the invention for ground protecting both the LED tube lamp heat sink and its internal LED emitter board and other internal electronic components. This embodiment illustrates an implementation of the invention in which ground protection is provided through use of a third L-shaped pin associated with the lamp end cap assembly. The body of multi-sided LED tube lamp **350** of this embodiment is substantially similar to the lamp shown in FIG. **13**, and the description of like components is not repeated. The lamp **350** of FIG. **16** includes an internal driver board **352** with corresponding pin connector **353** mateable with one of the terminals **365** of end connector board **360**. L-shaped pins **362**, **364** and **366** are mounted to support board **361** and include stem portions that seat within corresponding mounting apertures of PCB end connector board **360**. Alternatively, the support board **361** may be eliminated and the pins mounted directly to PCB end connector board **360**.

The connector system **300** of the embodiment of FIG. **16** includes first connector part **310** formed as part of first end cap assembly **314** and second connector part **320** secured to support **50**. The first connector part **310** and second connector part **320** function to form a snap-fit mechanical connection in the same way described previously in relation to the FIG. **13** and other embodiments. The first end cap assembly **314** is essentially the same as that of the embodiment of FIG. **13** except that ground plate **332** has been eliminated. In this embodiment, the ground strap **228a** has also been eliminated from the second connector part **320**.

The L-shaped electrical connector components **362**, **364** of this embodiment are in the form of pins having engagement portions that insert into corresponding spaced receptacles **346**, **344** extending within second connector part **320**. The pins cooperate with connector assemblies **72**, **74** having wires and corresponding connector terminals that extend through the second connector part **320** to establish electrical connection with the pins and thereby form an electrical path between the lamp internal components and the power supply. The connector components or pins **362**, **364** are mechanically and electrically connected to the end connector board **360**, and the board includes traces to provide electrical paths from the connector components to terminals such as terminals **365**. The terminals **365** cooperate with pins **372** extending from LED emitter boards and pins **353** extending from the driver circuit board **352** to provide power to those components. Thus an electrical path is established between the power supply and the internal componentry of

the LED tube lamp **350** when the first and second connector parts of connector **300** are in the engaged configuration.

In the embodiment shown, the heat sink and/or lamp electronic components are ground protected through the third L-shaped connector component **366**, which functions as a dedicated grounding pin. The second connector part **320** has a female receptacle **342** adapted to receive the vertically extending engagement portion of the ground pin **366** when the first and second connector parts **310**, **320** are in the assembled configuration. Receptacle **342** includes an internal connector component (not shown) that forms an electrical path with ground wire **76** to enable the ground pin **366** to provide ground protection for linear LED lamp **350**. In a preferred aspect, end connector board **360** includes traces electrically connecting ground pin **366** to one of the terminals **365** to provide an isolated grounding path for the internal components of the lamp **350** connected to the terminals **365**. In another aspect, ground pin **366** may also be electrically connected to wire **367**. The wire may be utilized to form a mechanical ground connection to the heat sink or to a pad on driver circuit board **360**. In another aspect, the heat sink may be grounded by means of internal electrical traces in end connector board **360** which connect ground pin **366** to conductive edge portions of one or more screw receiving recesses that engage a corresponding assembly screws **334** when the end cap is assembled to the heat sink.

LED lighting products as well as the systems in which they are used are subject to safety and electrical isolation requirements, which are defined in safety standards. Various standards organizations around the world determine individual standards and issue approvals or certificates for equipment and products. Some important standards bodies include Underwriters Laboratories (UL), the American National Standards Institute (ANSI), the International Electrotechnical Commission (IEC), the Canadian Standards Association (CSA) and the Deutsche Elektotechnische Kommission (DKE). The equipment level specifications reference general standards on insulation, such as: IEC60664—Insulation coordination for equipment within low-voltage systems, and UL840—Insulation coordination including clearances and creepage distance for electrical equipment. Besides equipment level specifications there are component level standards.

The distance between components that is required to withstand a given voltage is specified in terms of “clearance” and “creepage.” Creepage distance is defined as the shortest path between two conductive materials measured along the surface of an isolator which is in between. Creepage is an important characteristic because reduced creepage will result in the flow of current or “tracking” along the surface of the insulation. Tracking causes localized heating and carbonization of the surface, and may lead to failure of the insulation. The Comparative Tracking Index (CTI) is used to measure the electrical breakdown (tracking) properties of an insulating material. Creepage also depends on contamination of the surface, humidity, corrosive chemicals and the altitude in which the equipment is installed. Clearance distance describes the shortest distance between two conductive materials measured through air. Sufficient clearance distance prevents an ionization of the air gap and a subsequent flashover. Similar to creepage distance, the pollution degree, temperature and relative humidity influence the tendency for a breakdown.

FIG. 16 illustrates a preferred arrangement of the electrical connector components **362**, **364** and the ground electrical connector component **366** to satisfy the spacing distance between electrical conductors required for a wide range of

voltage levels, as well as to assure that the system is grounded before external power is applied. Ground pin **366** is shown mounted at a laterally centered position, and the power electrical connector components **362**, **364** are mounted on opposite sides of the board’s lateral midline and spaced approximately equally therefrom. Ground pin **366** attaches to support board **361**, and to end connector board **360**, at a position vertically offset from the connector components **362**, **364**, and the tip of its vertically extending engagement portion protrudes above the tip of the vertically extending engagement portions of connector components **362**, **364** in the vertical direction. The internal connector components preferably extend approximately the same distance within second connector part **320** so that their ends are generally aligned at a position adjacent the leading end face thereof, and preferably at a position recessed from the leading end face. As first end cap assembly **314** is moved upward into an engaged configuration and the pins insert into the corresponding receptacles of second connector part **320**, ground pin **366** will engage its corresponding internal connector component to form an electrical ground circuit for the linear LED lamp before the connector components **362**, **364** engage their corresponding connector components of second connector part **320**. This enhances overall safety by assuring the system is grounded before power is applied to the linear LED lamp. This is illustrated further in relation to the embodiment illustrated in FIGS. 17 to 21, and in particular FIGS. 19a and 19b and the corresponding discussion below.

The horizontal leg portions of L-shaped electrical connector components **362**, **364** shown in FIG. 16 extend further in the longitudinal direction of the linear LED lamp **350** than the horizontal leg portion of ground electrical connector component **366**. The illustrated positioning and configuration of the connector components **362**, **364** and **366** provides increased creepage distance between these components, allowing the connector system to satisfy creepage requirements over a wide range of voltage operations. This is explained more fully in relation to the embodiment of FIGS. 17 to 21, which illustrates a similar connector system for a generally cylindrical linear LED lamp.

The linear LED lamp and connector system illustrated in FIGS. 17 to 21 is similar to the embodiments described FIGS. 10 to 12 but utilizes a third ground pin instead of an end cap ground plate and external strap system for providing ground protection to the lamp heat sink and internal components. LED tube lamp **750** comprises an elongate tubular body portion including a metallic heat sink **754** extending throughout a generally upward facing portion of the circumference of the tubular body, and a transparent or translucent lens portion **752** extending throughout a generally downward facing portion of the circumference of the tubular body. The heat sink is preferably formed of an aluminum alloy, although other thermally conductive materials may be used. At least one LED emitter panel **770** comprising a printed circuit board mounting a series of LEDs is mounted to the heat sink internal to the tubular body. The heat sink may include fins **755** extending along its length to increase the effective surface area for transfer of heat to the atmosphere. The LED lamp **750** may include an internal ballast or driver module (not shown) or may alternatively utilize an external ballast associated with the lighting fixture. Heat sink **754** has a generally semi-circular cross-section in a plane perpendicular to the length of the lamp, with support wall **759** extending across the internal region thereof to provide a mounting surface for LED emitter panel **770**. Other heat sink geometries are also contemplated, including,

for example, a configuration such as the one illustrated in FIG. 16 comprising multiple support walls arranged in a generally V-shape and lying in intersecting planes for supporting multiple LED emitter panels arranged to distribute light over a wide area.

With further reference to FIG. 17, LED lamp 750 is mounted at its first end to a support of a lighting fixture (not shown) by means of snap-fit connector system comprising first connector part 710 and second connector part 720 configured to mount to the support. The second connector part 720 can be press connected to tabs of the support by means of oppositely opening slots formed between flanges 724 and flanges 723 extending outwardly from opposite sidewalls of second connector part 720. Of course other releasable, and potentially permanent, connections are contemplated.

As is further illustrated in FIGS. 19a and 19b, the second connector part 720 has a pair of bendable parts 722 on opposite sides thereof, each operable through hinge 725, which are engaged by the edge of the opening 716 and progressively cammed from a holding position towards an assembly position as the first connector part 710 is moved up to and into the engaged position. The first bendable parts 722 move from the assembly position back towards the holding position with the first part realizing the engaged position. The wall 714 resides captively between surfaces of the first connector part 710 in the engaged position to maintain this snap-fit connection. A pair of actuators 721 on opposite sides of second connector part 720 can be pressed to move the first bendable parts 722 towards its assembly position to allow them to pass through the opening 716 so that first connector part 710 can be separated from the second connector part 720. Second connector part 720 includes a curved concave ledge portion 732 at the juncture of sidewall 730 and sidewall 740 and has a generally planar opposite outer sidewall. This permits the second connector part 720 to insert further into the interior of first connector part 710, with a portion of the convexly curved outer wall portion of first connector part 710 seating within the curved ledge portion 732.

Heat sink 754 has a planar end face 758 at a first end thereof defining a pair of apertures 757. Connector end board 760 includes a pair of corresponding notches 753 aligned with heat sink apertures 757. The end wall of first end cap assembly 714 defines corresponding aligned apertures 736. The end cap assembly 714 and connector board 760 may be secured to heat sink 754 at the first end of LED tube lamp 750 with a pair of metallic fasteners (not shown) extending through the corresponding apertures and into the end face 758 of the heat sink. When assembled, the end board 760 and end portions of the heat sink and translucent lens portion 752 reside within the receptacle of end cap assembly 714.

As FIG. 17 illustrates, the receptacle of end cap assembly 714 may receive end connector board 760 having L-shaped electrical connector components 762, 764 and 763 thereon that cooperate with connector assemblies 72, 74 and 76 of second connector part 720. The connector assemblies have wires terminated with conductive cylindrical terminals 72a, 74a and 76a respectively that extend into the receptacles of second connector part 720. The wires of assemblies 72 and 74 connect to a power supply and the third wire 76 provides an isolated ground circuit. The connector components 762 and 764 may connect to LED emitter board 770 by means of wires 766 and may similarly provide power to other internal components of linear LED lamp 750. In one aspect, wires 766 connect to an internally mounted driver to provide AC

line voltage which the driver converts to DC voltage supplied to the LED emitter board and optionally other internal componentry. The ground connector 763 may connect via wire 767 to the heat sink or to an internal driver board.

The L-shaped electrical connector components 762, 764 and 763 on the connector board 760 each have a first portion extending horizontally in direction generally parallel to the length of the body and a second engagement portion extending vertically in a direction traverse to the length of the body and towards the second connector part 720 when said first connector part 710 is moved towards the second connector part and into the engaged position. The vertically extending engagement portions insert into corresponding spaced receptacles 744, 746 and 742 respectively in the leading end of second connector part 720 and engage the connector terminals 74a, 72a and 76a respectively that extend within the second connector part 720 to establish electrical connections with the power supply and a grounding circuit. FIG. 18 provides a perspective view showing the interaction of the components in the fully engaged configuration.

Although the embodiment illustrated in FIG. 17 utilizes internal wire connections, the connector board 760 may alternatively be in the form of a printed circuit board (PCB) connector containing male or female electrical terminals for connecting to corresponding terminals associated with LED emitter board 770, a driver circuit or other internal components of the lamp to provide a no-wire design. In both approaches, connector components 762, 764 provide an electrical path over which electrical power from a power supply is provided to the LED emitter board 770 and optionally other internal components, and the connector component 763 provides a grounding circuit.

The configuration of the L-shaped connectors shown in FIG. 17 is similar to that of the configuration shown in embodiment of FIG. 16. The advantages of this configuration in relation to satisfying spacing distance requirements between electrical conductors and other standards requirements is further explained by reference to FIGS. 19a, 19b, 20a, 20b, 21a and 21b.

FIG. 19a shows that ground connector component or pin 763 is mounted at a laterally centered position, and the power electrical connector components 762, 764 are mounted on opposite sides of the vertical diameter of support board 760 and spaced approximately equally therefrom. Ground pin 763 attaches to support board 760 at a position vertically offset from the connector components 762, 764, and the tip of its vertically extending leg protrudes above the tip of the vertically extending legs of connector components 762, 764 in the vertical direction. The internal connector terminals 72a, 74a and 76a extend approximately the same distance within second connector part 720 to positions offset from the leading end face thereof by the dimension shown as D3. As first end cap assembly 714 is moved upward into an engaged configuration and the pins insert into the corresponding receptacles of second connector part 720, ground pin 763 will engage its corresponding internal connector component to form an electrical ground circuit for the linear LED lamp before the connector components 762, 764 engage their corresponding connector components of second connector part 720, as shown in FIG. 19a.

FIG. 19b shows the relative positioning of the components with the first connector part 710 and second connector part 720 in the engaged position. In this embodiment, second connector part 720 is configured so that its leading end extends internally approximately one-half of the vertical diameter of end cap assembly 714 in the view shown. The

vertical portions of connector components **762**, **764** and **763** are of sufficient length so that they insert into the cylindrical terminals **74a**, **72a** and **76a** respectively in the engaged position. The connector components may have a predetermined length selected to meet a minimum desired distance over which the connector components engage the terminals. For example, the vertical portions of connector components **762** and **764** extend the distance **D4** from the centerline of the end cap assembly, and the pin engagement distance when the components are assembled is represented by **D4** minus **D3**. In a preferred embodiment, the pins are configured to provide a pin engagement distance of at least 4.0 mm, and more preferably at least 4.3 mm.

FIG. **20a** is end view of the second connector part **720** showing the arrangement of receptacles **744**, **746** and **742** accessible through openings in the end face of the leading end thereof. The connector terminals **74a**, **72a** and **76a** housed within the receptacles are also shown. The shortest distance between adjacent conductors along the surface of the end face is the distance from the outer edge of receptacle openings **742** and **744**, which is labeled as **D1**. This dimension is preferably at least about 2.0 mm to provide adequate electrical isolation at higher voltage operation. The outer edges of receptacle openings **746** and **744** for the power terminals are preferably spaced by at least 2.8 mm. As shown in the side view of FIG. **20b**, the distance from the end of the terminals to the end face of second end connector **720** is **D3**. This dimension is preferably at least about 5.5 mm to provide adequate electrical isolation at higher voltage operation. Accordingly, the shortest path between two adjacent connector terminals measured along the surface of the isolator between them is the sum of **D3** and **D1** and **D3**. In a preferred form, second connector part **720** may be dimensioned such that this creepage distance is at least about 13.0 mm.

FIG. **21a** shows a view of end cap assembly **714** from above, looking into opening **716**. The clearance distance separated by air between any portion of adjacent connector components is preferably at least 3.0 mm, and more preferably at 3.2 mm to provide for safe operation at voltage levels up to 600 volts. The shortest distance separated by air between vertical legs of adjacent connector components is the distance between the vertical engagement portion of ground connector component **763** and the vertical engagement portion of either of the power connector components **762** and **764**, which is designated **D2** in FIG. **21a**. This distance is preferably controlled to provide minimum clearance of at least 3.5 mm.

The ground protected connector systems disclosed herein provide safe and reliable means for securing linear LED tube lamps to a lighting fixture. The disclosed ground protected systems alleviate all safety concerns, permit high power operation, provide for flexible lamp design and installation options, and can be implemented in a cost-effective manner.

In a preferred aspect, the linear lamp **750** illustrated in FIGS. **17** to **21** connects to the support **50** of the lighting fixture by means of a similar second snap-fit connector system at its opposite end. The second snap-fit connector system need not include electrical connector terminals and may be provided without a means for connecting to the power supply. The opening **716** in first connector part **710** is preferably slightly larger than the corresponding dimensions of the leading end of connector **720**, and the same relative sizing is preferable for the end cap assembly and support connector at the opposite lamp end. Sufficient clearance between the end cap openings and the leading end of the support connectors permits lamp **750** to be shifted slightly

relative to the support connectors along the direction of its length or transverse to its length so that the vertical extending portions of connector components **764**, **762** and **763** can be readily aligned with and inserted into receptacles **744**, **746** and **742** during lamp installation.

FIG. **22** shows an alternative approach in which the opposite end of lamp **750** is connected to the fixture support by means of the cylindrical connector sleeve **520** shown previously in FIG. **9**. The above description of connector sleeve **520** and its advantages is not repeated. The use of connector sleeve **520** may provide for easier installation, as discussed above. It also accommodates small variations in lamp length by permitting the lamp to be shifted linearly during installation so that connector components **764**, **762** and **763** align with and inserted into receptacles **744**, **746** and **742**. Of course, connector sleeves comprising a sleeve portion of other cross-sectional geometries, such as generally triangular, square or rectangular, are also contemplated for use with other lamps having corresponding end cap cross-sectional geometries.

Those skilled in the art will recognize that a wide variety of modifications, alterations, and combinations can be made with respect to the above described embodiments without departing from the spirit and scope of the invention, and that such modifications, alterations, and combinations, are to be viewed as being within the scope of the invention.

What is claimed is:

1. A support connector for maintaining an end of a linear LED lamp in an operative state on a support, the linear LED lamp having a body with a length between spaced first and second ends, a source of illumination comprising LED emitters on or within the body, and a first end cap assembly at the first end of the body comprising a housing having a sidewall extending in a direction generally parallel to the length of the body and having first and second conductive power pins and a conductive grounding pin disposed within the housing, at least one of the conductive power pins adapted to provide power to the lamp and the conductive grounding pin being connectable to a ground circuit, the pins each having an elongated engagement portion extending in a direction transverse to the length of the body and towards an opening in the sidewall, the support connector comprising:

- a nonconductive housing comprising a first portion including a mounting base at one end of the first portion configured to couple the support connector to the support;
- a second portion extending from the opposite end of the first portion and configured to be insertable within the opening of the first end cap assembly;
- the second portion having generally parallel first and second sides and a leading end wall extending transverse to the sides, the leading end wall defining first, second and third openings, and spaced first, second and third elongated receptacles extending generally parallel to each other through the second portion in communication with the openings;
- first and second power electrical terminals disposed within the first and second receptacles respectively in general alignment with a corresponding one of the first and second openings, and a grounding electrical terminal disposed within the third receptacle in general alignment with the third opening, the grounding electrical terminal electrically isolated from the first and second power terminals;
- the first and second power electrical terminals configured to mate with the engagement portion of a respective

25

one of the first and second conductive power pins when the power pins are inserted into the first and second receptacles through the respective first and second openings, and the grounding electrical terminal configured to mate with the engagement portion of the conductive grounding pin when the grounding pin is inserted into the third receptacle through the third opening, as the first end cap assembly is moved relative to the support connector from a position fully separated from the support connector in a path that is transverse to the length of the body into an engaged position; the second portion having first and second parts on which respective second surfaces are defined, the second surfaces configured to engage corresponding first surfaces defined by the an inner surface of the sidewall of the first end cap assembly housing adjacent opposite ends of the opening so that the first and second surfaces are placed in confronting relationship to couple the first end cap assembly to the support connector with the body in the operative state in the engaged position.

2. The support connector according to claim 1, wherein the grounding electrical terminal is spatially arranged relative to the first and second power electrical terminals such that, when the first end cap assembly is moved towards the engaged position, the conductive grounding pin will be electrically coupled to the grounding electrical terminal before the first and second conductive power pins are electrically coupled to the first and second power electrical terminals.

3. The support connector according to claim 1, wherein the first and second parts are retractable parts, and the second portion of the housing is configured so that the first end cap assembly moves against the second portion as the first end cap assembly moves toward the engaged position thereby causing the first and second retractable parts to reconfigure to allow the first and second surfaces to be placed in confronting relationship.

4. The support connector according to claim 3, further comprising a first actuator operatively coupled to the first retractable part and a second actuator operatively coupled to the second retractable part, the support connector configured so that with the first end cap assembly in the engaged position the actuators can be deployed to thereby reposition the first and second retractable parts so that the second surfaces are out of the confronting relationship with the first surfaces to allow the first end cap assembly to be separated from the support connector.

5. The support connector according to claim 1, wherein the first and second conductive power terminals are each configured to be electrically connected with a power supply.

6. The support connector according to claim 5, wherein the support is a component of a light fixture and the grounding terminal is configured to be electrically connected with a conductive portion of the light fixture.

7. The support connector according to claim 5, wherein the support is a component of a light fixture and the grounding terminal is configured to be electrically connected with a ground circuit external of the light fixture.

8. The support connector according to claim 1, wherein the first and second power electrical terminals and the grounding electrical terminal are spatially arranged within the respective corresponding receptacles of the second portion of the housing so that each pin engages its corresponding terminal over a linear distance of at least about 4 mm with the first end cap assembly and support connector in the engaged position.

26

9. The support connector according to claim 1, wherein the first and second power electrical terminals and the grounding electrical terminal extend within the respective corresponding receptacles of the second portion of the housing to positions spaced from the leading end wall thereof.

10. The support connector according to claim 9, wherein the first and second power electrical terminals and the grounding electrical terminal extend within the respective corresponding receptacles of the second portion of the housing to positions spaced from the leading end wall thereof by at least about 5.5 mm.

11. The support connector according to claim 1, wherein the first and second power electrical terminals and the grounding electrical terminal are electrically isolated from each other by intermediate nonconductive material of the housing.

12. The support connector according to claim 11, wherein the first, second and third openings in the leading end wall of the second portion of the housing are in a triangular arrangement.

13. The support connector according to claim 12, wherein the first and second openings are separated from each other by at least about 2.8 mm, and the third opening is separated from each of the first and second openings by at least about 2 mm.

14. The support connector according to claim 11, wherein the support connector is rated for safe operation at voltage levels up to about 600 volts.

15. The support connector according to claim 1, wherein the second portion of the housing has a reduced outer profile relative to the first portion of the housing forming a ledge portion at the juncture of the first portion and the second portion of the housing.

16. The support connector according to claim 15, wherein a portion of the sidewall of the first end cap assembly housing adjacent the opening resides captively between the ledge portion and the second surfaces of the first and second parts with the support connector and first end cap assembly in the engaged position.

17. The support connector according to claim 16, wherein the sidewall of the first end cap assembly is convexly curved and a surface of the ledge portion of the support connector has a concave curved profile that generally corresponds to the curvature of the sidewall.

18. The support connector according to claim 16, wherein the sidewall of the first end cap assembly is generally planar and the ledge portion of the support connector has a corresponding generally planar profile.

19. The support connector according to claim 1, wherein the mounting base is configured to mount the support connector to a support of a light fixture.

20. The support connector according to claim 19, wherein the light fixture is a standard fluorescent tube lamp light fixture.

21. The support connector according to claim 19, wherein the mounting base comprises a flange, a lower facing surface of the flange engaging an upper facing surface of the light fixture support with the support connector coupled to the light fixture support.

22. The support connector according to claim 19, wherein first portion comprises first and second oppositely facing sides and the mounting base comprises an externally facing slot in each side adapted to engage an edge portion of an opening in the light fixture support.

23. The support connector according to claim 19, wherein the light fixture support comprises a reflector and the support

connector is a component separate from the reflector and the mounting base is configured to be press connected to the reflector.

* * * * *