



US009470401B2

(12) **United States Patent**
May

(10) **Patent No.:** **US 9,470,401 B2**

(45) **Date of Patent:** **Oct. 18, 2016**

(54) **LIGHTING ASSEMBLY**

(71) Applicant: **Michael W. May**, Lakewood, IL (US)

(72) Inventor: **Michael W. May**, Lakewood, IL (US)

(*) Notice: Subject to any disclaimer, the term of this patent is extended or adjusted under 35 U.S.C. 154(b) by 0 days.

(21) Appl. No.: **14/982,513**

(22) Filed: **Dec. 29, 2015**

(65) **Prior Publication Data**

US 2016/0258581 A1 Sep. 8, 2016

Related U.S. Application Data

(63) Continuation of application No. 14/256,066, filed on Apr. 18, 2014, now Pat. No. 9,228,727, which is a continuation-in-part of application No. 13/440,423, filed on Apr. 5, 2012, now Pat. No. 8,702,265.

(51) **Int. Cl.**

F21V 19/00 (2006.01)
F21V 5/04 (2006.01)
F21V 21/005 (2006.01)

(Continued)

(52) **U.S. Cl.**

CPC **F21V 19/0085** (2013.01); **F21K 9/17** (2013.01); **F21K 9/175** (2013.01); **F21S 8/04** (2013.01); **F21V 5/04** (2013.01); **F21V 21/005** (2013.01); **F21V 23/003** (2013.01); **F21V 23/06** (2013.01); **F21V 29/70** (2015.01); **F21V 29/89** (2015.01);

(Continued)

(58) **Field of Classification Search**

CPC F21K 9/17; F21K 9/175; F21S 8/04; F21V 5/04; F21V 19/0085; F21V 21/005; F21V 23/003; F21V 23/06; F21V 29/70; F21V 29/89; F21Y 2101/02; F21Y 2103/003

See application file for complete search history.

(56) **References Cited**

U.S. PATENT DOCUMENTS

1,516,721 A 11/1924 Emery
1,941,079 A 12/1933 Exelmans

(Continued)

FOREIGN PATENT DOCUMENTS

CN 1690505 A 11/2005
CN 201448641 U 5/2010

(Continued)

OTHER PUBLICATIONS

Notification of Transmittal of the International Search Report and the Written Opinion of the International Searching Authority, or the Declaration from the International Bureau of WIPO for corresponding International Application No. PCT/US2012/037242, dated Aug. 13, 2012, 13 pages.

(Continued)

Primary Examiner — Stephen F Husar

(74) *Attorney, Agent, or Firm* — Fitch, Even, Tabin & Flannery LLP

(57)

ABSTRACT

An elongate tubular lighting assembly having a body with a length between spaced first and second ends. The tubular lighting assembly has a source of illumination and first and second connectors respectively at the first and second body ends. The first connector has cooperating first and second parts having first and second surfaces. The first and second connector parts are configured so that the first and second surfaces are placed in confronting relationship to prevent separation of the first and second connector parts with the body in an operative state as an incident of the first connector part moving relative to the second connector part from a position fully separated from the second connector part in a substantially straight path that is transverse to the length of the body into an engaged position.

20 Claims, 70 Drawing Sheets

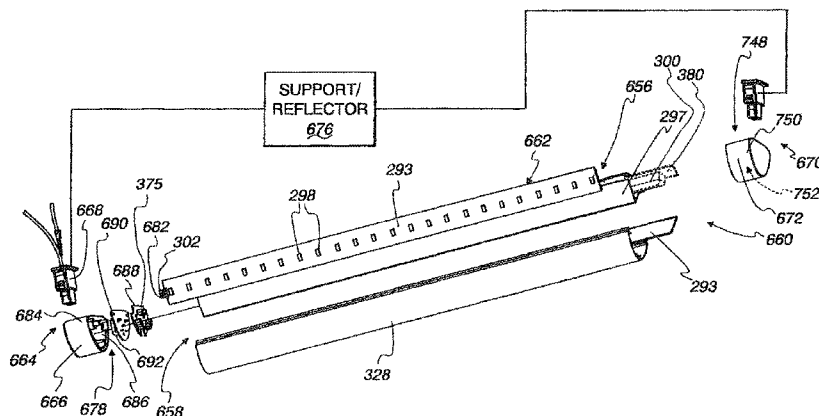

(51)	Int. Cl. <i>F21K 99/00</i> (2016.01) <i>F21V 29/70</i> (2015.01) <i>F21V 29/89</i> (2015.01) <i>F21V 23/06</i> (2006.01) <i>F21V 23/00</i> (2015.01) <i>F21S 8/04</i> (2006.01) <i>F21Y 101/02</i> (2006.01) <i>F21Y 103/00</i> (2016.01)	8,186,847 B2 5/2012 Hu et al. 8,214,084 B2 7/2012 Ivey et al. 8,235,539 B2 8/2012 Thomas et al. 8,247,985 B2 8/2012 Timmermans et al. 8,251,544 B2 8/2012 Ivey et al. 8,256,924 B2 9/2012 Simon et al. 8,282,247 B2 10/2012 Ivey et al. 8,287,144 B2 10/2012 Pedersen et al. 8,324,817 B2 12/2012 Ivey et al. 8,330,381 B2 12/2012 Langovsky 8,360,599 B2 1/2013 Ivey et al. 8,382,327 B2 2/2013 Timmermans et al. 8,408,742 B2 4/2013 Tran D682,463 S 5/2013 Bernard 8,434,891 B1 5/2013 Ham 8,444,292 B2 5/2013 Ivey et al. 8,454,193 B2 6/2013 Simon et al. 8,523,394 B2 9/2013 Simon et al. D691,750 S 10/2013 Mackiewicz D692,597 S 10/2013 Simon et al. 8,571,716 B2 10/2013 Ivey et al. 8,573,813 B2 11/2013 Ivey et al. 8,596,813 B2 12/2013 Ivey 8,616,720 B2 12/2013 Carney et al. D698,075 S 1/2014 Klus 8,628,216 B2 1/2014 Ivey et al. 8,643,298 B2 2/2014 Palazzolo et al. 8,653,984 B2 2/2014 Ivey et al. D701,639 S 3/2014 Maxik et al. 8,664,880 B2 3/2014 Ivey et al. 8,674,626 B2 3/2014 Siemiet et al. 8,678,610 B2 3/2014 Simon et al. 8,702,265 B2 4/2014 May 8,807,785 B2 8/2014 Ivey et al. 8,830,080 B2 9/2014 Ivey et al. 8,919,991 B2 12/2014 Lee et al. 8,956,005 B2 2/2015 Thomas et al. 8,967,825 B2 3/2015 Fukui 2002/0096347 A1 7/2002 Pyron 2004/0095078 A1 5/2004 Leong 2006/0012981 A1 1/2006 Noh 2007/0159828 A1 7/2007 Wang 2007/0246714 A1 10/2007 Koike et al. 2010/0039813 A1 2/2010 Sloan et al. 2010/0079075 A1 4/2010 Son 2010/0254148 A1 10/2010 Huang et al. 2010/0327768 A1 12/2010 Kong et al. 2011/0019421 A1 1/2011 Lai 2011/0199005 A1* 8/2011 Bretschneider F21V 7/22 315/152 2011/0235321 A1 9/2011 Ivey et al. 2011/0280020 A1 11/2011 Chen et al. 2011/0292647 A1 12/2011 Chang 2012/0049739 A1 3/2012 Clough 2012/0069557 A1 3/2012 Bolscher 2012/0201022 A1* 8/2012 van de Ven F21K 9/17 362/218 2013/0141906 A1 6/2013 Wang et al. 2013/0258668 A1 10/2013 Dellian et al. 2013/0279160 A1 10/2013 Myers et al. 2013/0343037 A1 12/2013 Alexander 2014/0218905 A1 8/2014 Ono et al. 2014/0268752 A1 9/2014 Werr et al. 2015/0049475 A1 2/2015 Pan et al.
(52)	U.S. Cl. CPC <i>F21Y 2101/02</i> (2013.01); <i>F21Y 2103/003</i> (2013.01)	
(56)	References Cited U.S. PATENT DOCUMENTS	
	2,628,800 A 2/1953 Kindorf 3,087,982 A 4/1963 Hayes 3,131,871 A 5/1964 Foulds 3,404,268 A 10/1968 Fowler D246,930 S 1/1978 Win 4,115,230 A 9/1978 Beckman 4,156,553 A 5/1979 Ammon et al. 5,106,103 A 4/1992 Fiore 5,434,762 A 7/1995 Shemitz 5,457,905 A 10/1995 Kaplan D397,481 S 8/1998 Schafer D421,815 S 3/2000 Herst et al. D430,326 S 8/2000 Littman 6,107,572 A 8/2000 Miyazaki D438,326 S 2/2001 Kan 6,231,373 B1 5/2001 Daoud 6,257,735 B1 7/2001 Baar 6,283,612 B1 9/2001 Hunter D459,012 S 6/2002 Shemitz et al. D459,517 S 6/2002 Shemitz et al. 6,578,979 B2 6/2003 Truttman-Battig 6,623,151 B2 9/2003 Pederson D500,883 S 1/2005 Herst et al. D500,884 S 1/2005 O'Rourke D503,009 S 3/2005 Salman 7,049,761 B2 5/2006 Timmermans et al. D523,165 S 6/2006 Schultz 7,195,370 B2 3/2007 Riblett et al. D543,305 S 5/2007 Wang D565,785 S 4/2008 Kerr D574,105 S 7/2008 Shuai et al. D575,898 S 8/2008 Tran et al. D581,569 S 11/2008 Levine 7,476,004 B2 1/2009 Chan D589,199 S 3/2009 Pedersen 7,510,299 B2 3/2009 Timmermans et al. 7,513,637 B2 4/2009 Kelly et al. D605,343 S 12/2009 Watt D607,145 S 12/2009 Yu 7,637,636 B2 12/2009 Zheng et al. D616,382 S 5/2010 Lin et al. 7,712,918 B2 5/2010 Siemiet et al. 7,815,338 B2 10/2010 Siemiet et al. D627,095 S 11/2010 Miyairi et al. D634,470 S 3/2011 Hsieh 7,918,580 B2 4/2011 Liu 7,926,975 B2 4/2011 Siemiet et al. 7,938,562 B2 5/2011 Ivey et al. 7,946,729 B2 5/2011 Ivey et al. D642,326 S 7/2011 Leadford et al. 7,976,185 B2 7/2011 Uang et al. 7,976,187 B2 7/2011 Villard 7,976,196 B2 7/2011 Ivey et al. 7,989,827 B2 8/2011 Hsu D649,282 S 11/2011 McDonald et al. 8,052,295 B2 11/2011 Kim et al. 8,093,823 B1 1/2012 Ivey et al. D654,208 S 2/2012 Marquardt et al. 8,118,447 B2 2/2012 Simon et al.	
	FOREIGN PATENT DOCUMENTS	
	CN 101936469 A 1/2011 EP 2418422 A2 2/2012 JP 2007-165051 A 6/2007 WO 2013/121580 A1 8/2013	
	OTHER PUBLICATIONS	
	Notification of Transmittal of the International Search Report and the Written Opinion of the International Searching Authority, or the Declaration from the International Bureau of WIPO for correspond-	

(56)

References Cited

OTHER PUBLICATIONS

ing International Application No. PCT/US15/26409, dated Jul. 30, 2015, 17 pages.

Office Action including Search Report issued in related Chinese Application No. 2012800737587 dated Jan. 28, 2016 (8 pages).
Extended European search report issued in the related European Application No. 12873713.7-1757 dated Jan. 29, 2016 (9 pages).

* cited by examiner

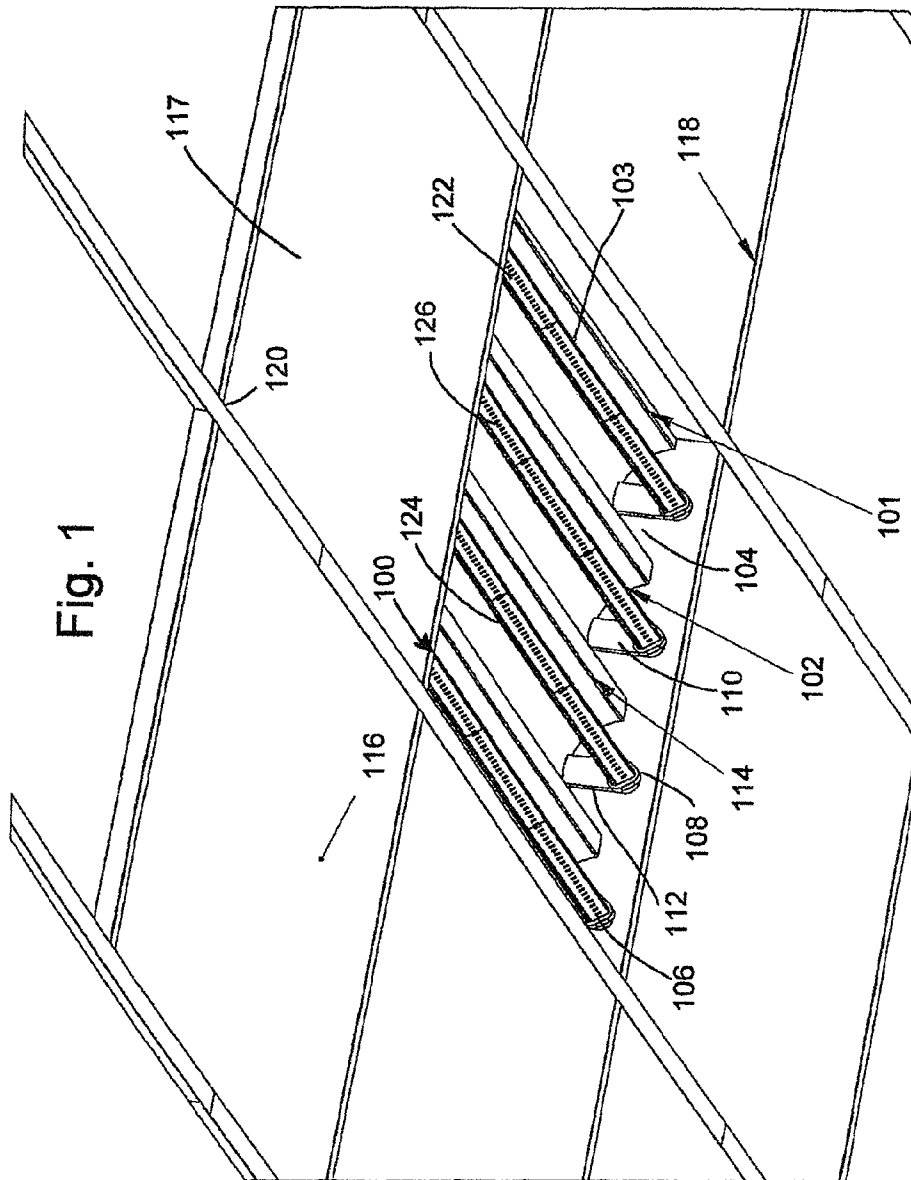

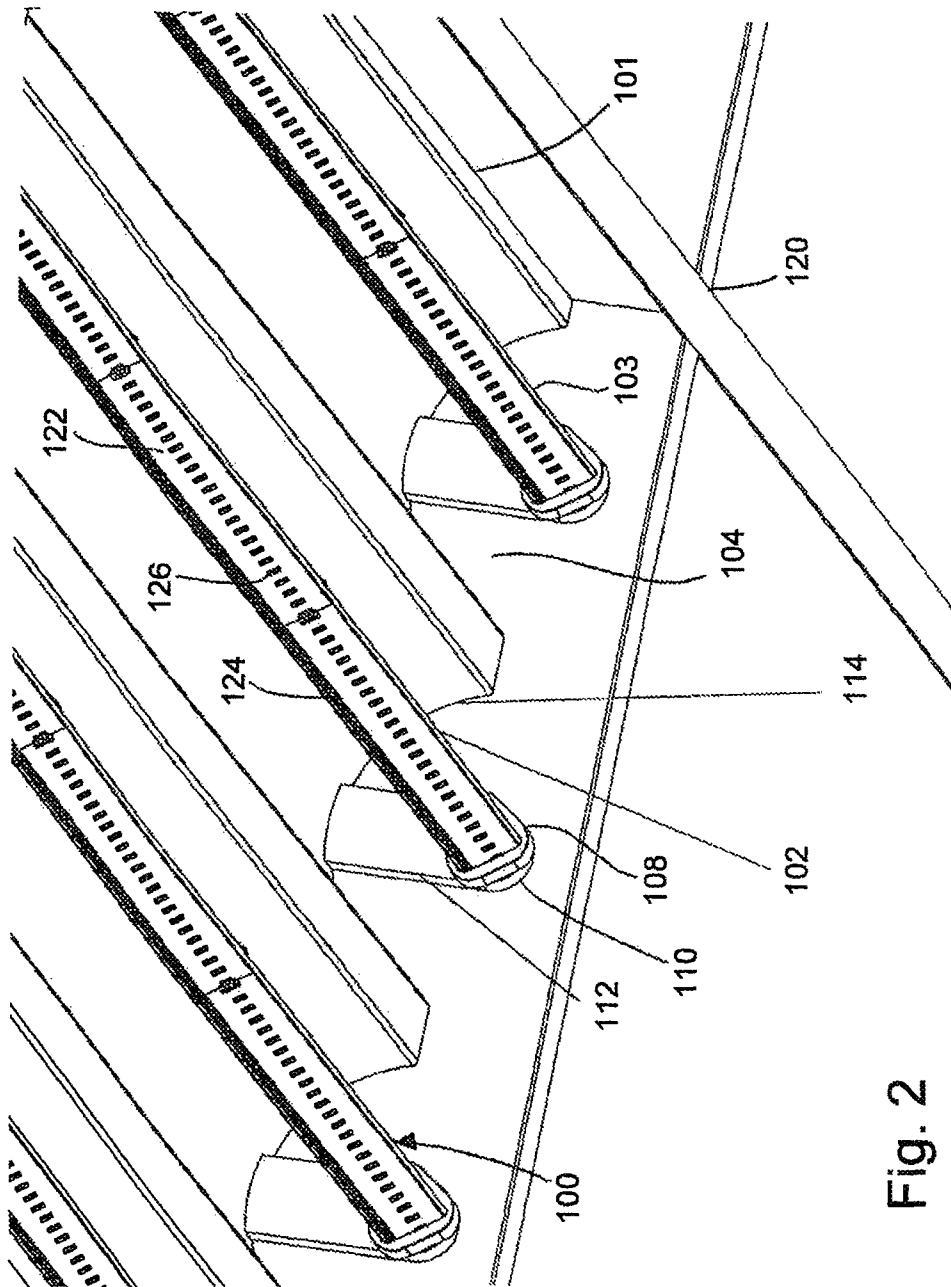

Fig. 2

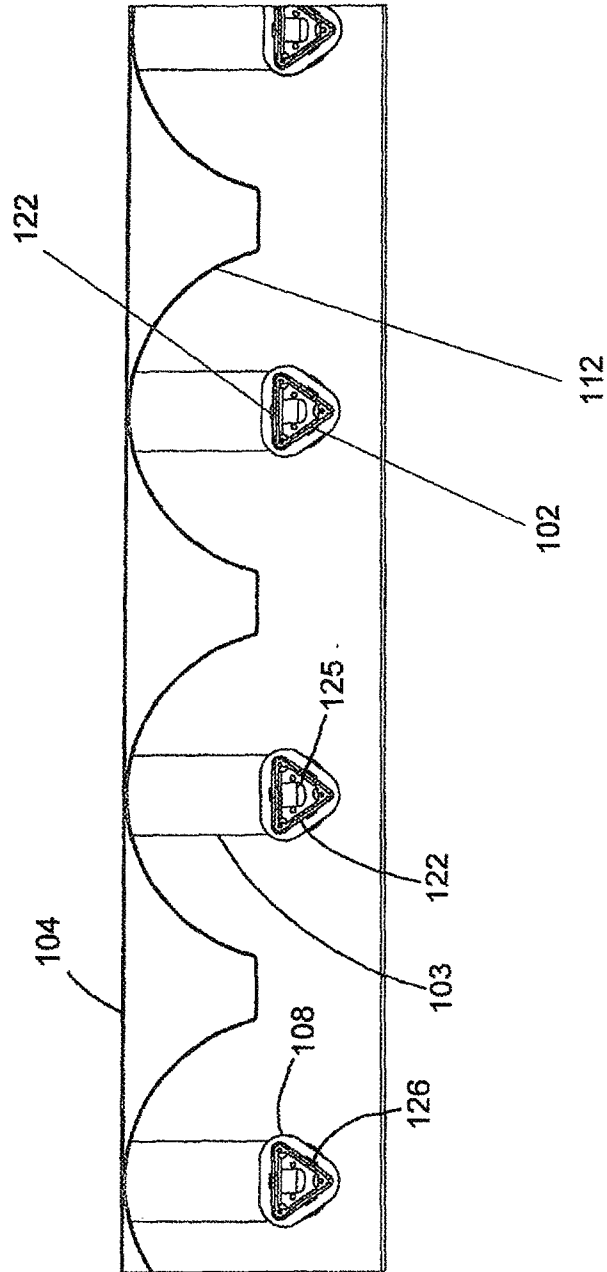

Fig. 3

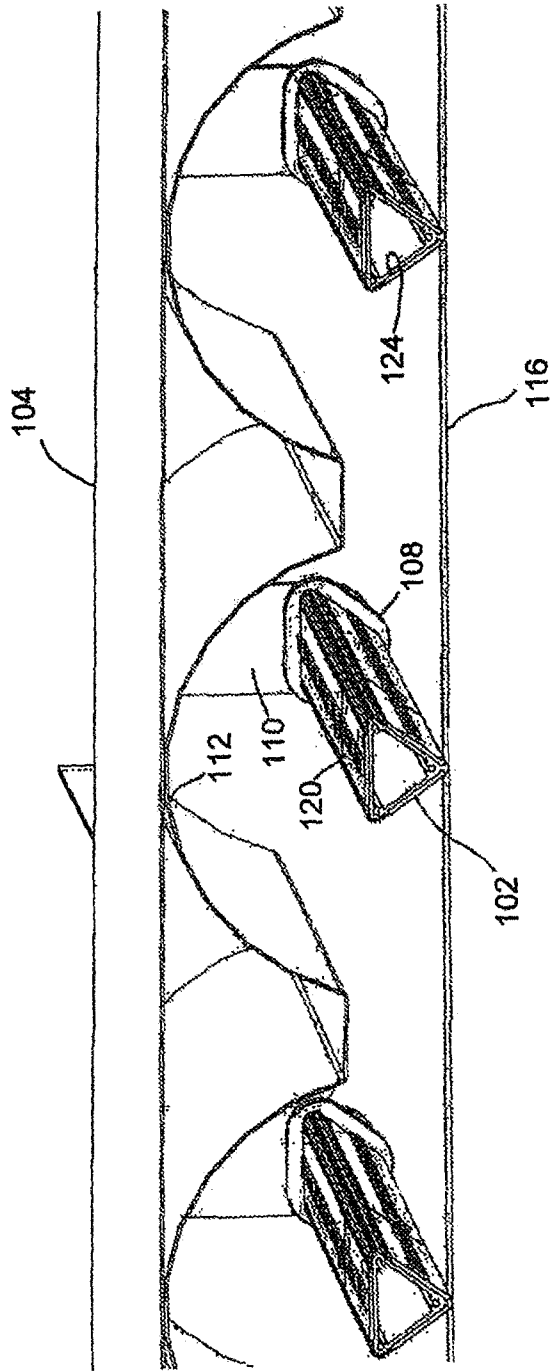

Fig. 4

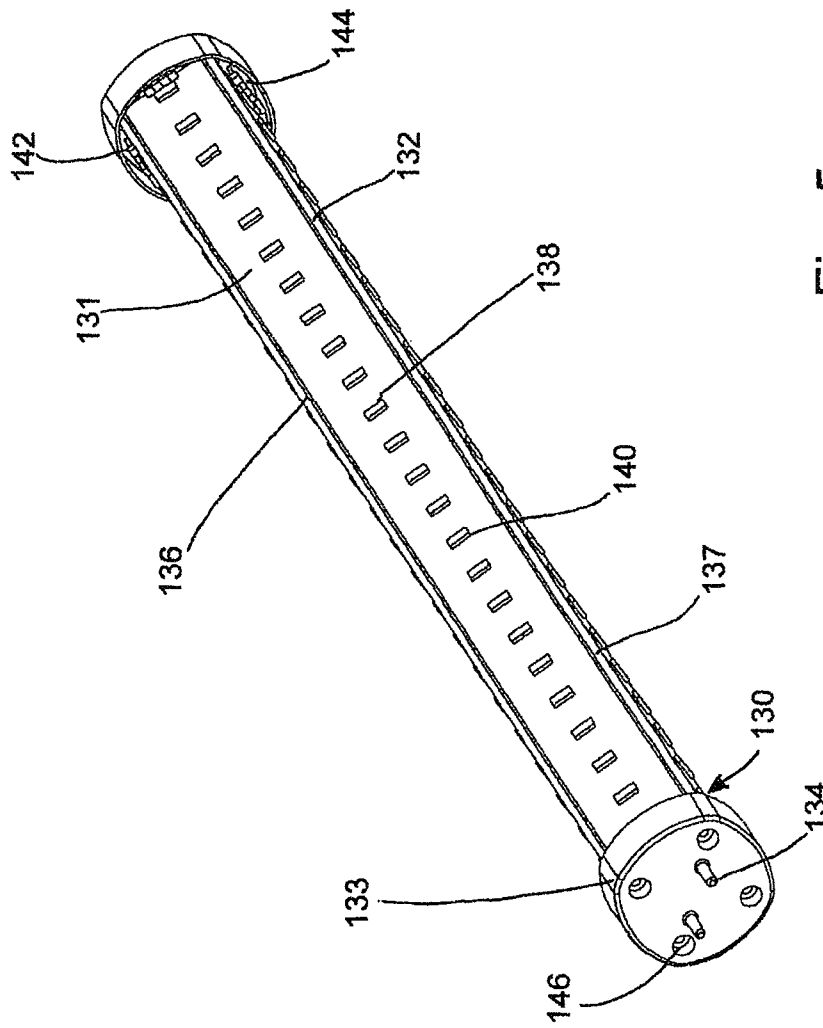

Fig. 5

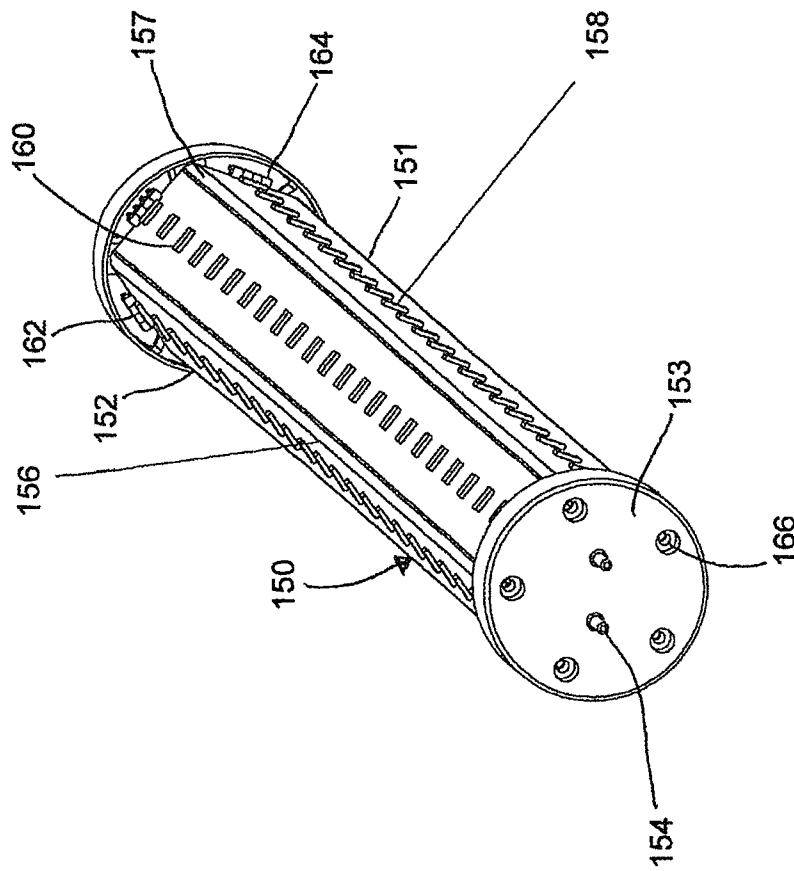

Fig. 6

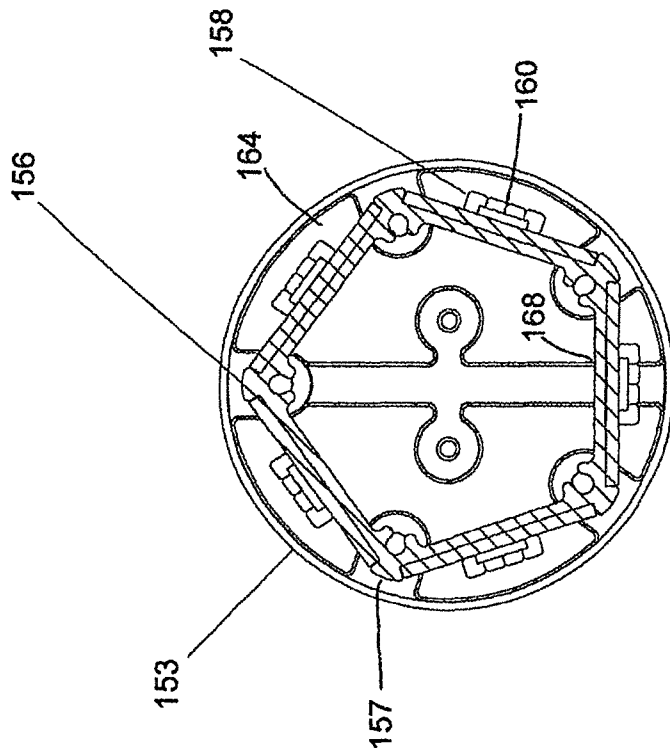

Fig. 7

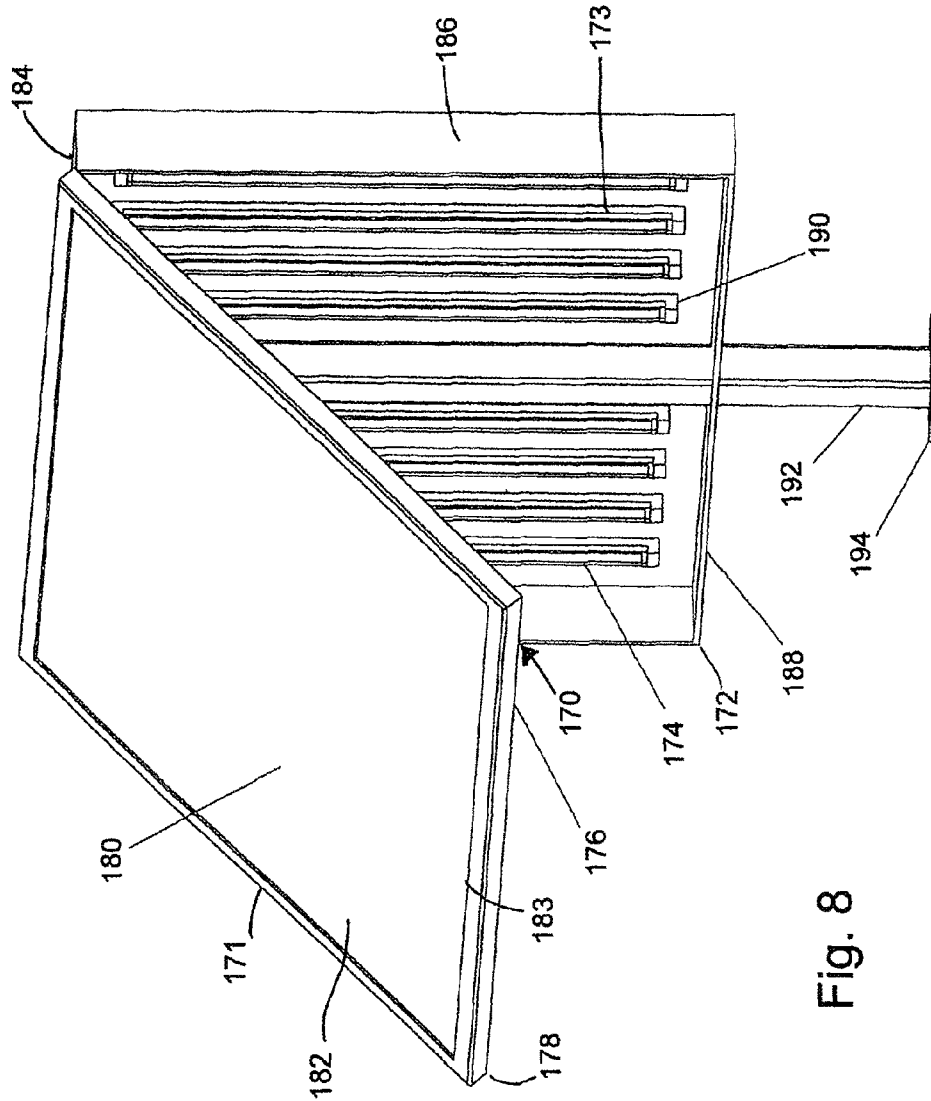
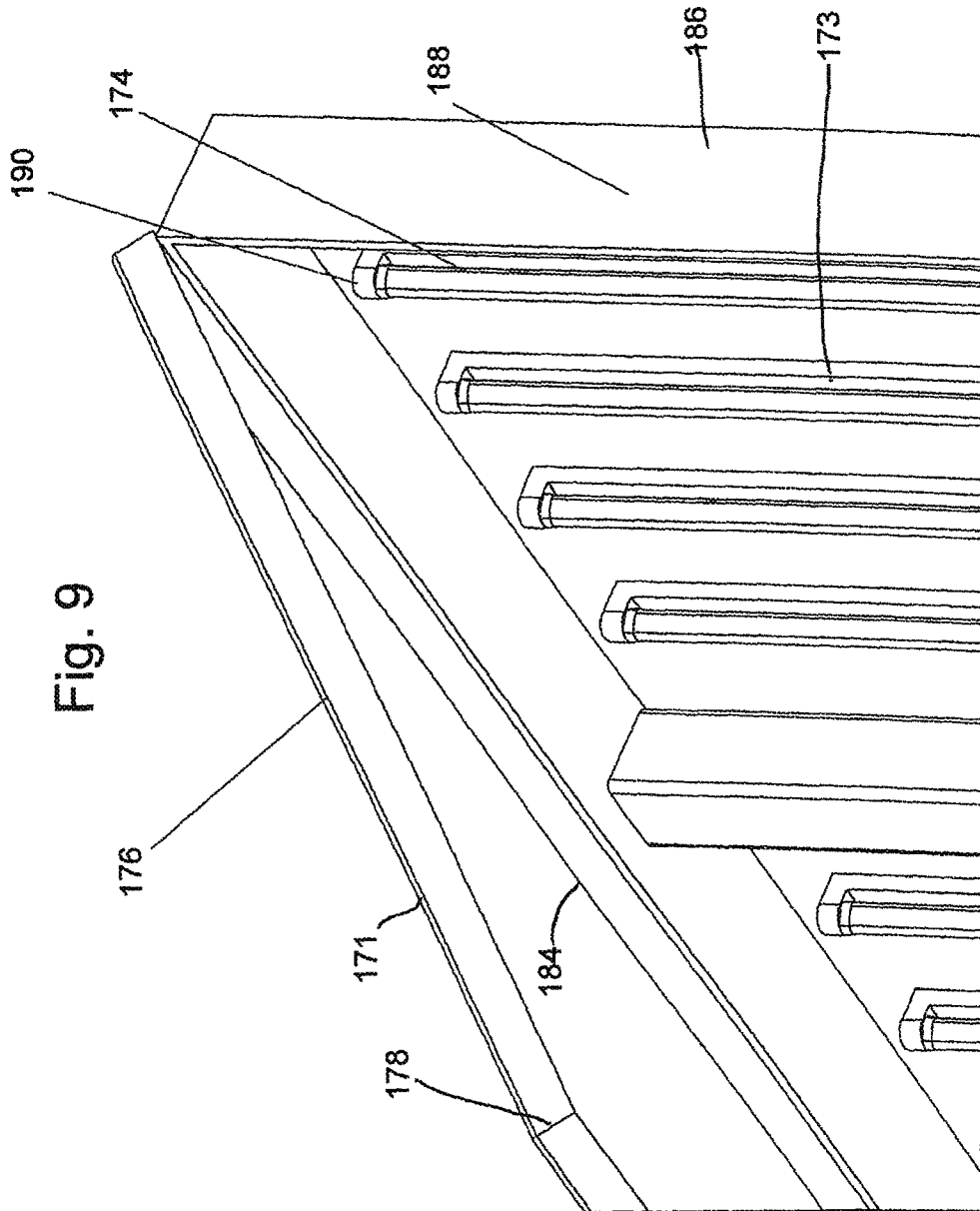

Fig. 8



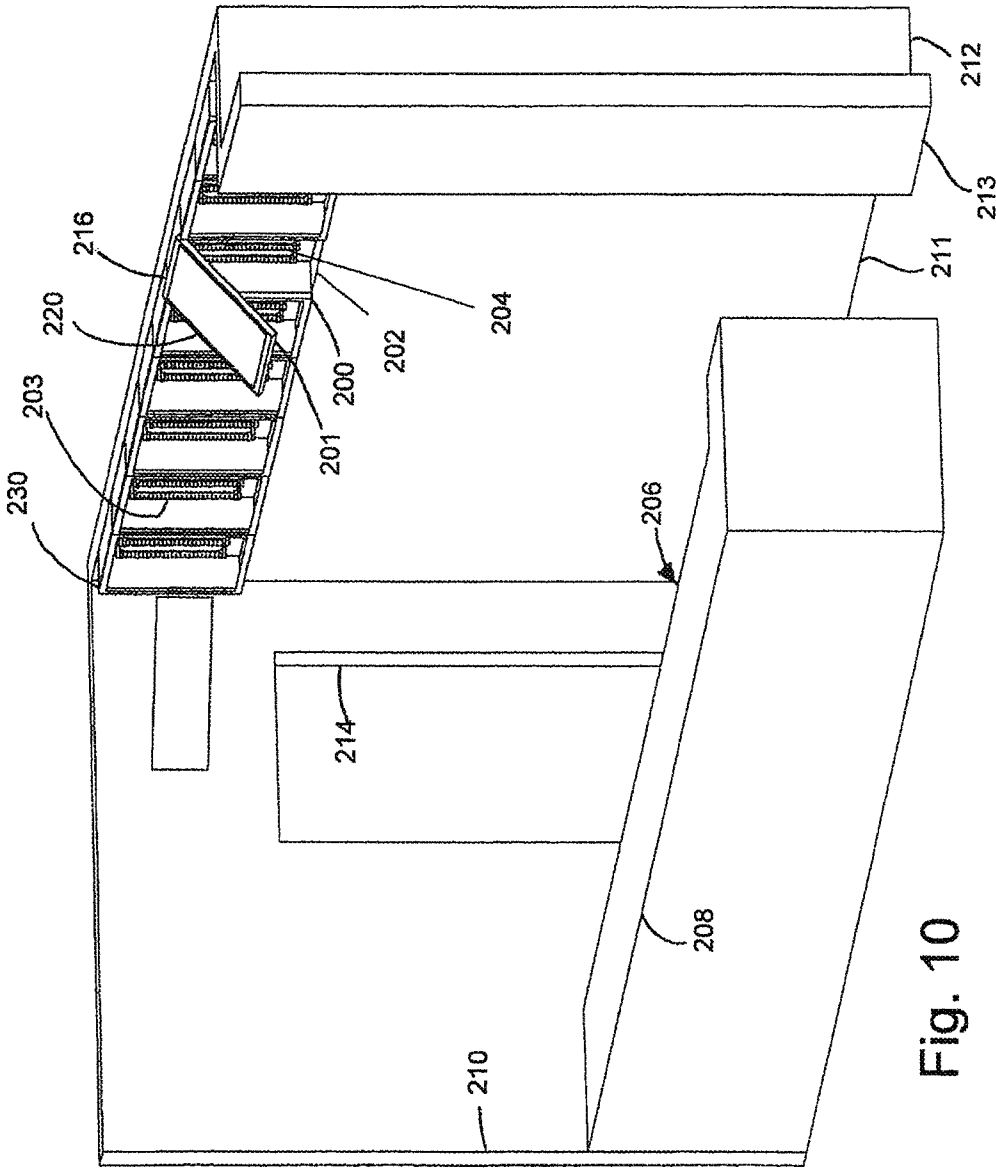

Fig. 10

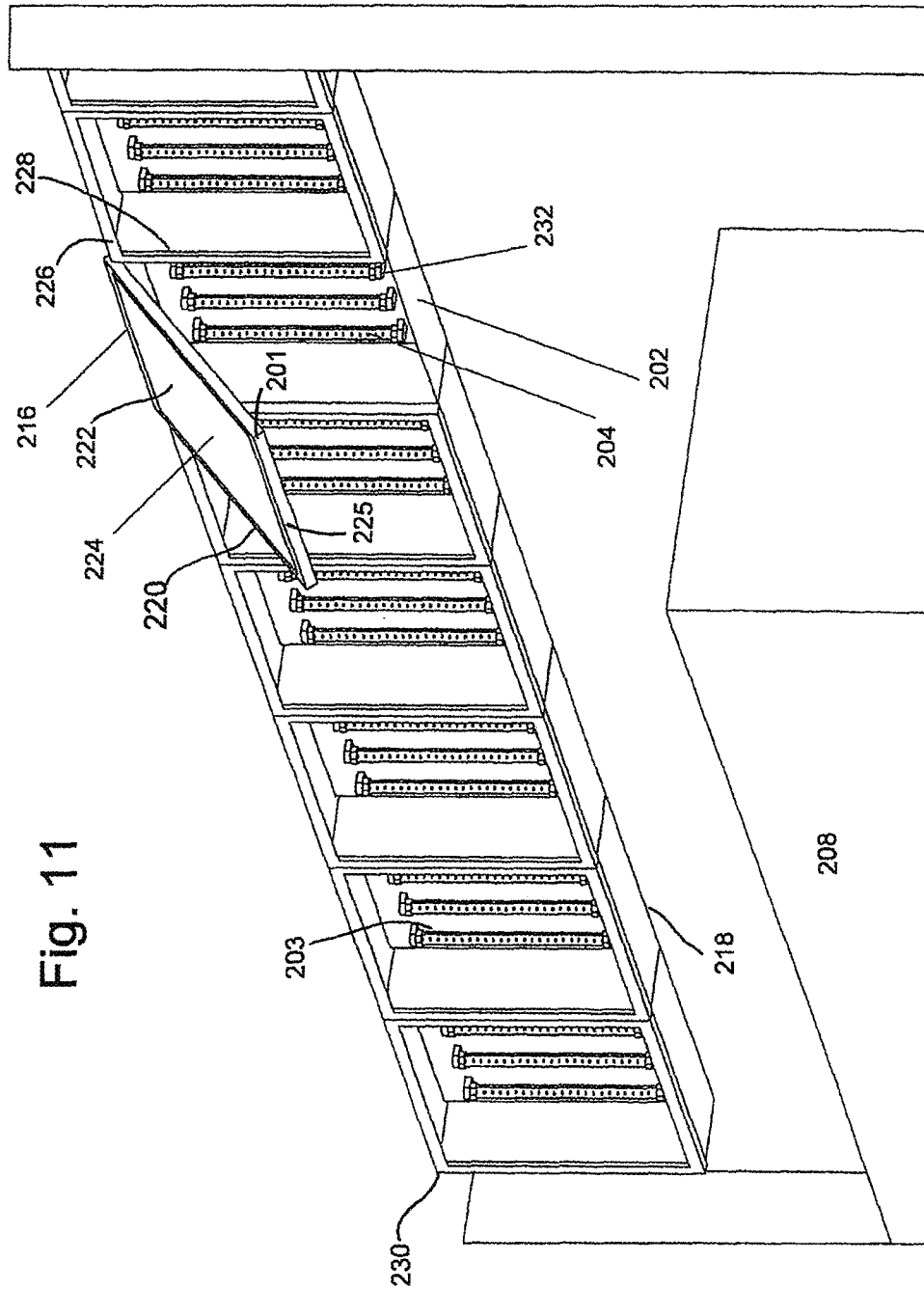

Fig. 11

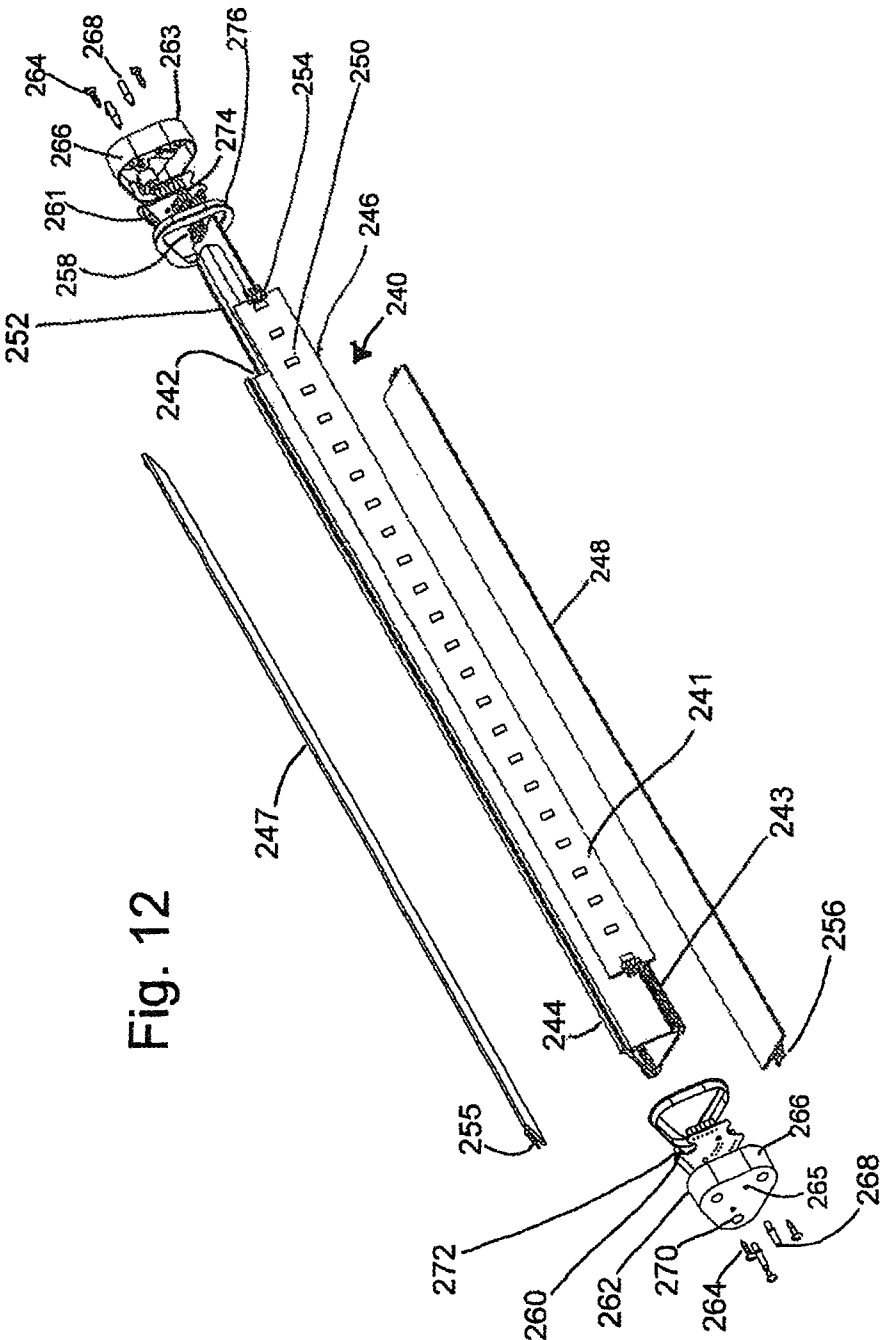
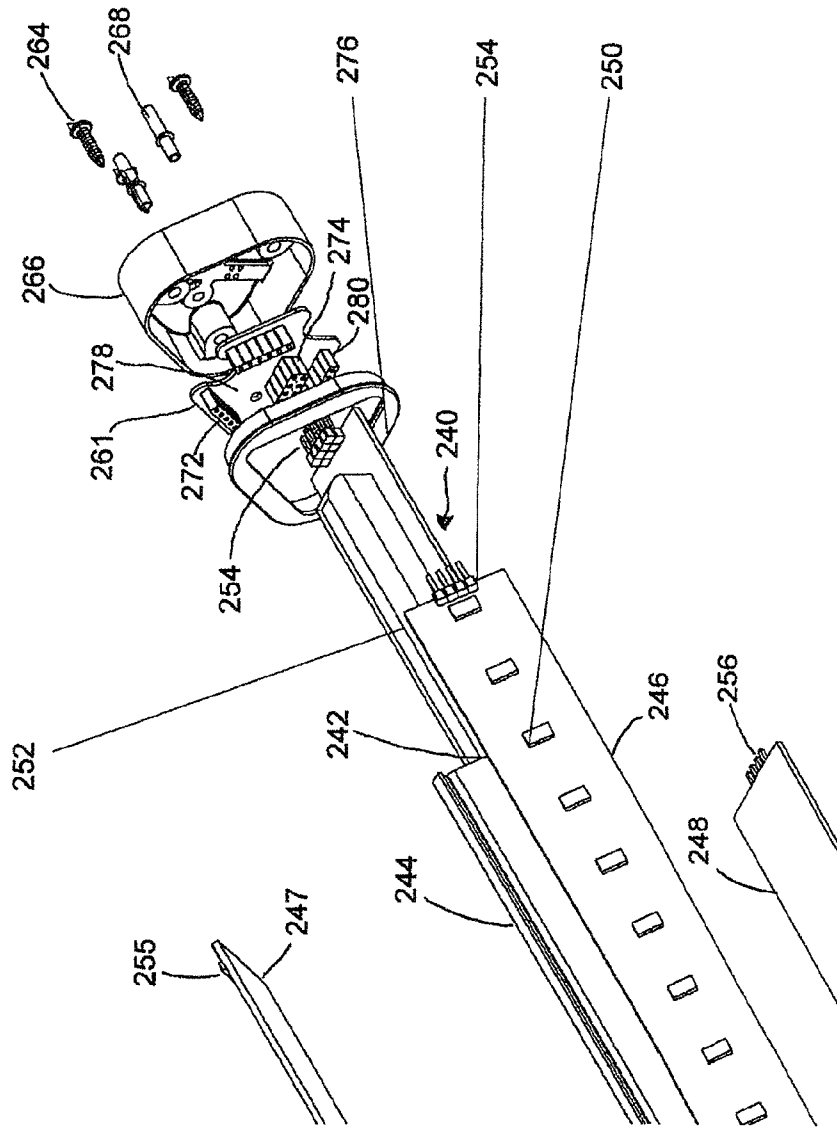
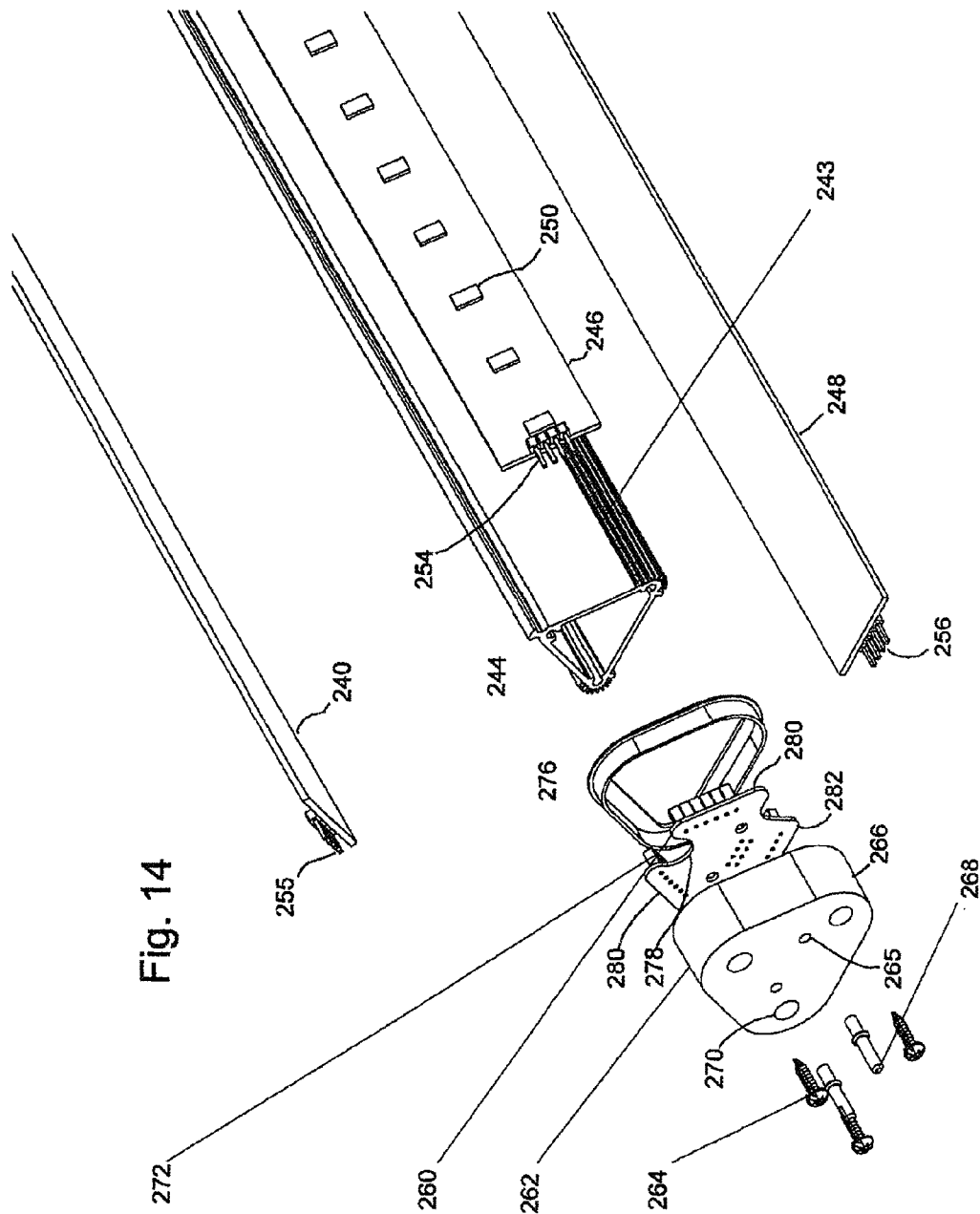

Fig. 12

Fig. 13





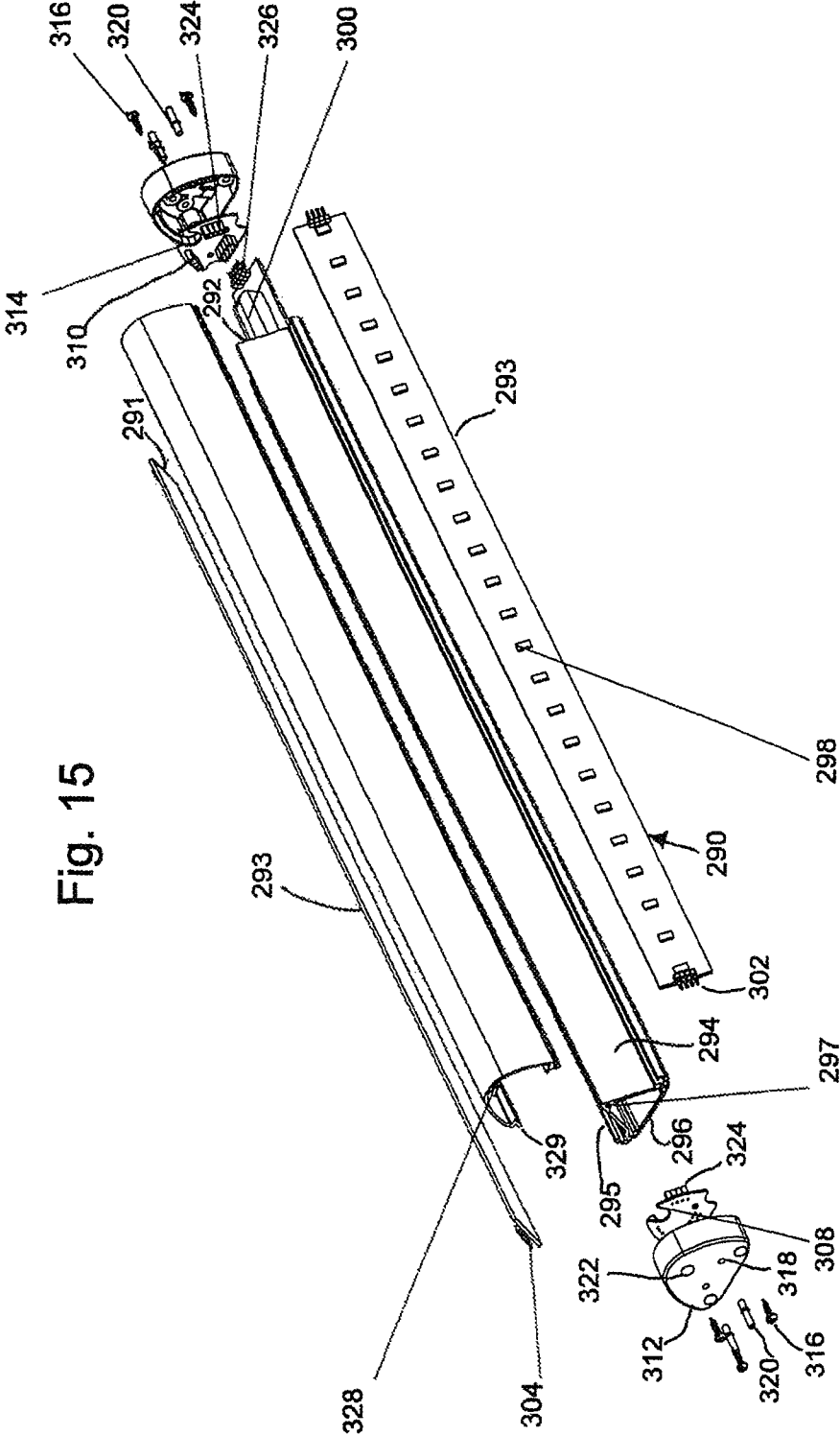

Fig. 15

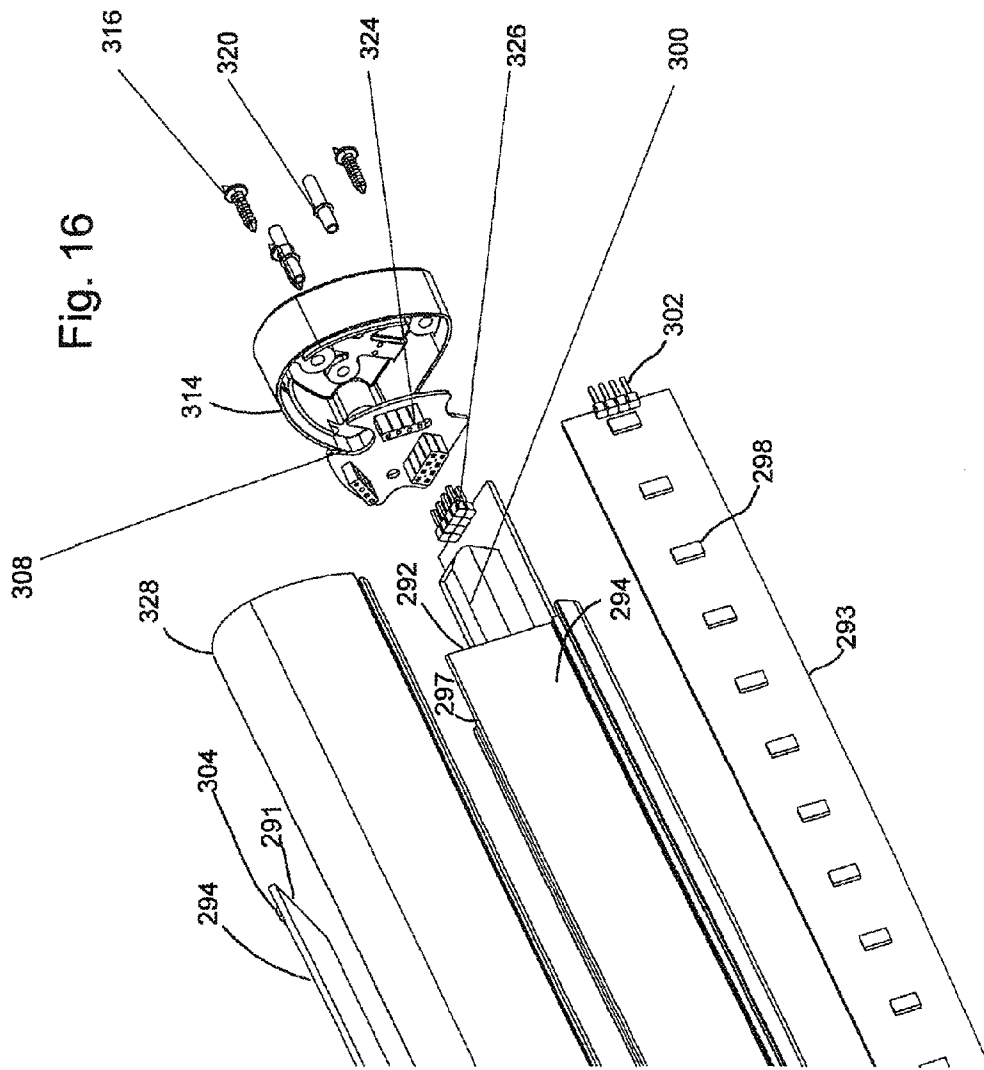

Fig. 17

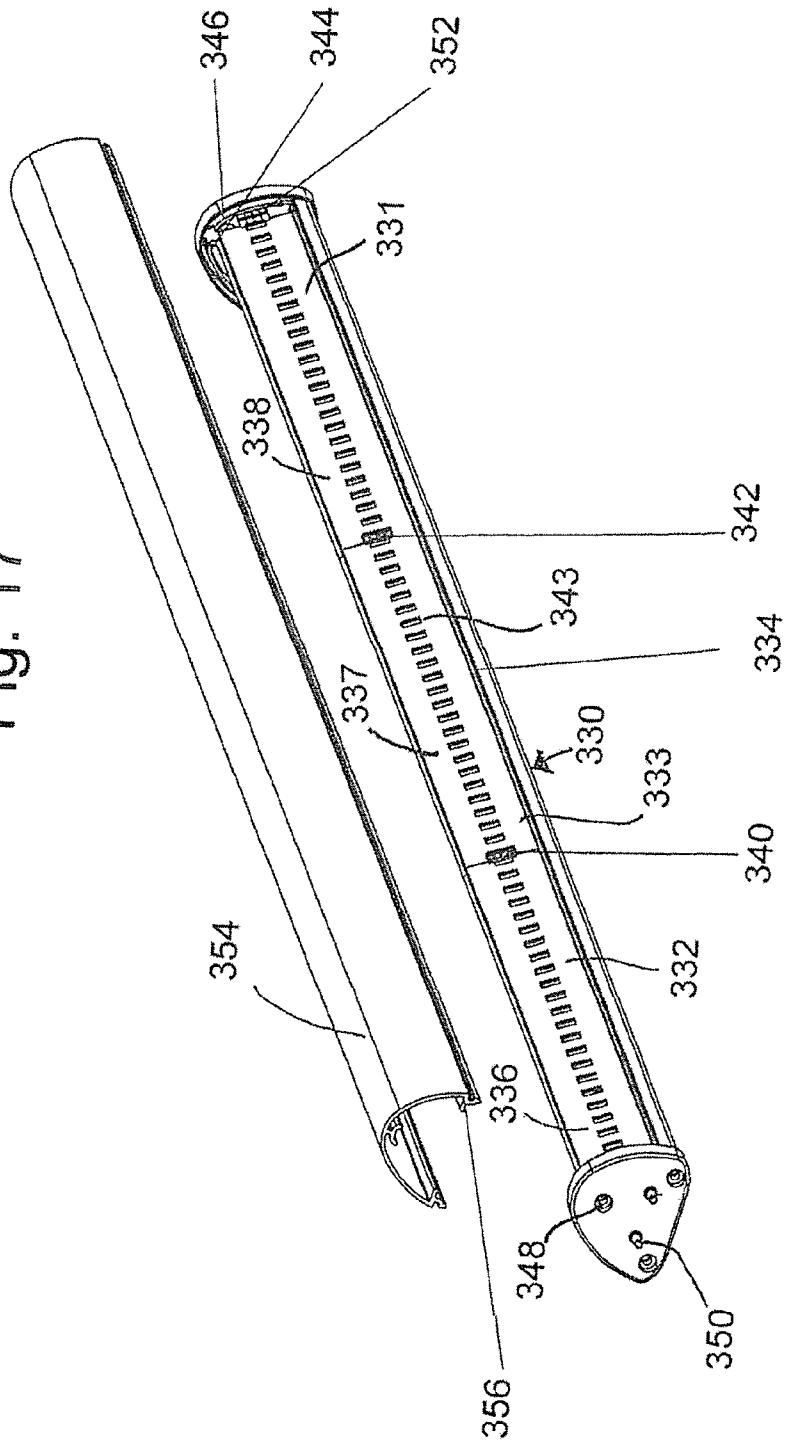
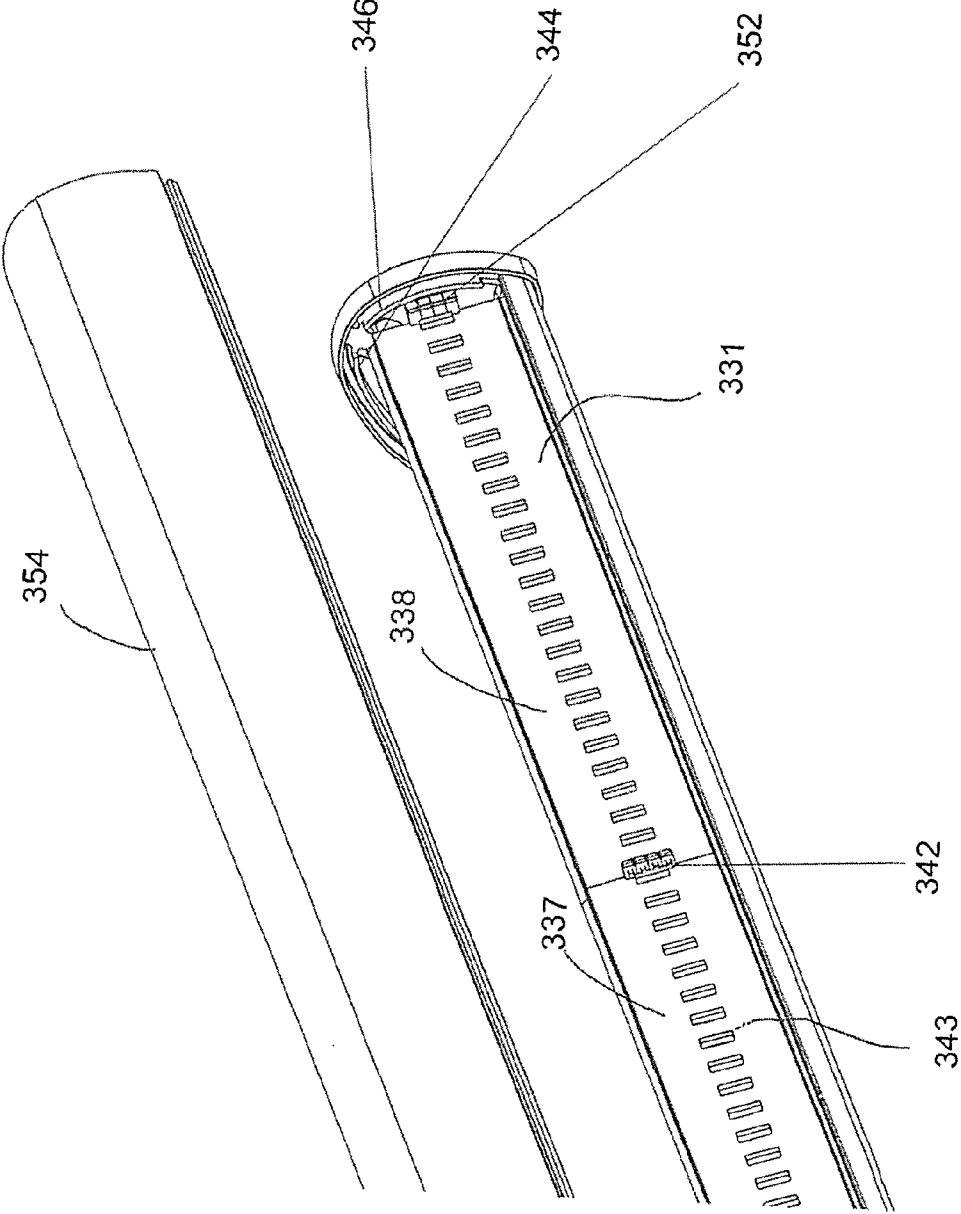

Fig. 18



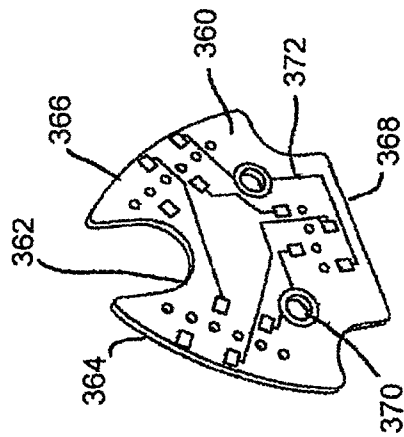

Fig. 19

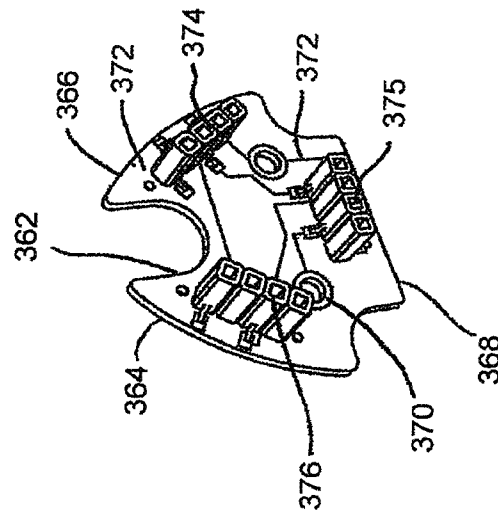

Fig. 20

Fig. 21

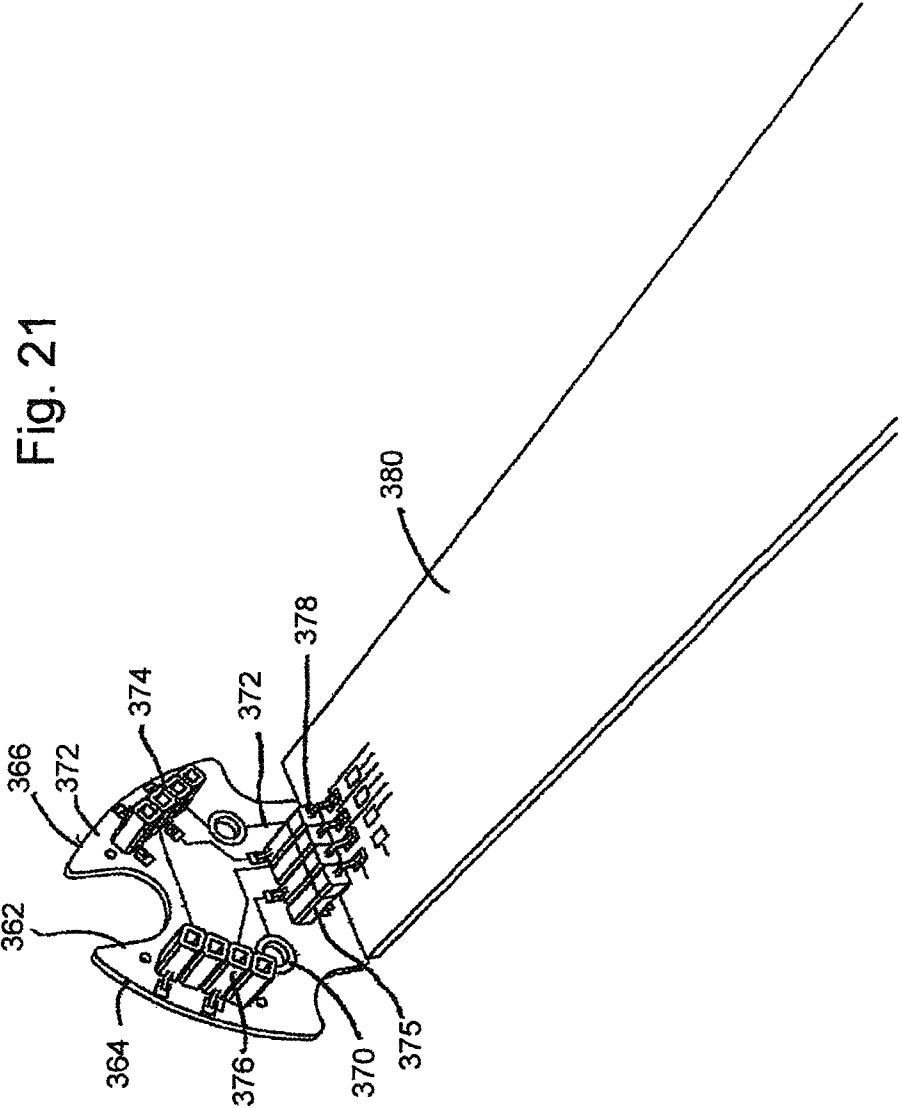
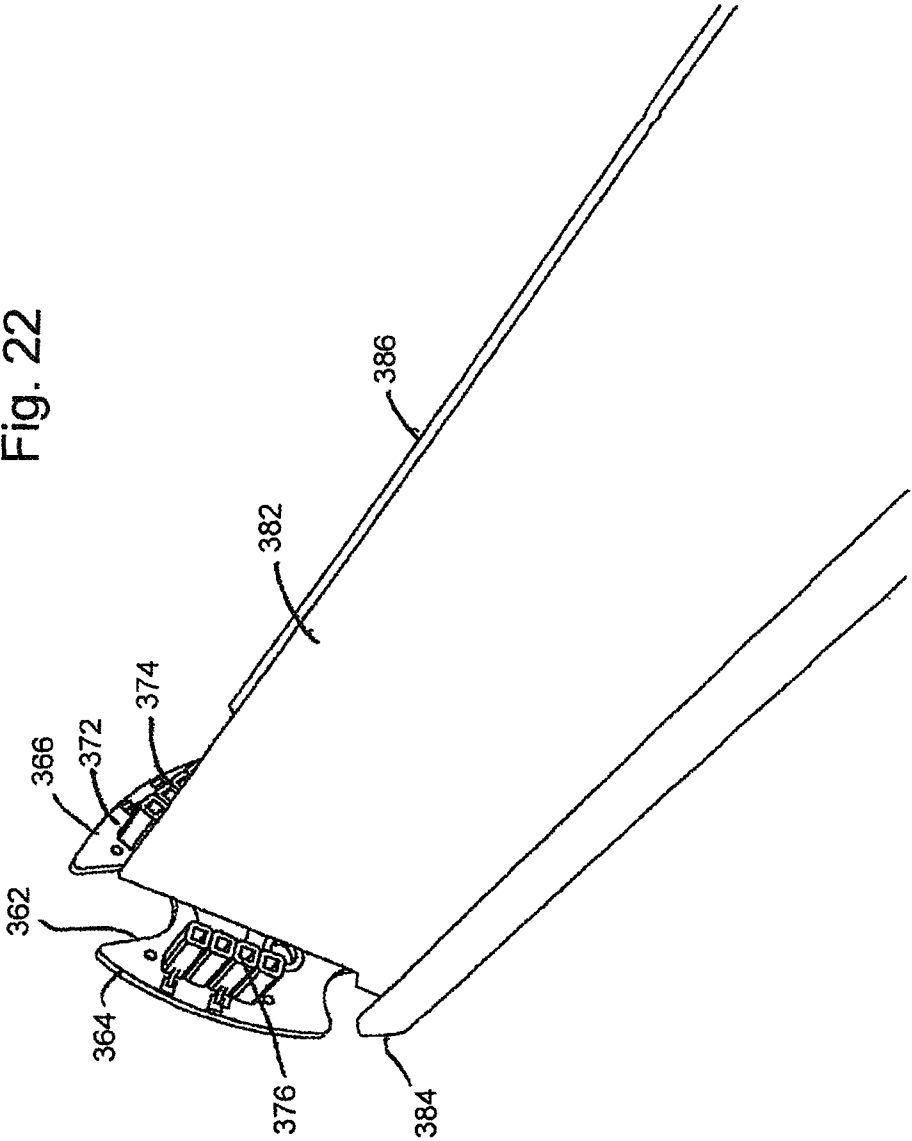

Fig. 22



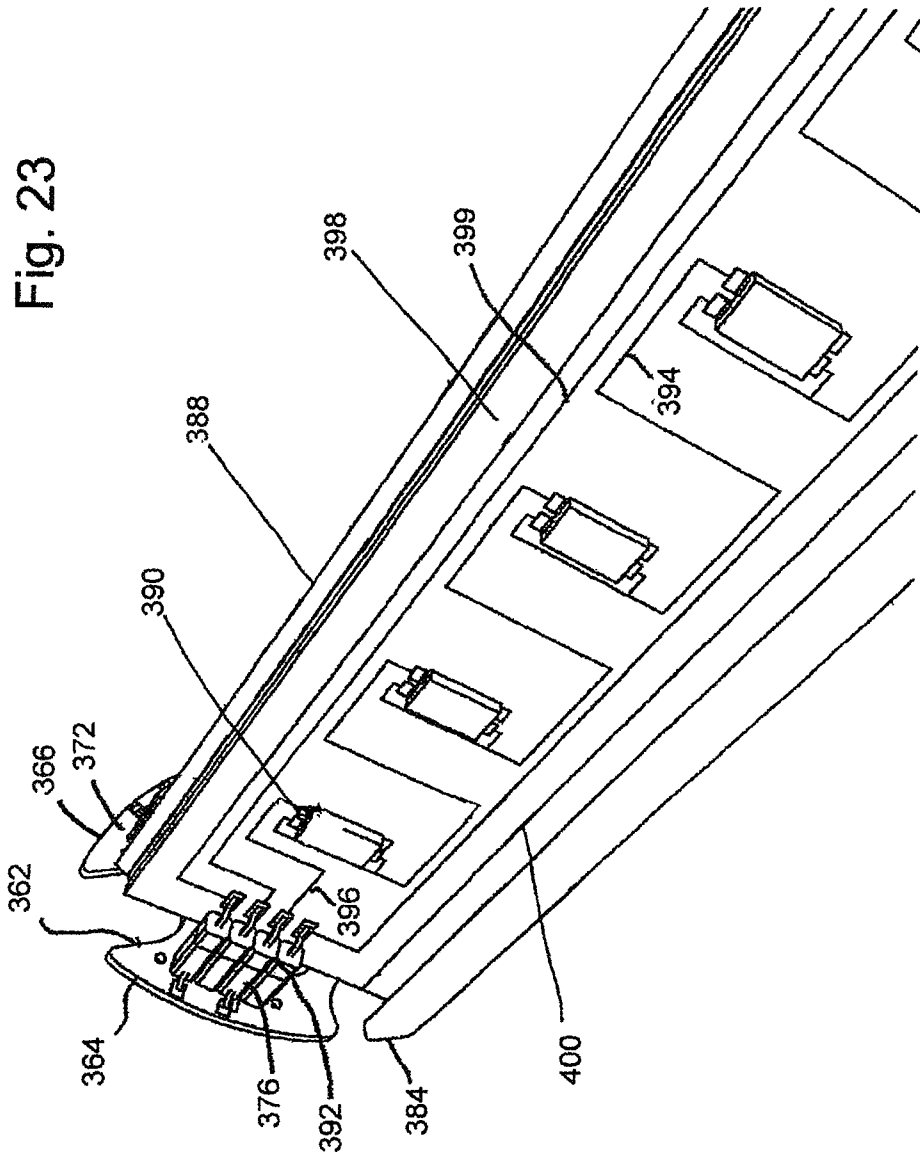

Fig. 24

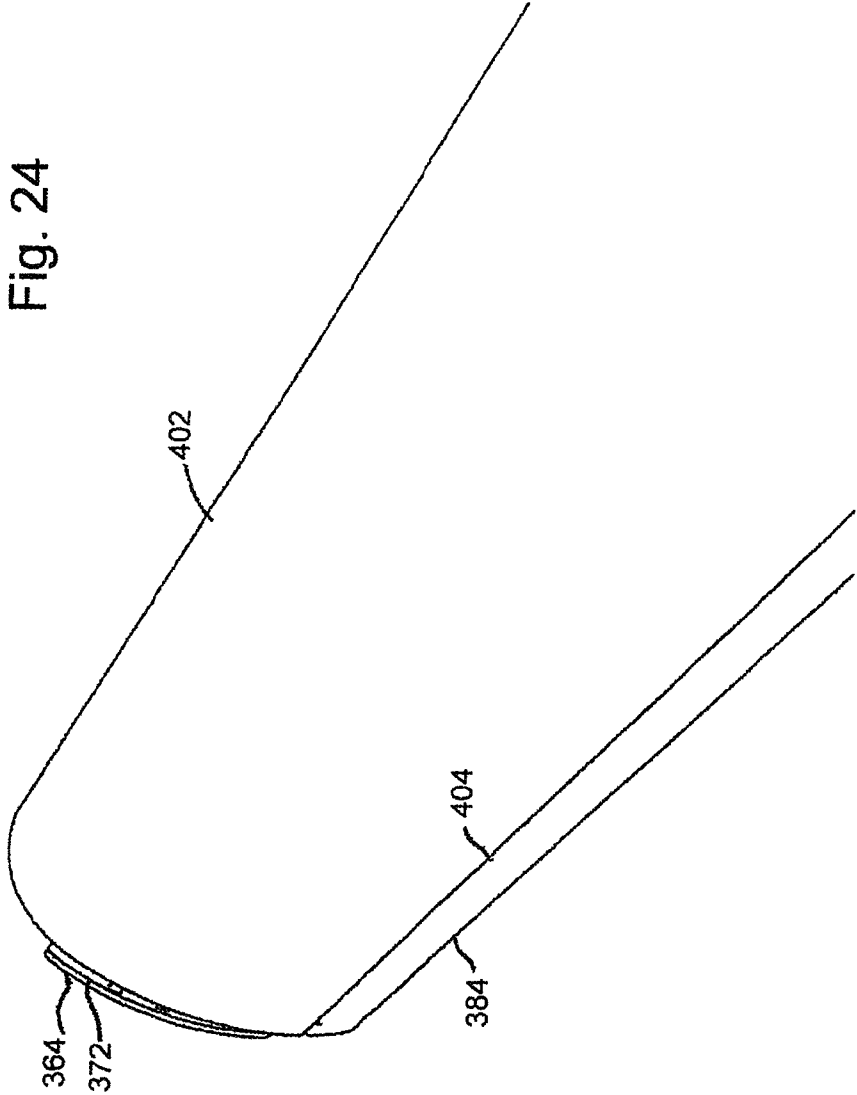

Fig. 25

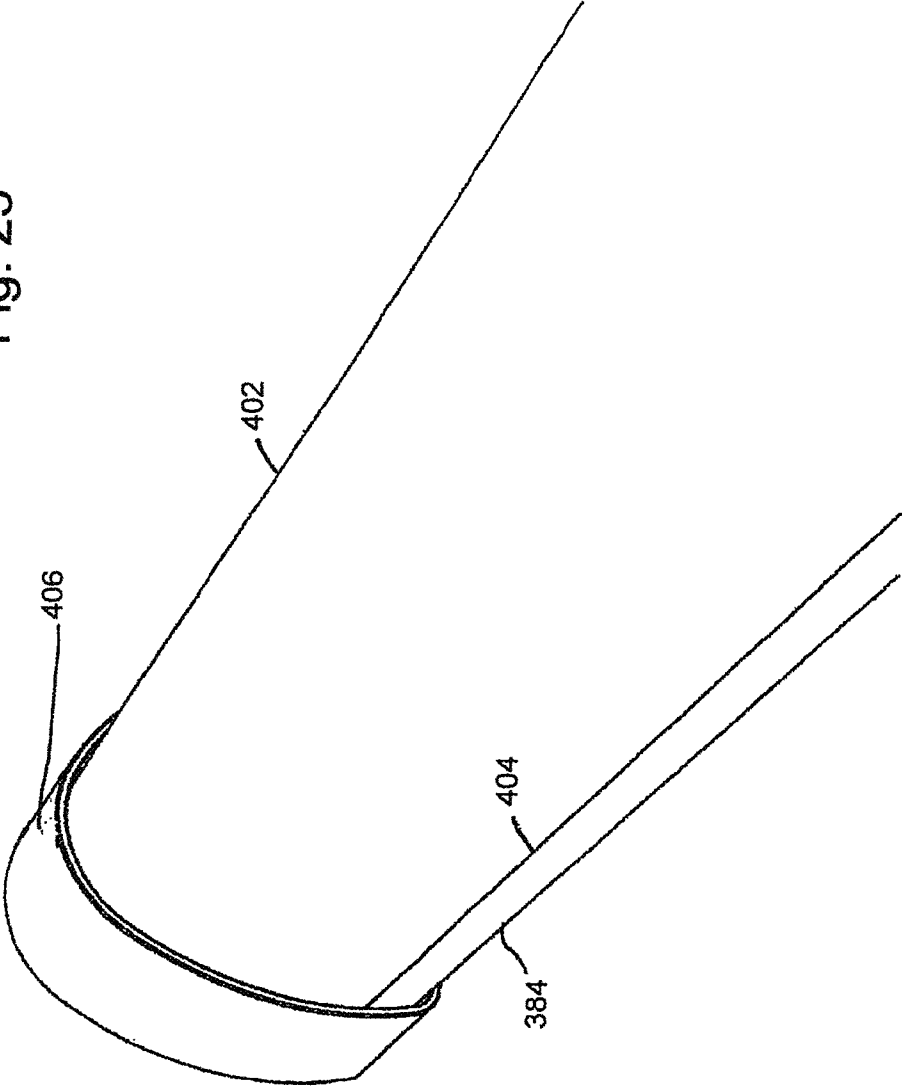

Fig. 26

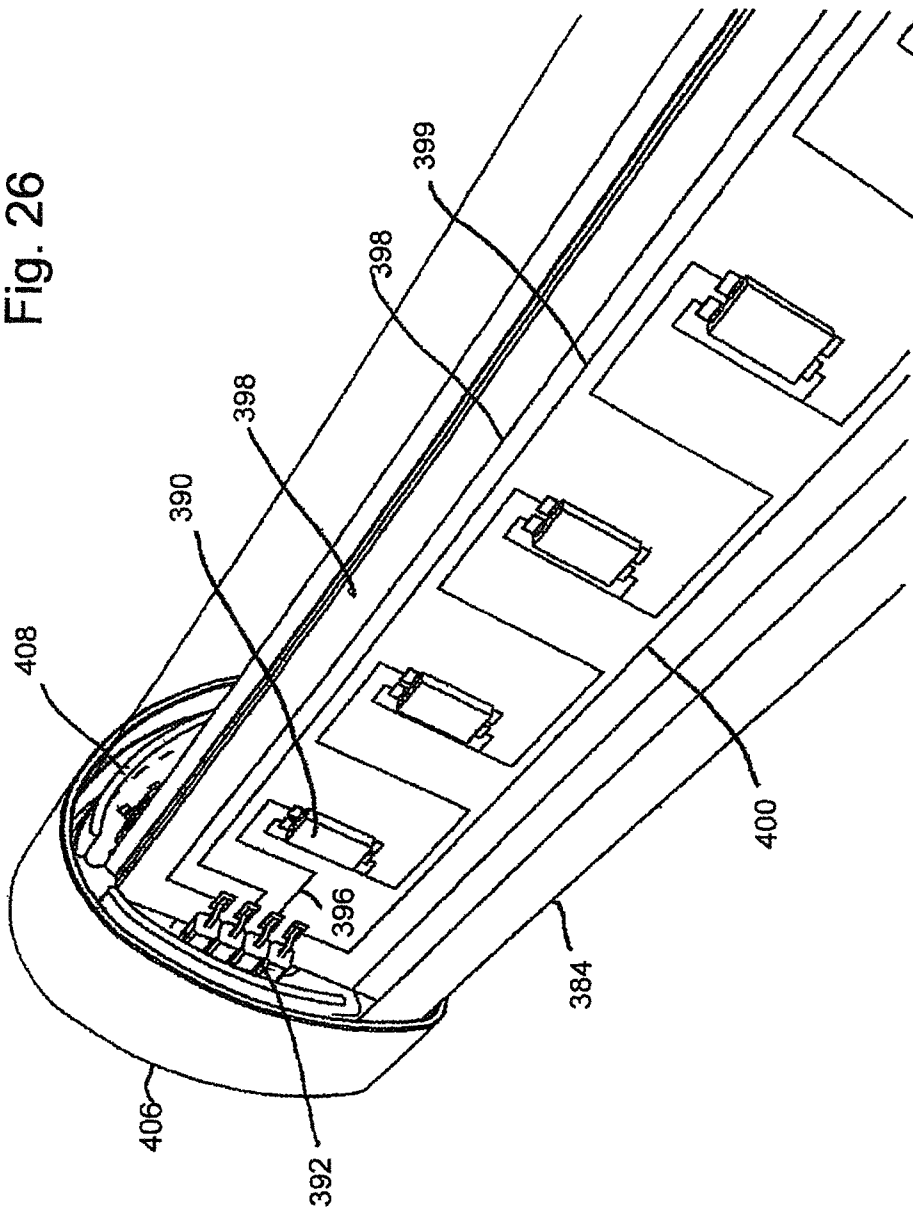
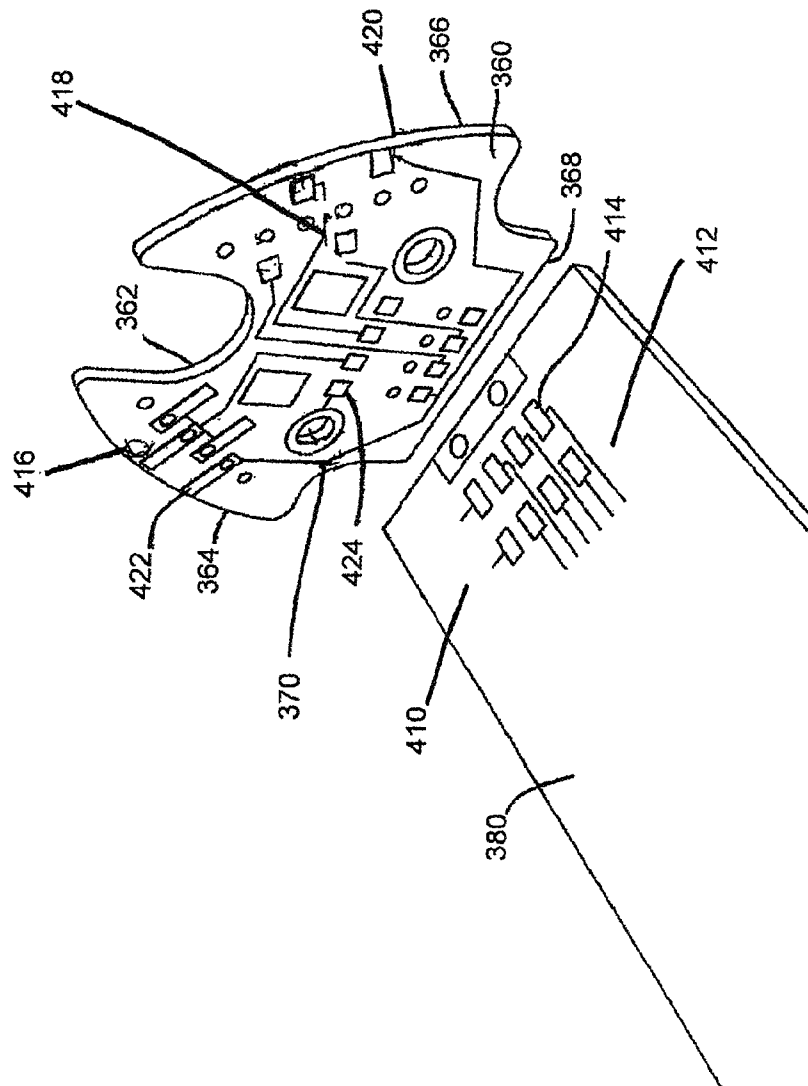

Fig. 27



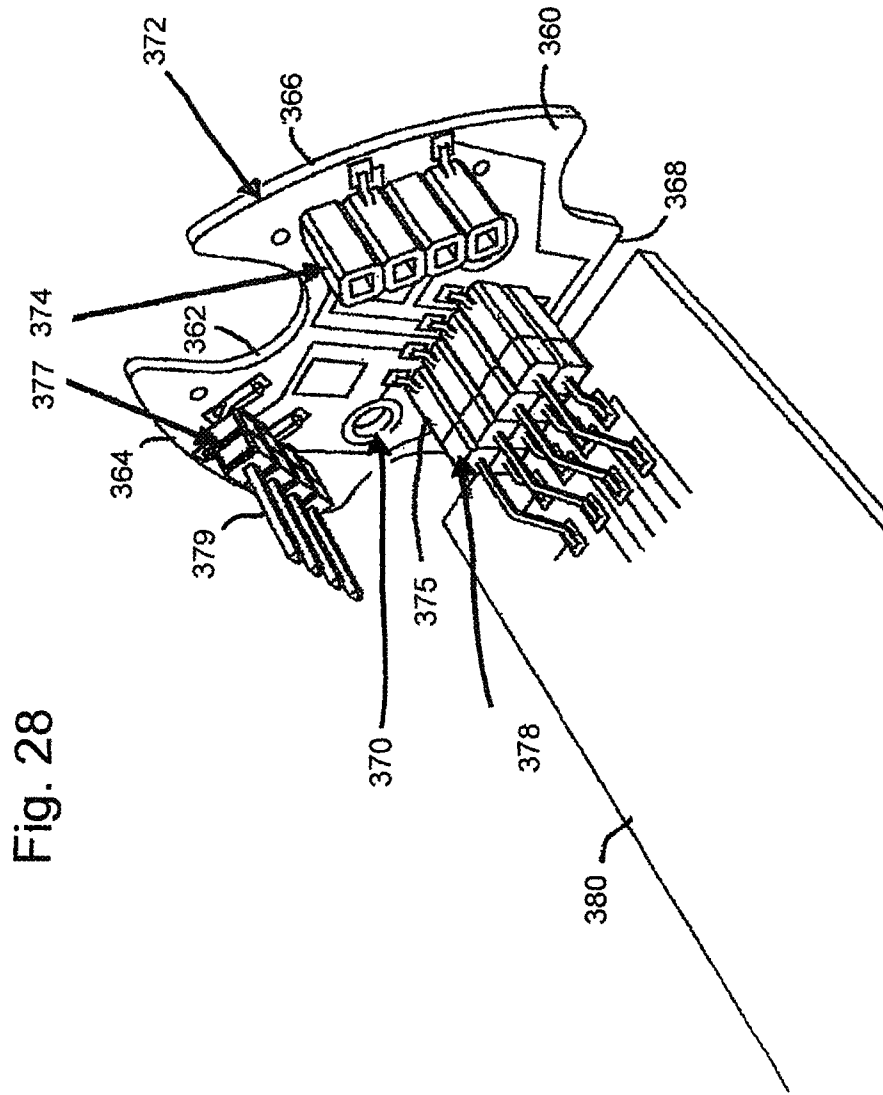

Fig. 28

Fig. 29

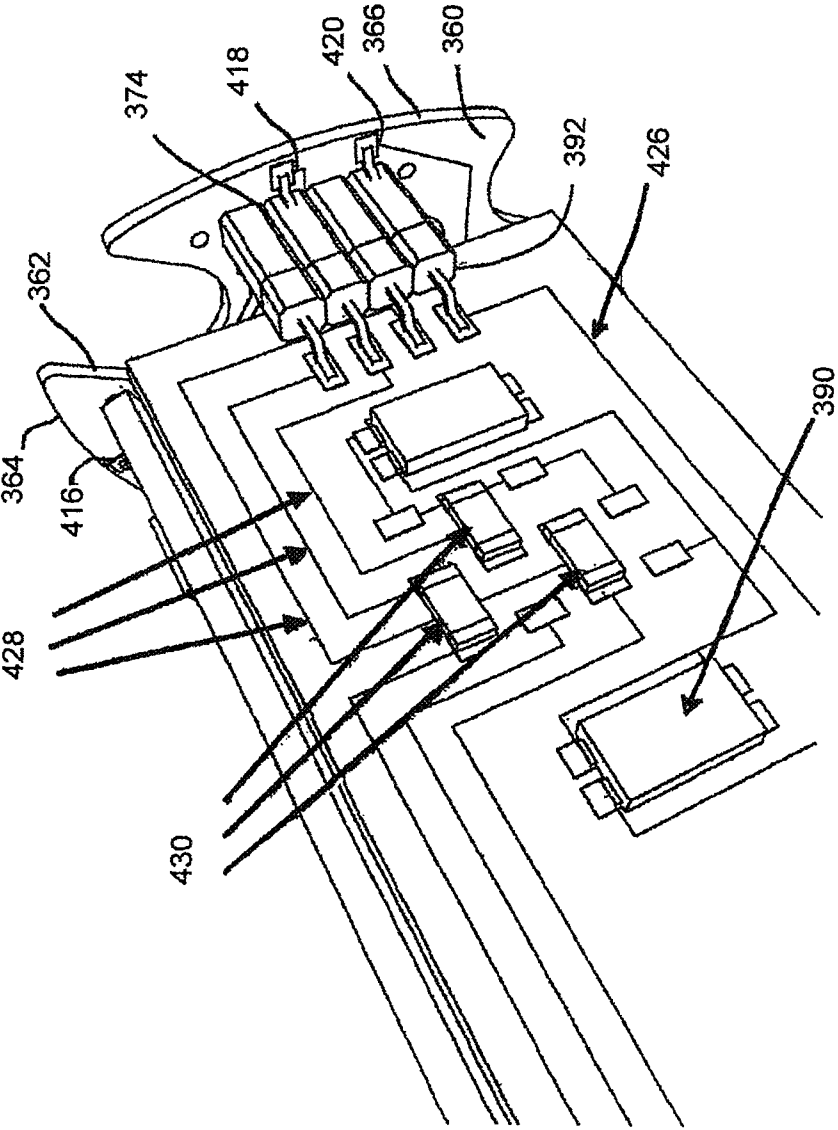

Fig. 30

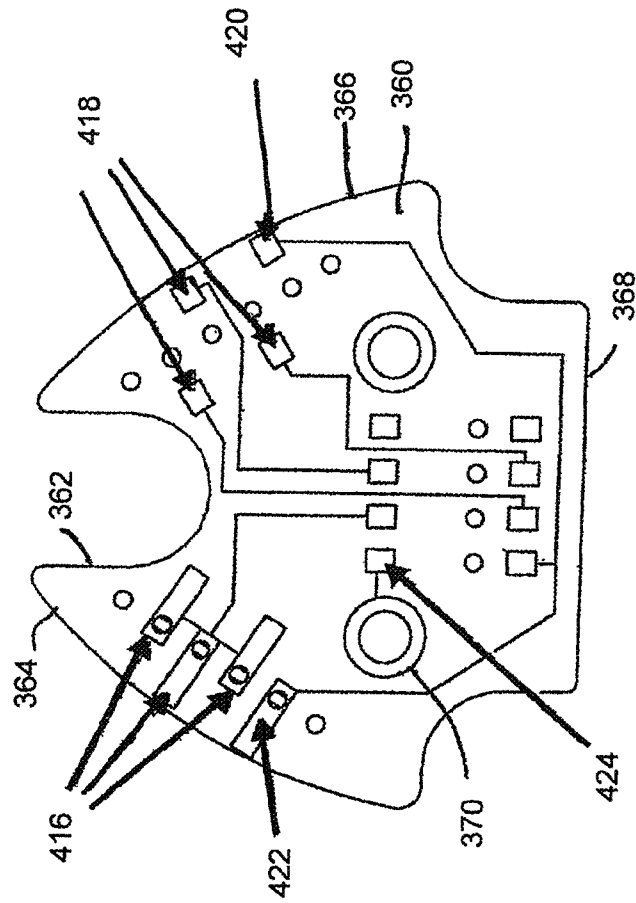

Fig. 31

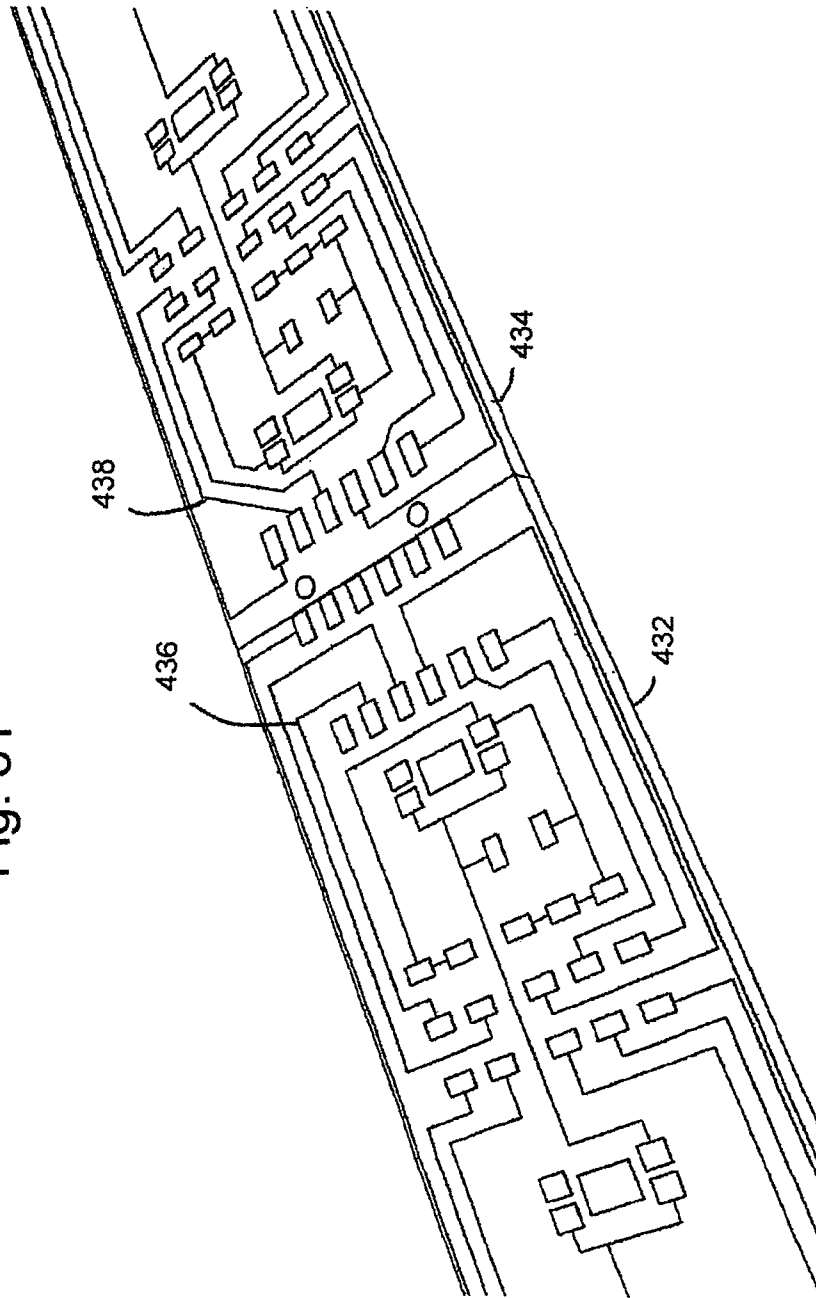

Fig. 32

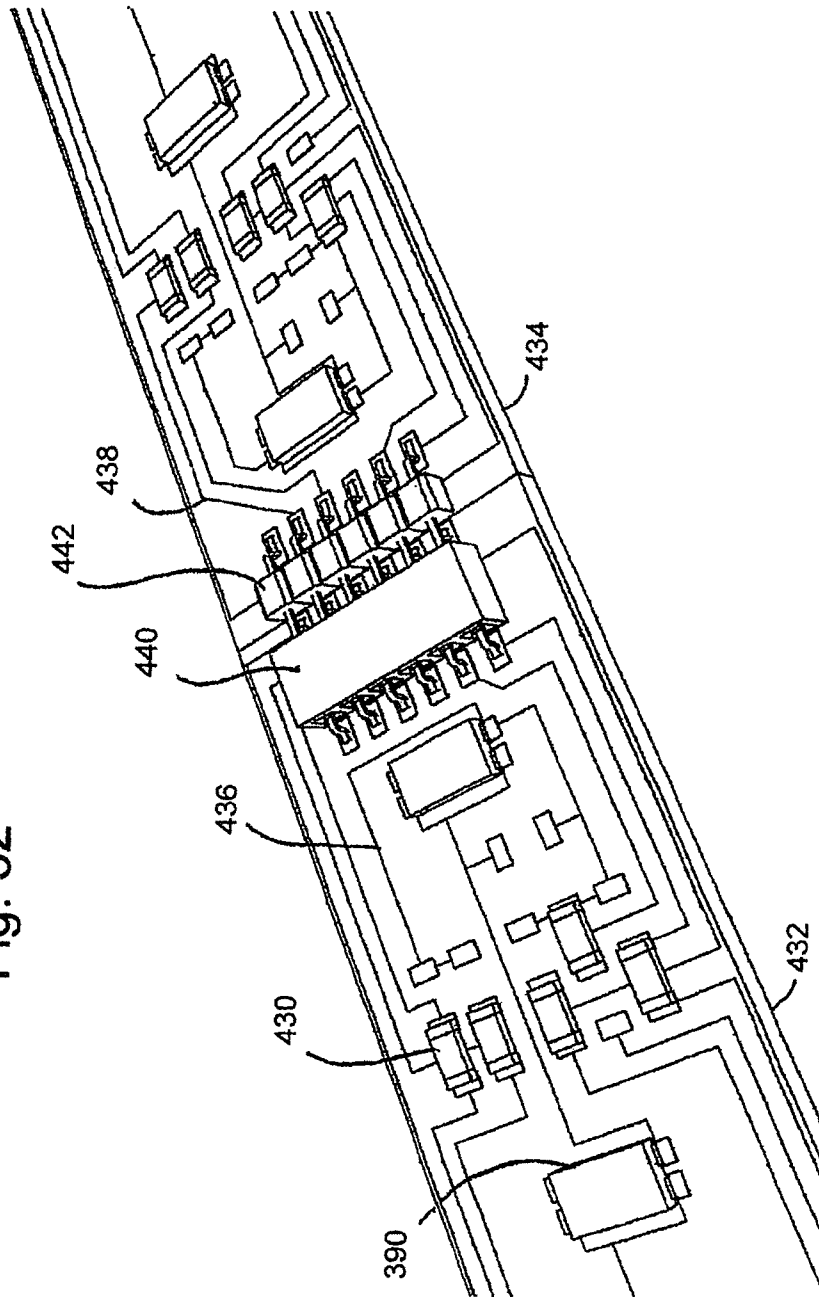
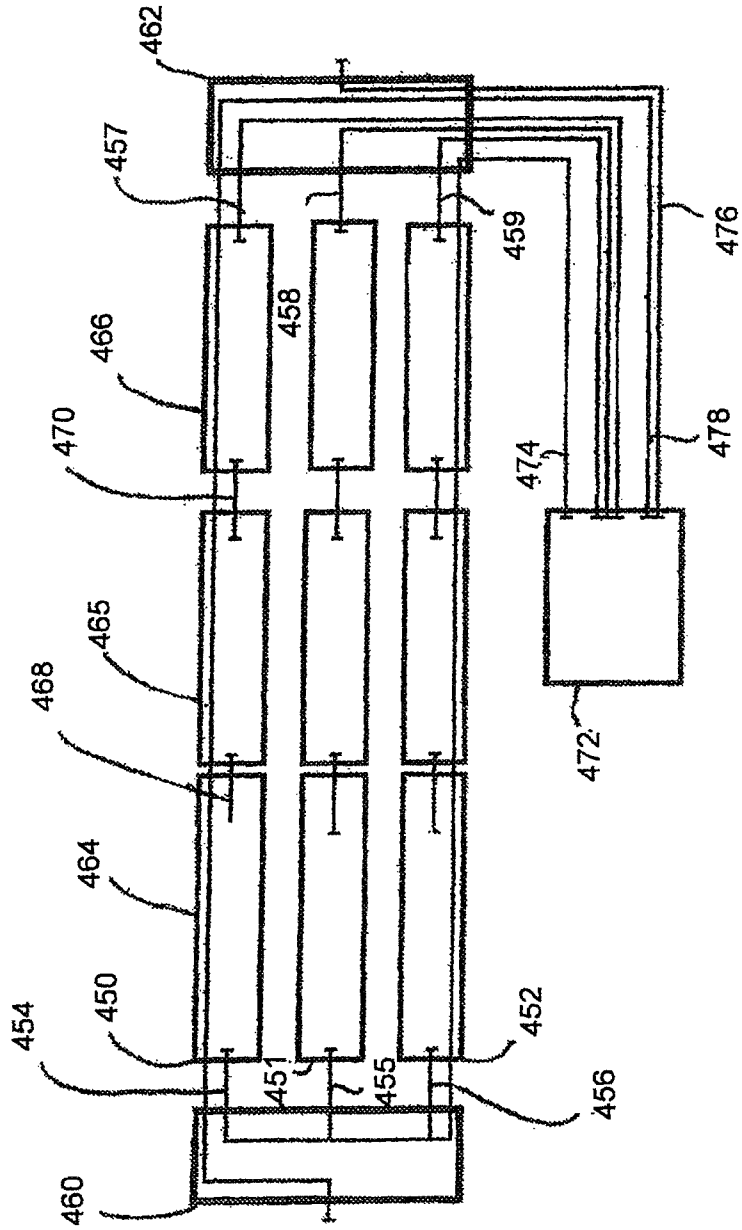

Fig. 33



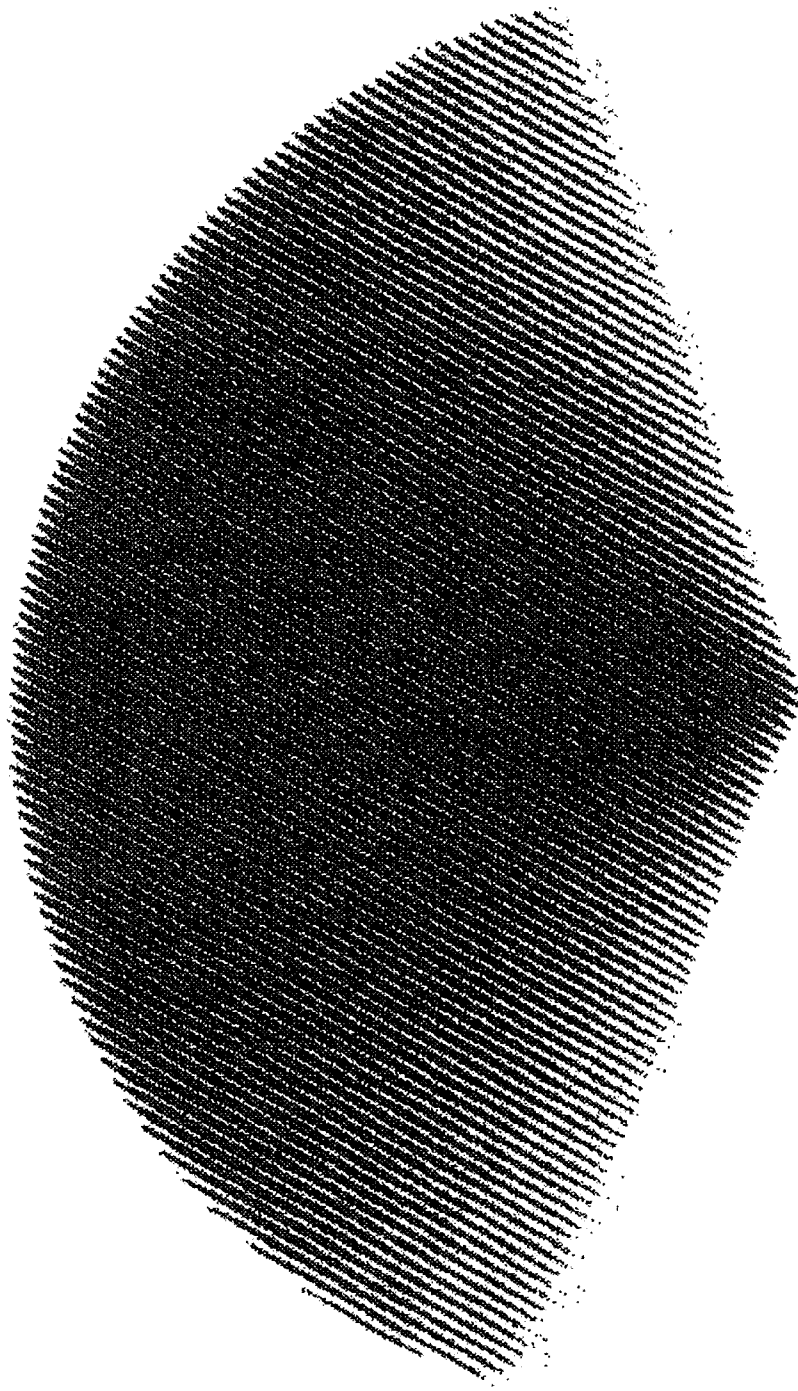

Fig. 34

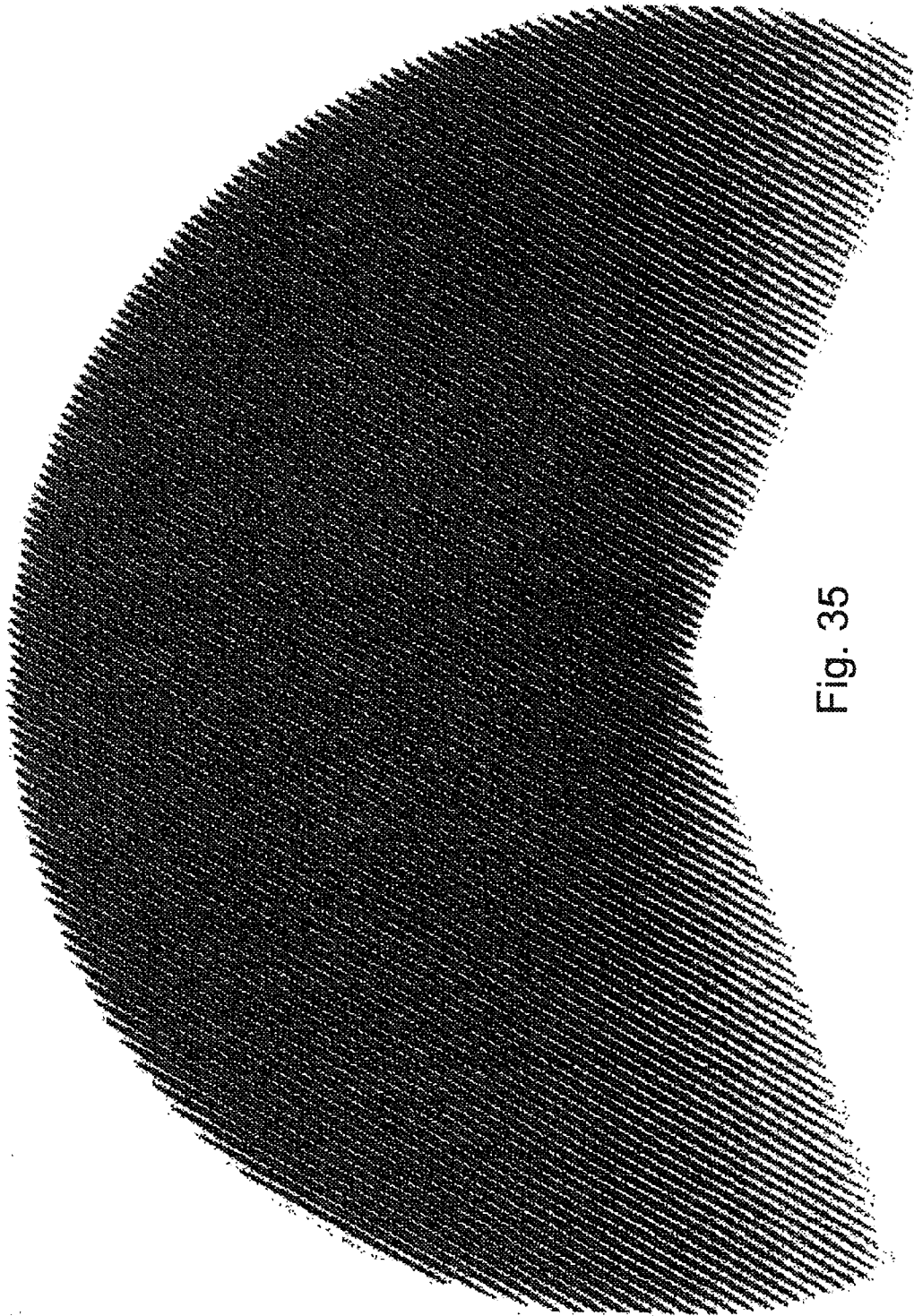

Fig. 35

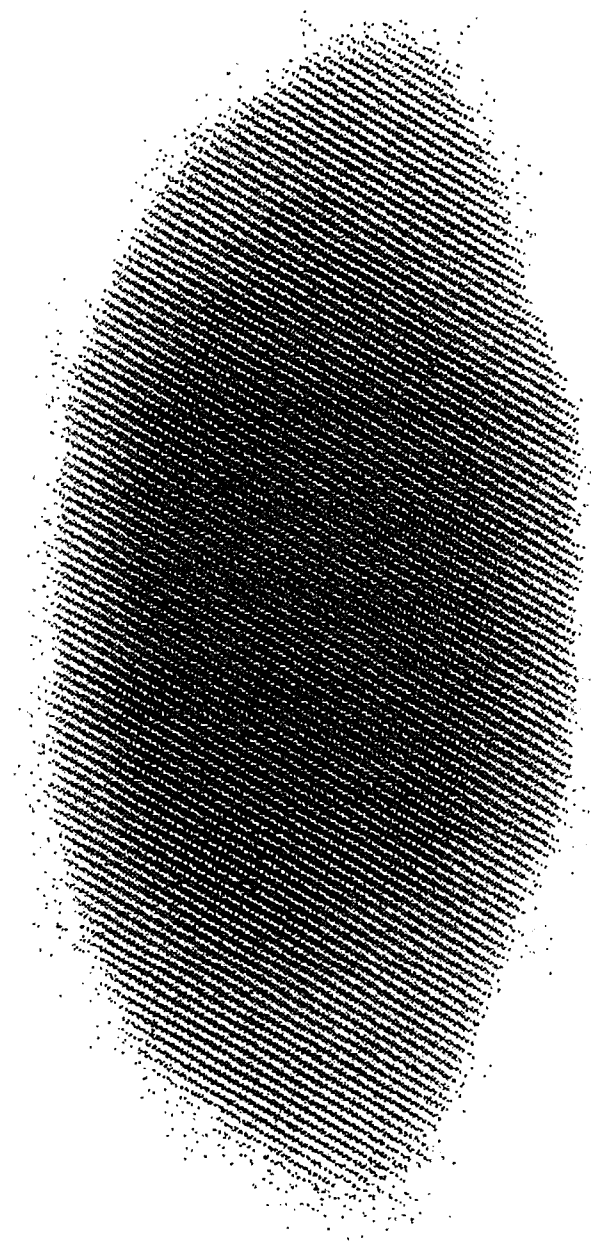

Fig. 36

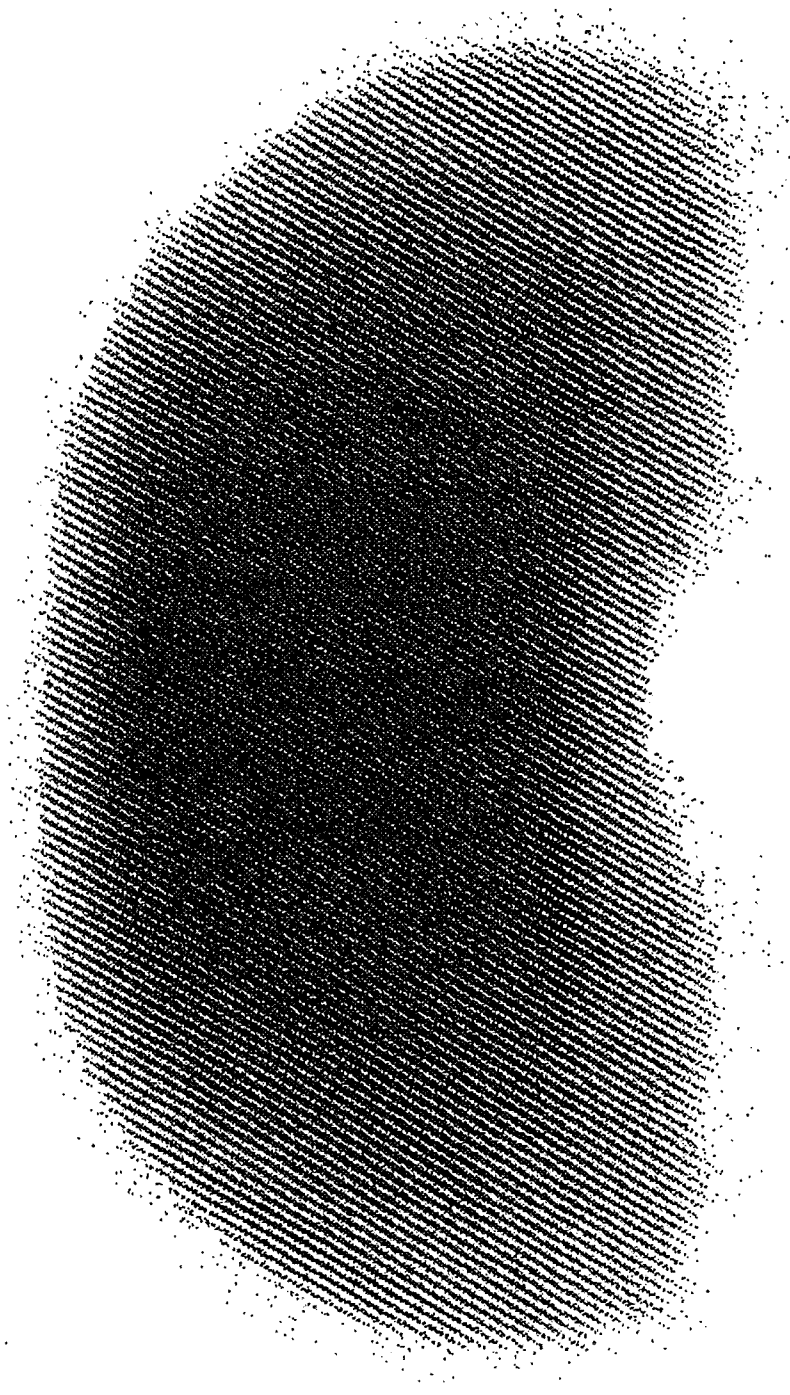

Fig. 37

Fig. 38

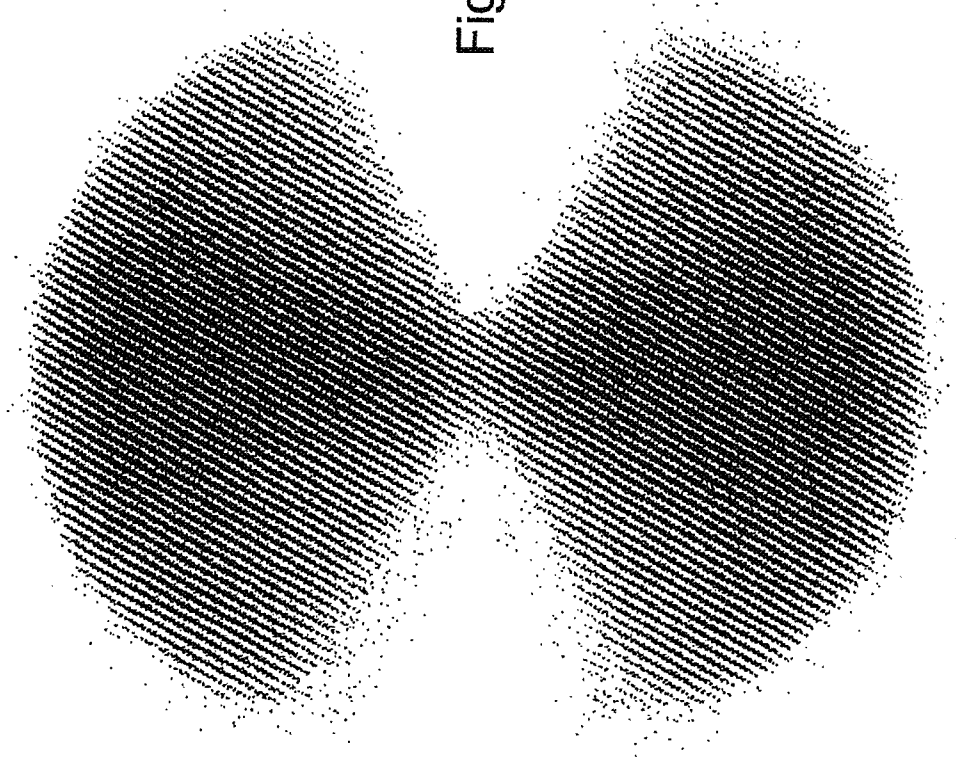
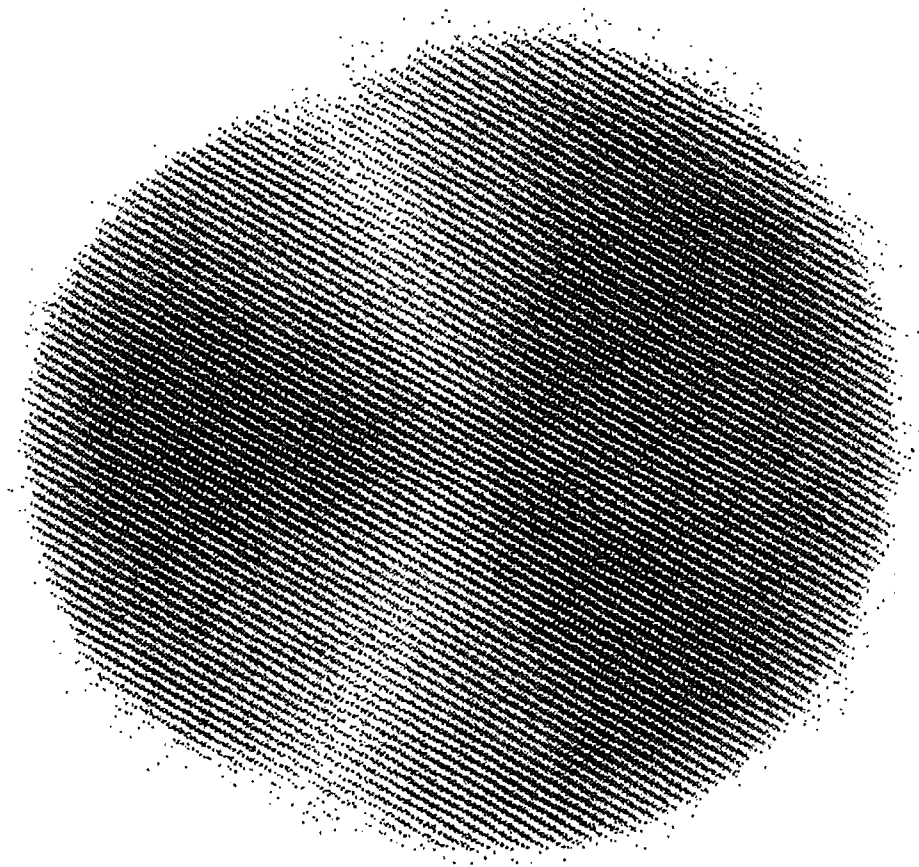

Fig. 39



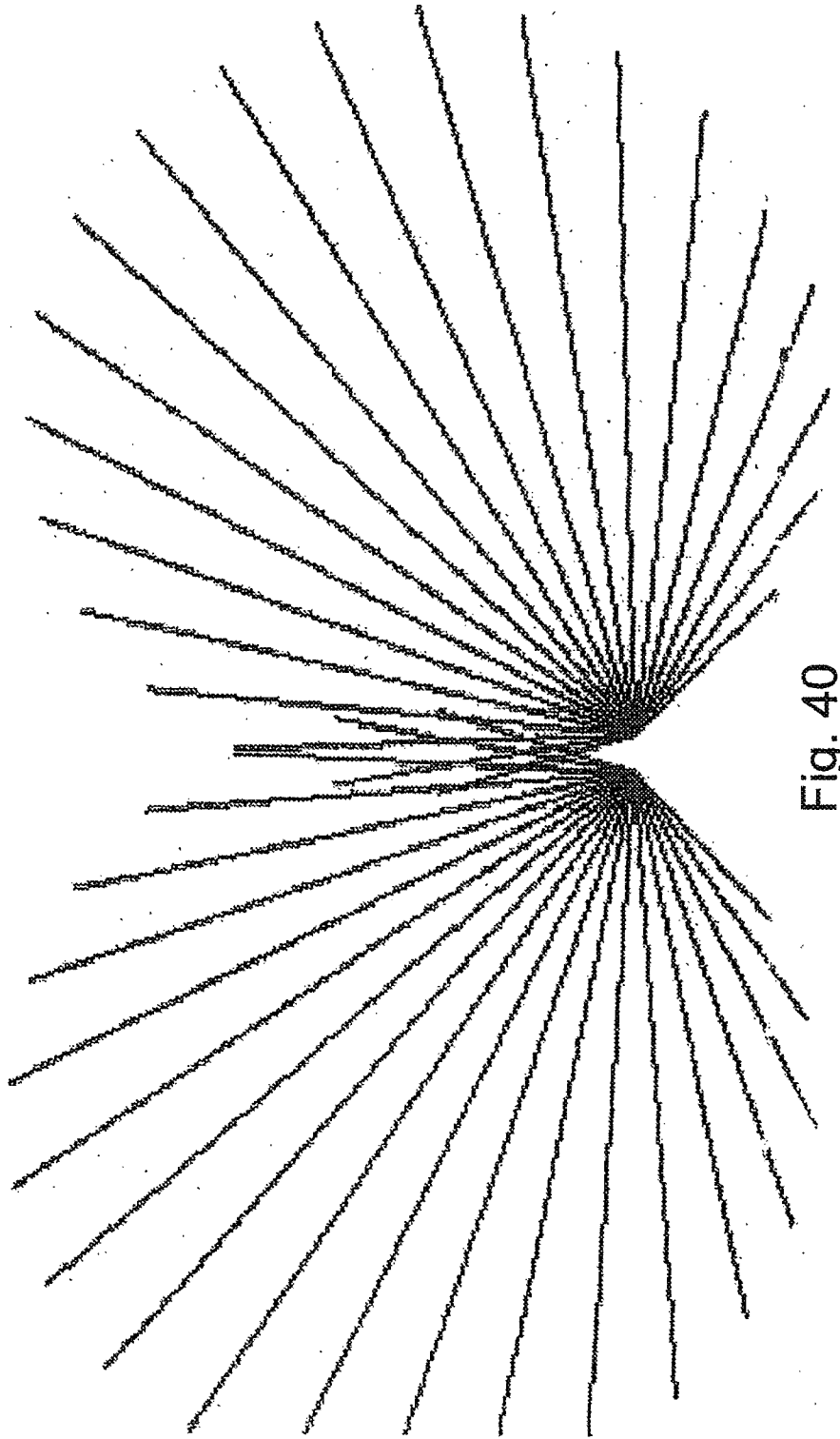

Fig. 40

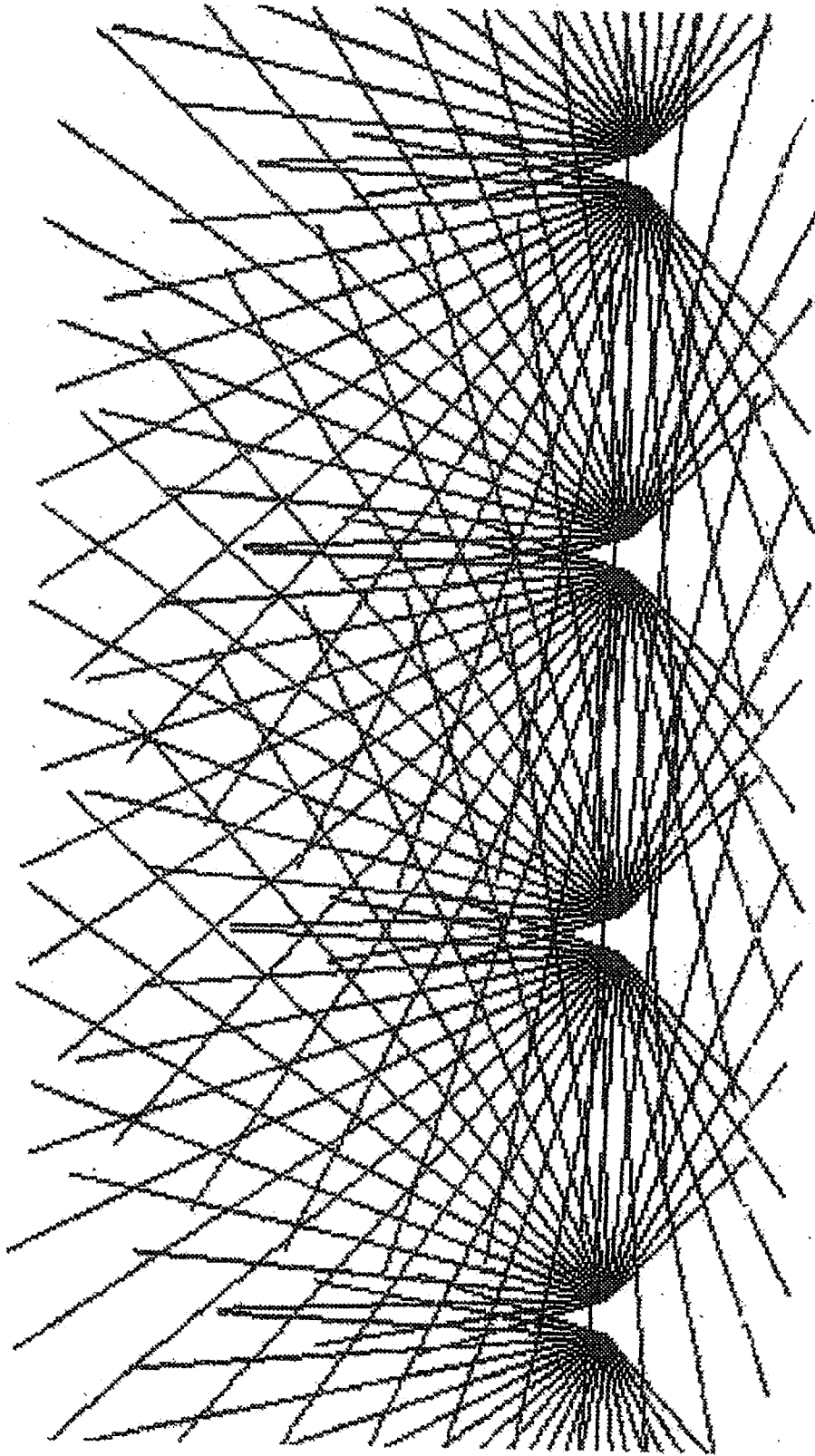

Fig. 41

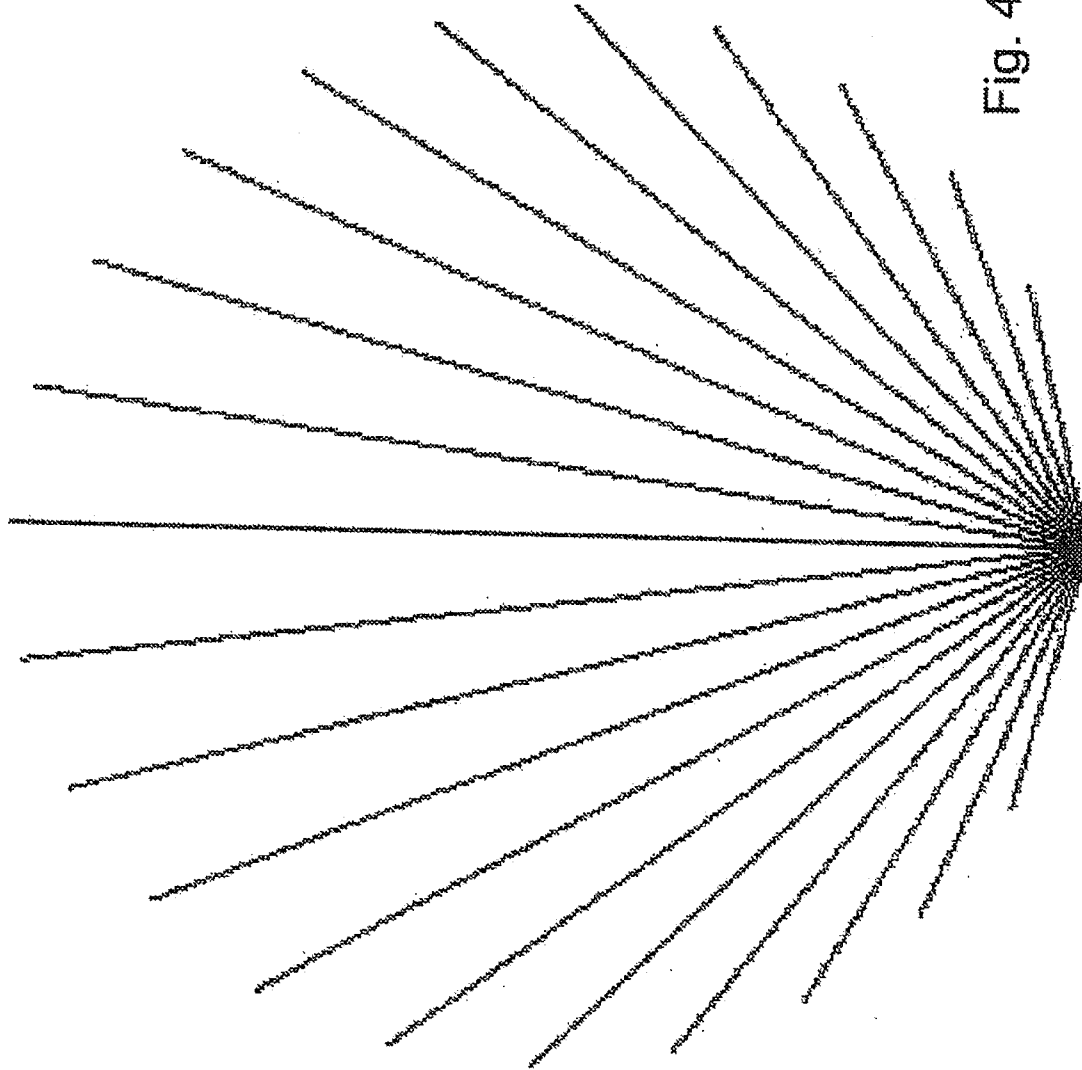
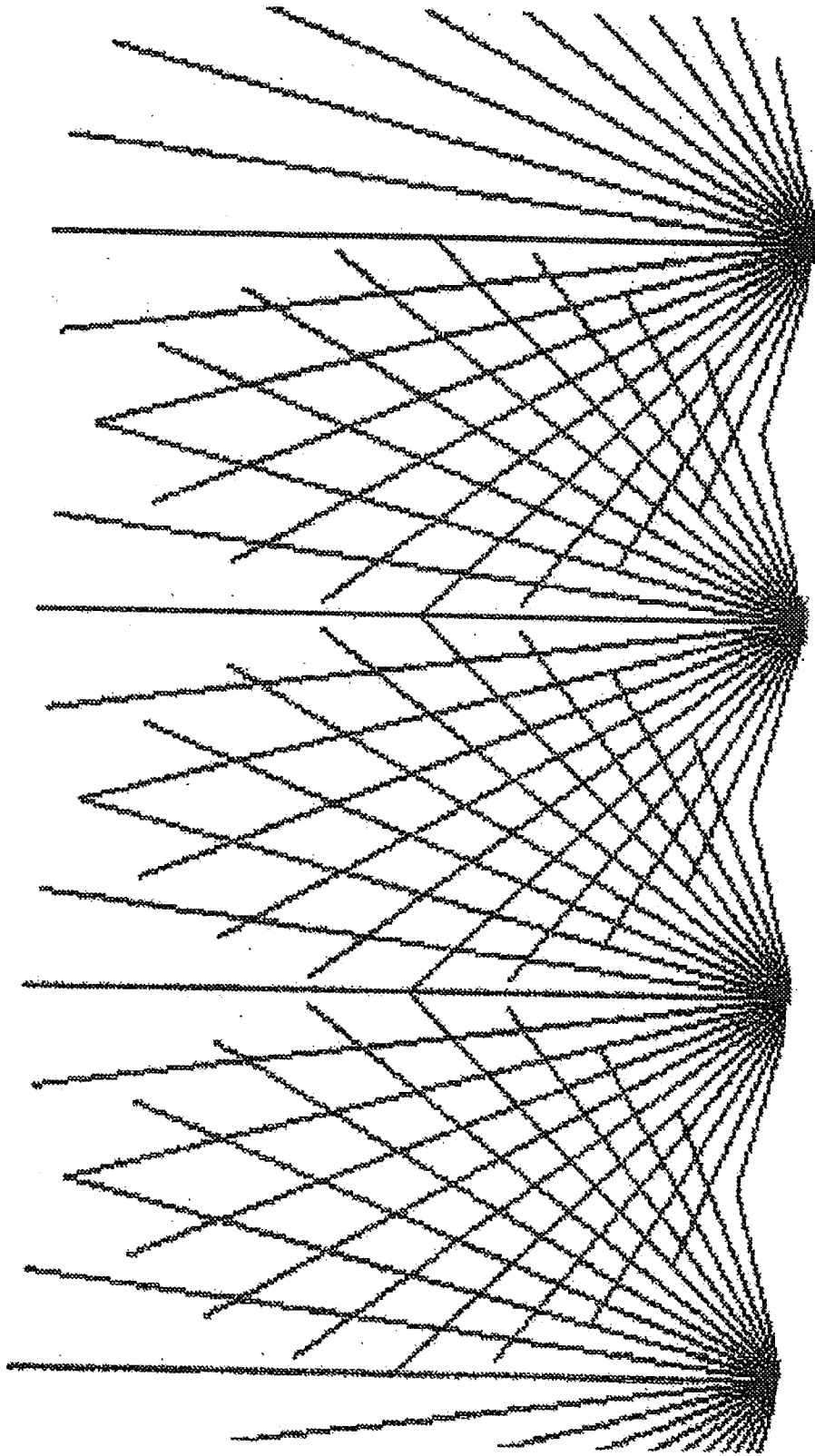

Fig. 42

Fig. 43



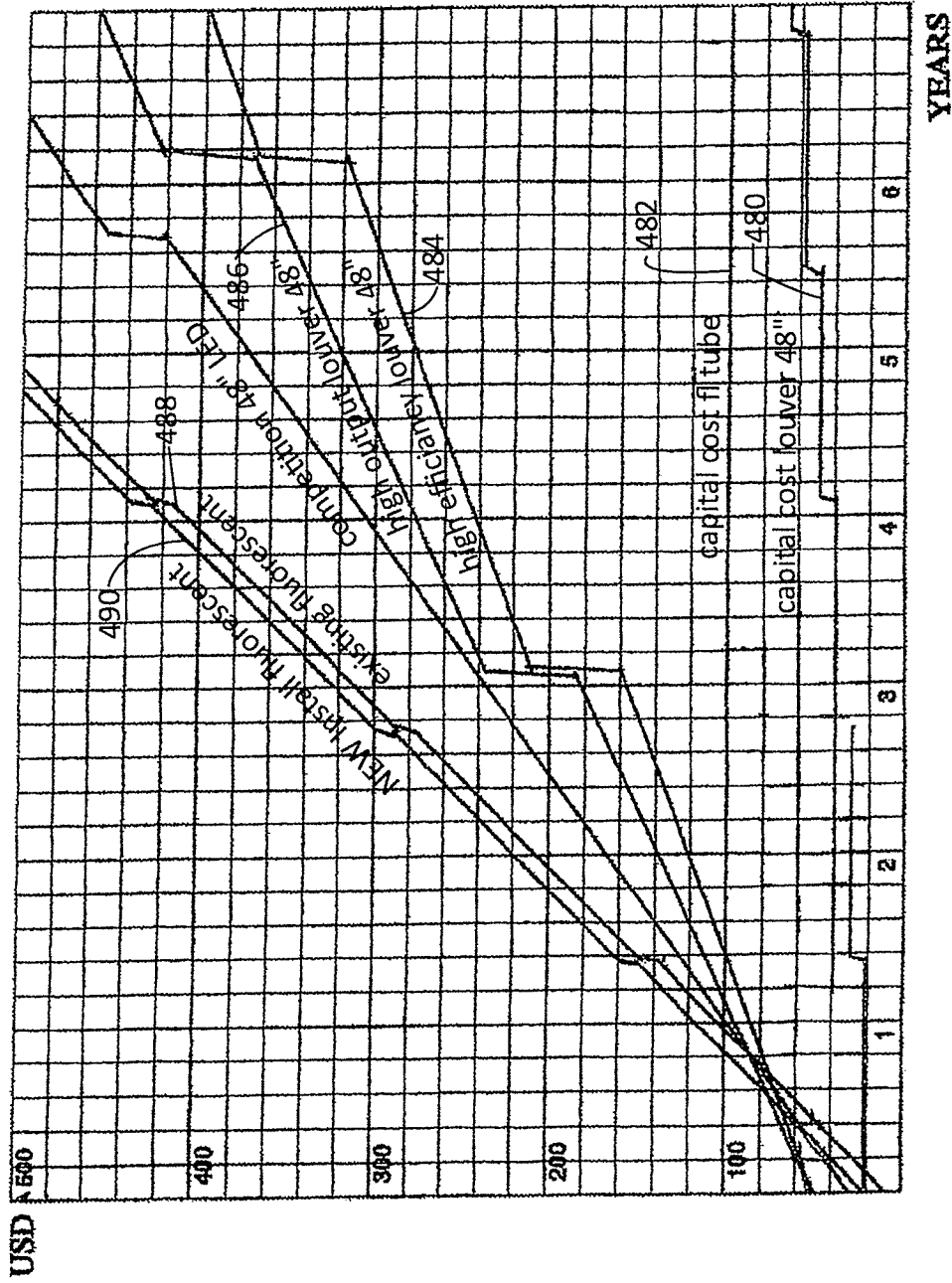
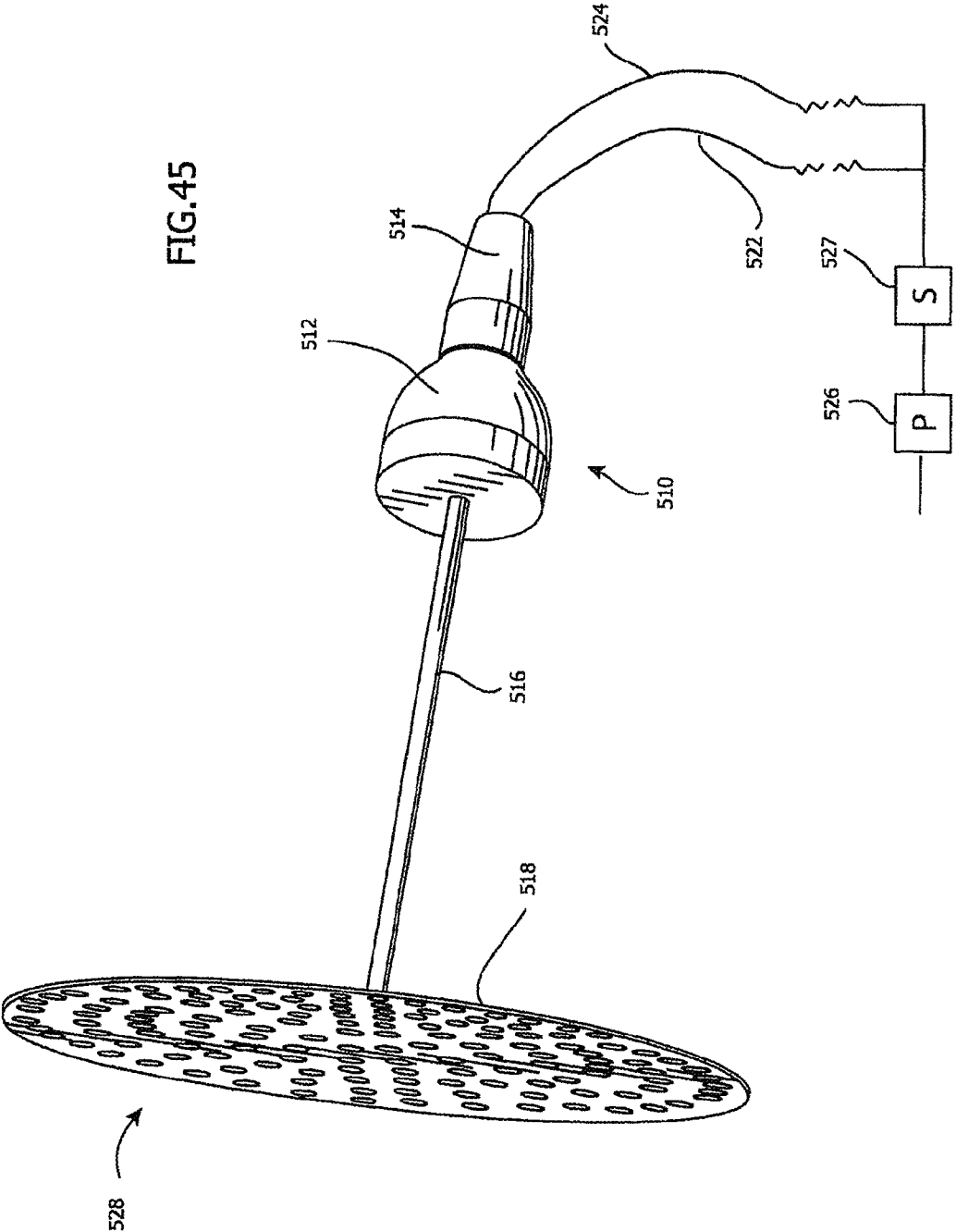

Fig. 44

FIG. 45



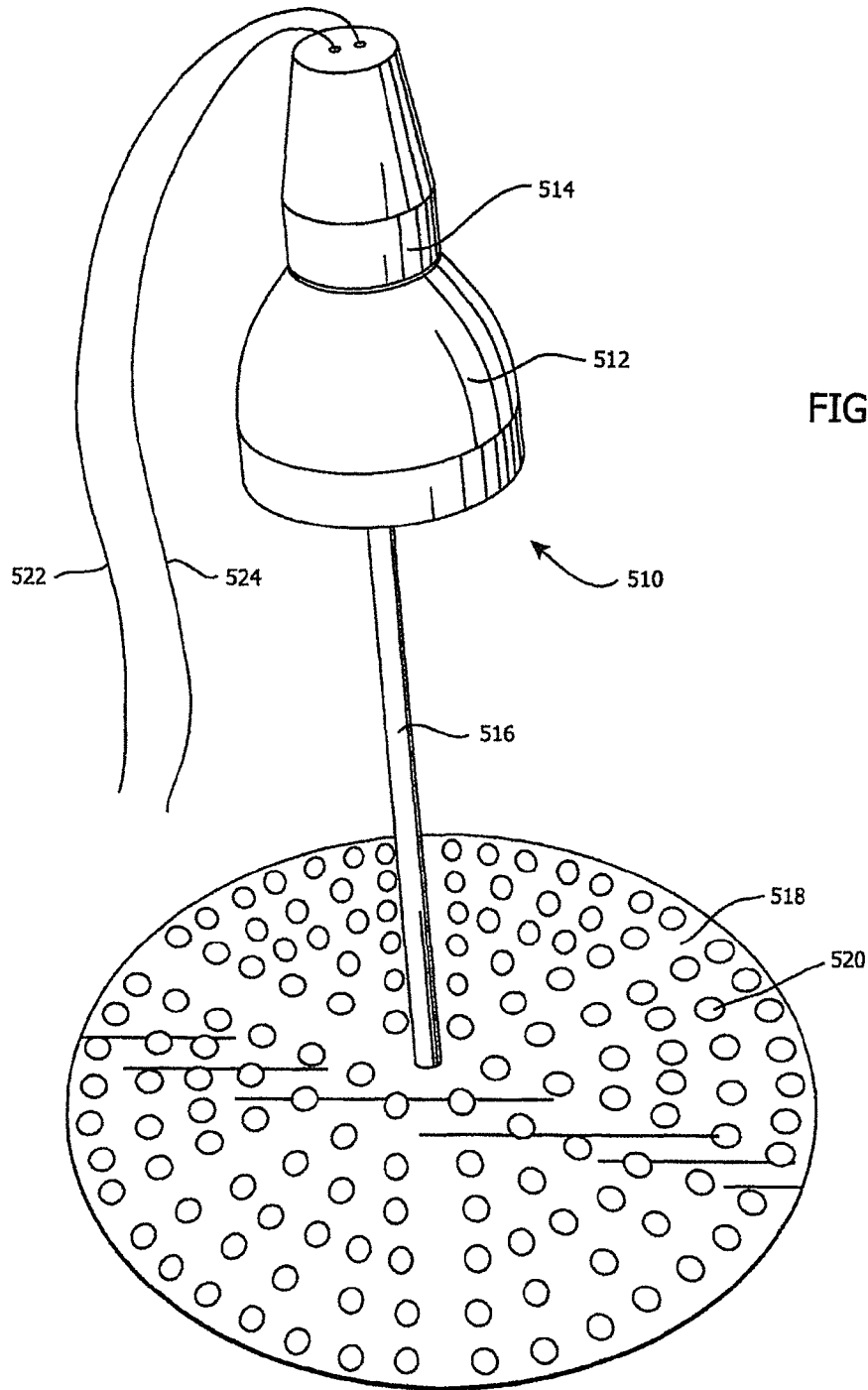

FIG. 46

Fig. 47

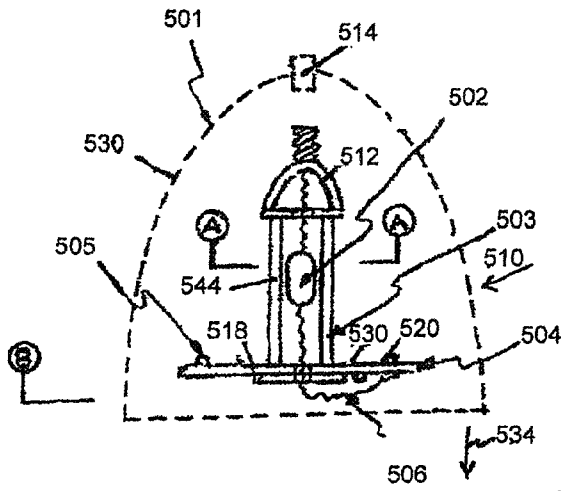

Fig. 48

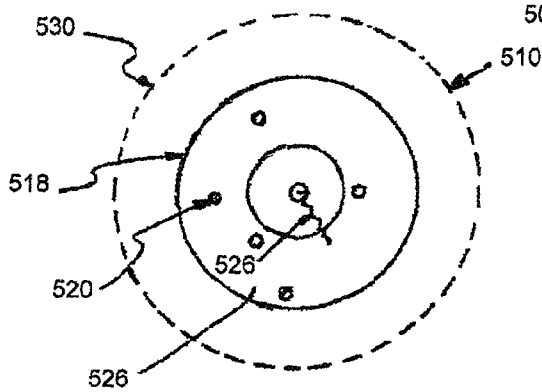
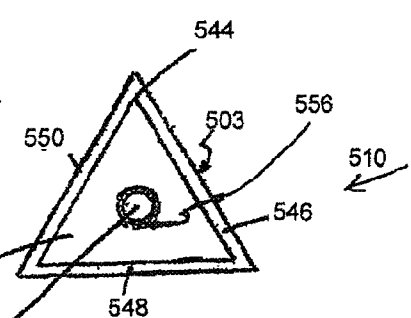

Fig. 49

Fig. 50

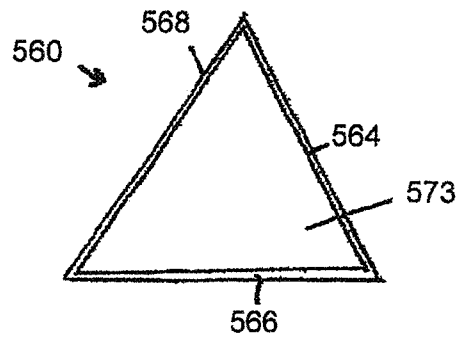

Fig. 51

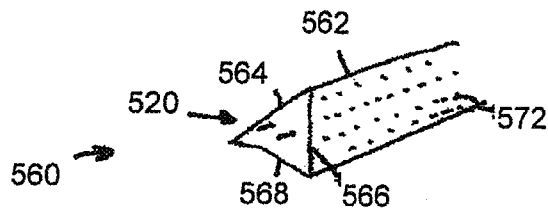

Fig. 52

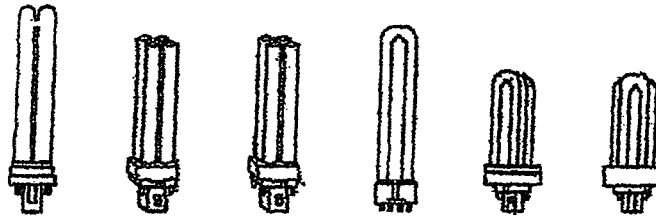

Fig. 53

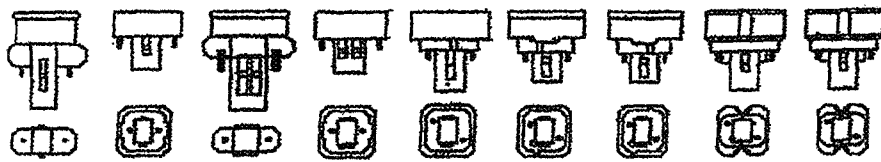

Fig. 54

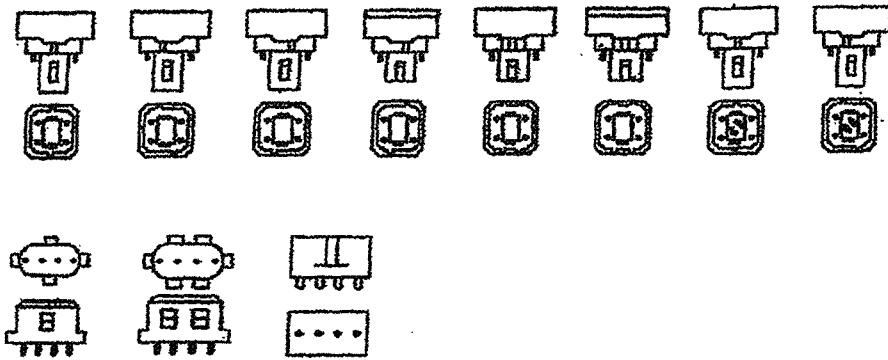

Fig. 55 Prior Art

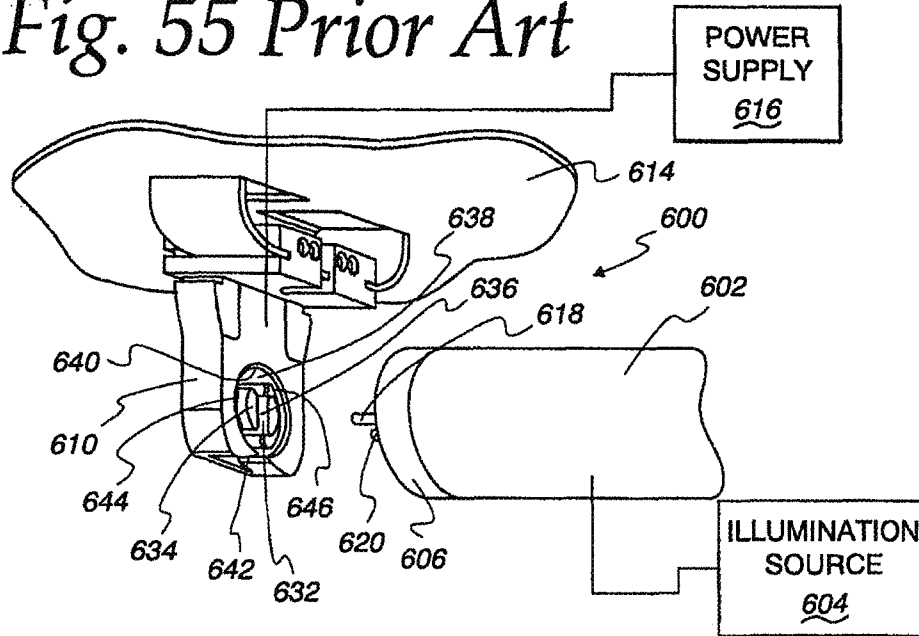

Fig. 56 Prior Art

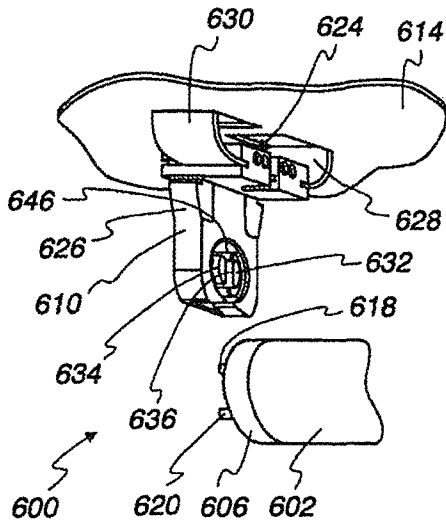

Fig. 57 Prior Art

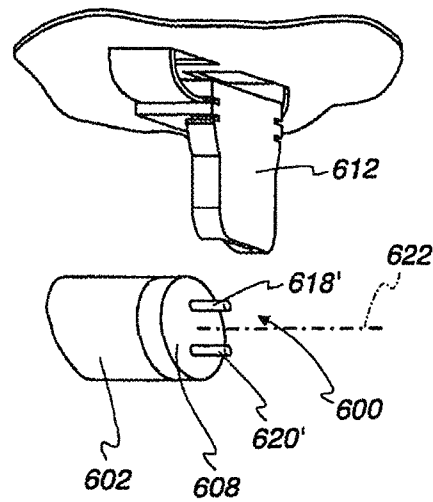

Fig. 58
Prior Art

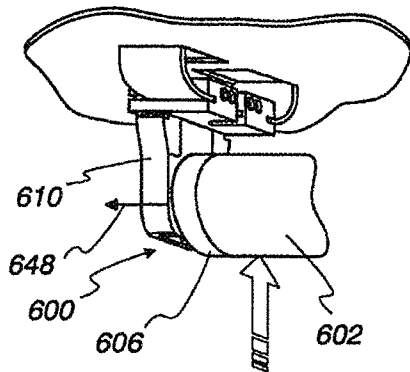

Fig. 59
Prior Art

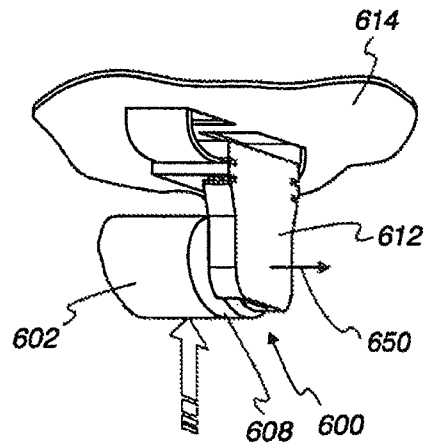

Fig. 60
Prior Art

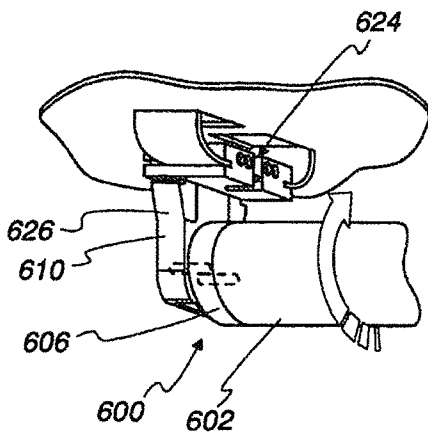

Fig. 61
Prior Art

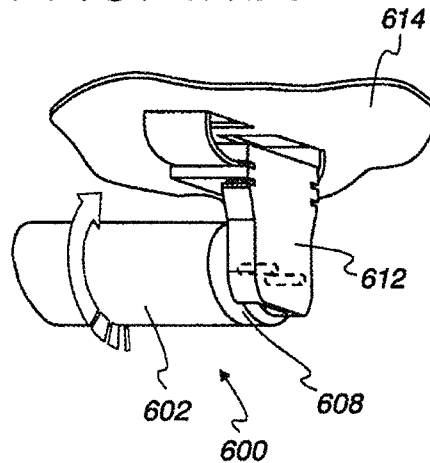

Fig. 62

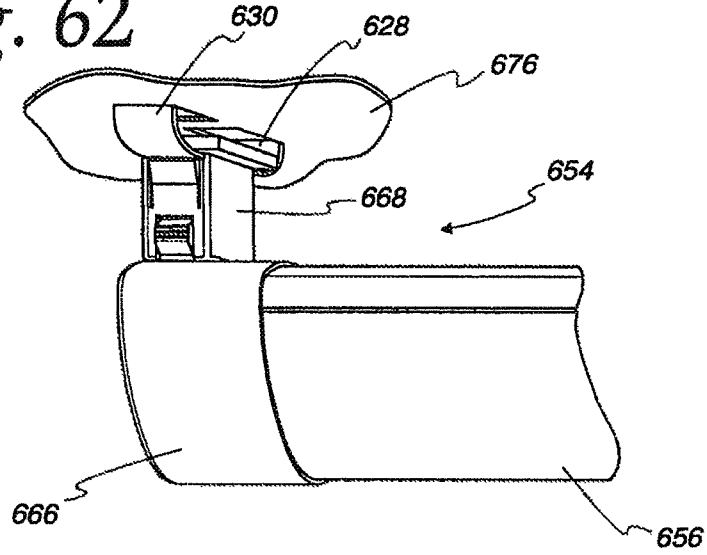

Fig. 63

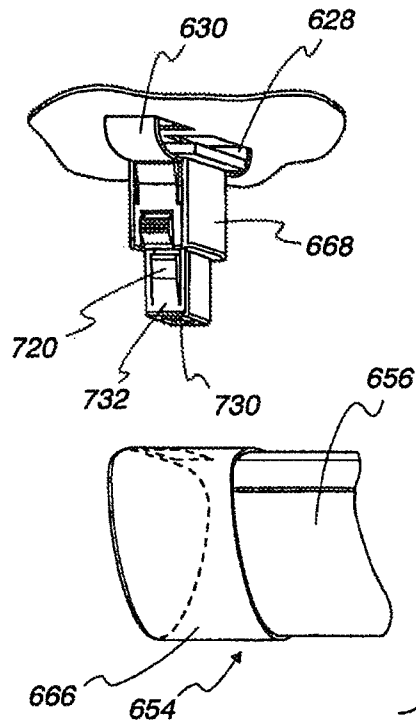

Fig. 64

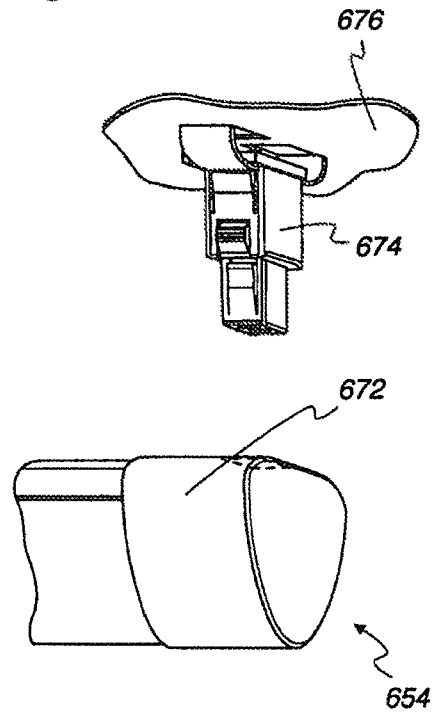

Fig. 65

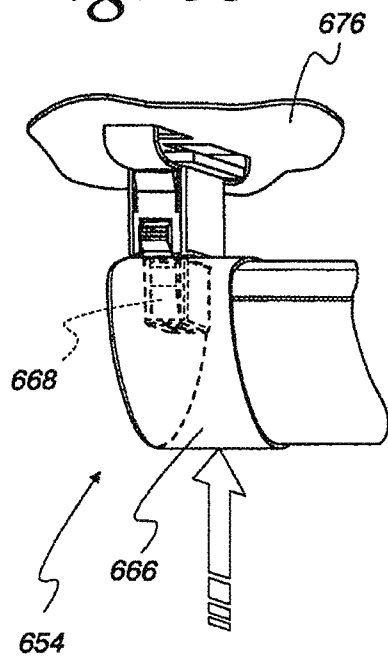
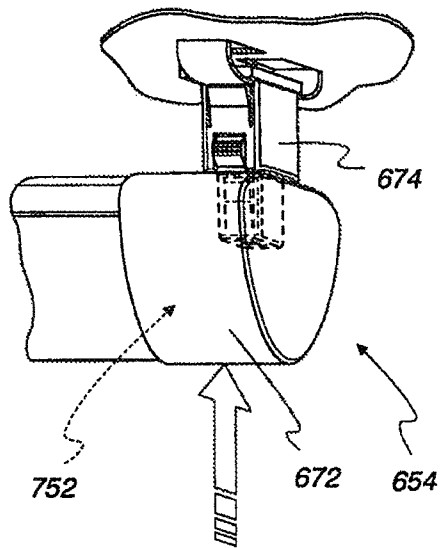

Fig. 66



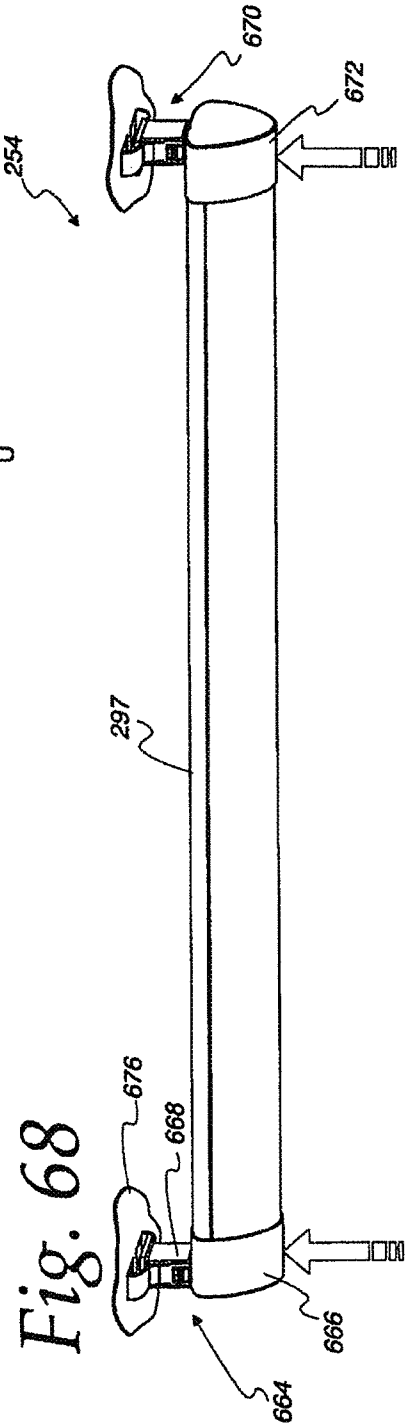
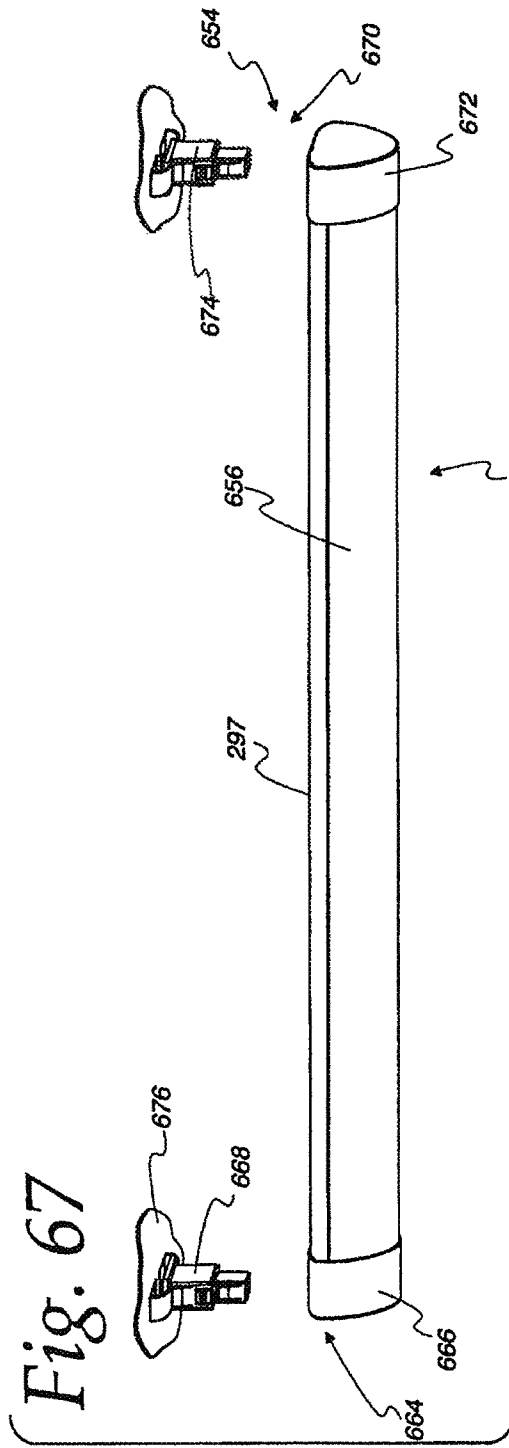
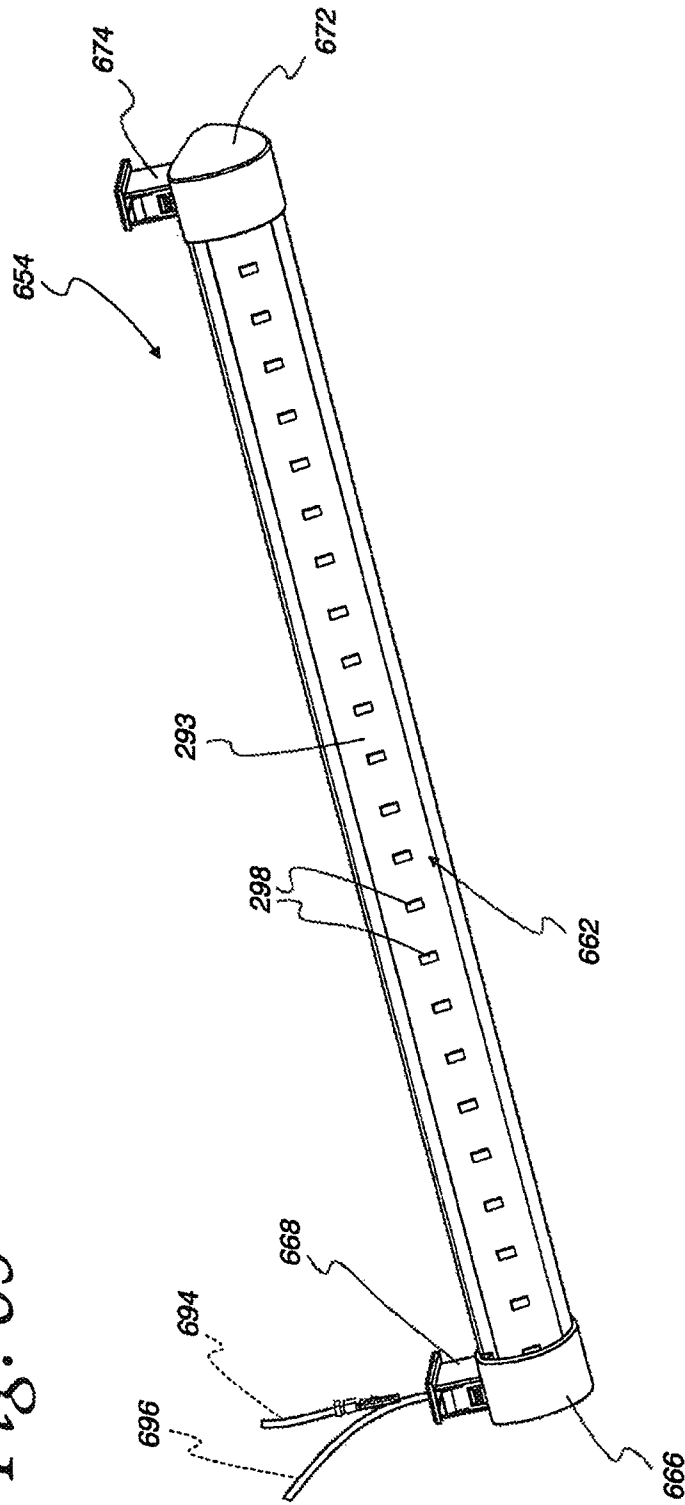

Fig. 69



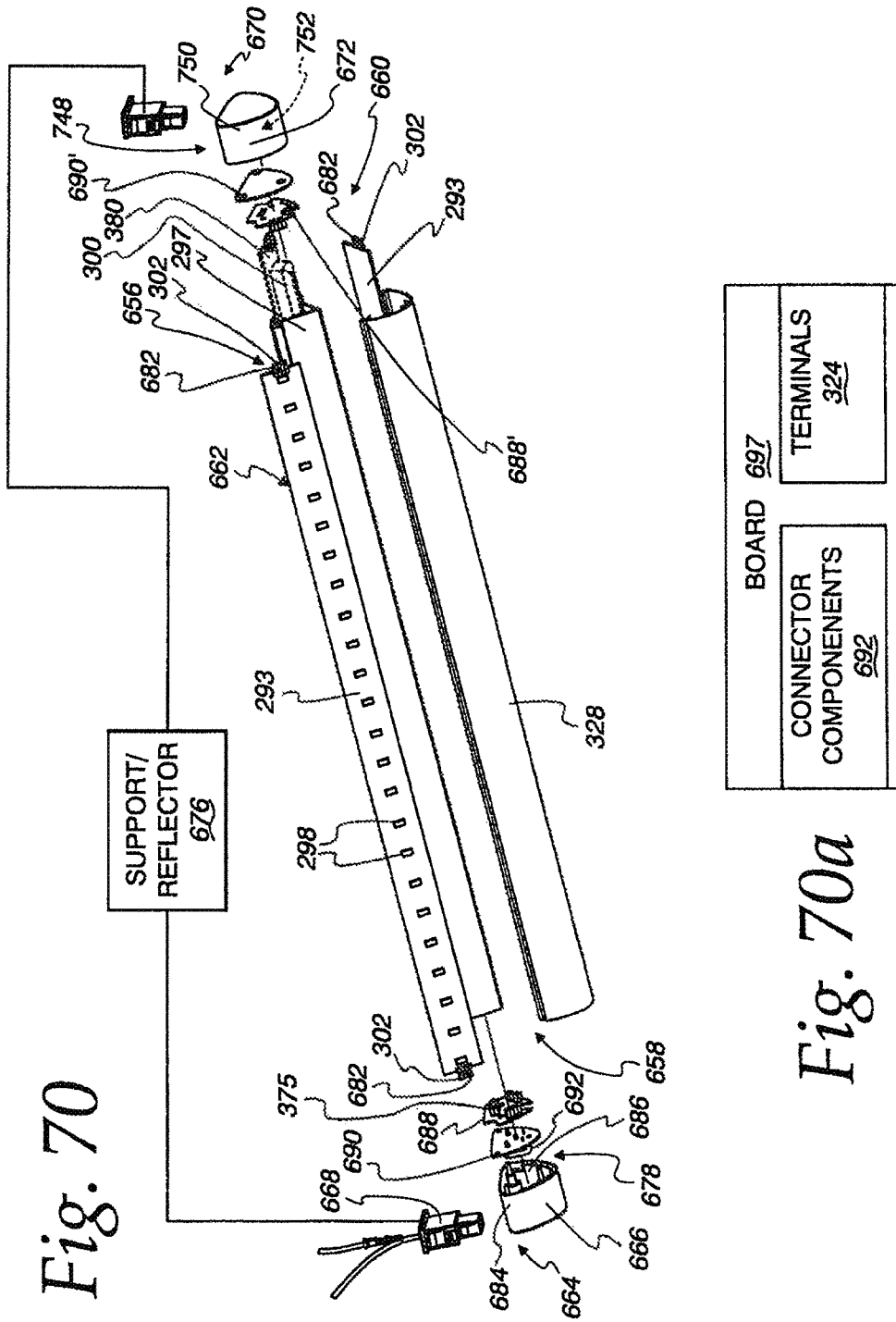

Fig. 70a

Fig. 71

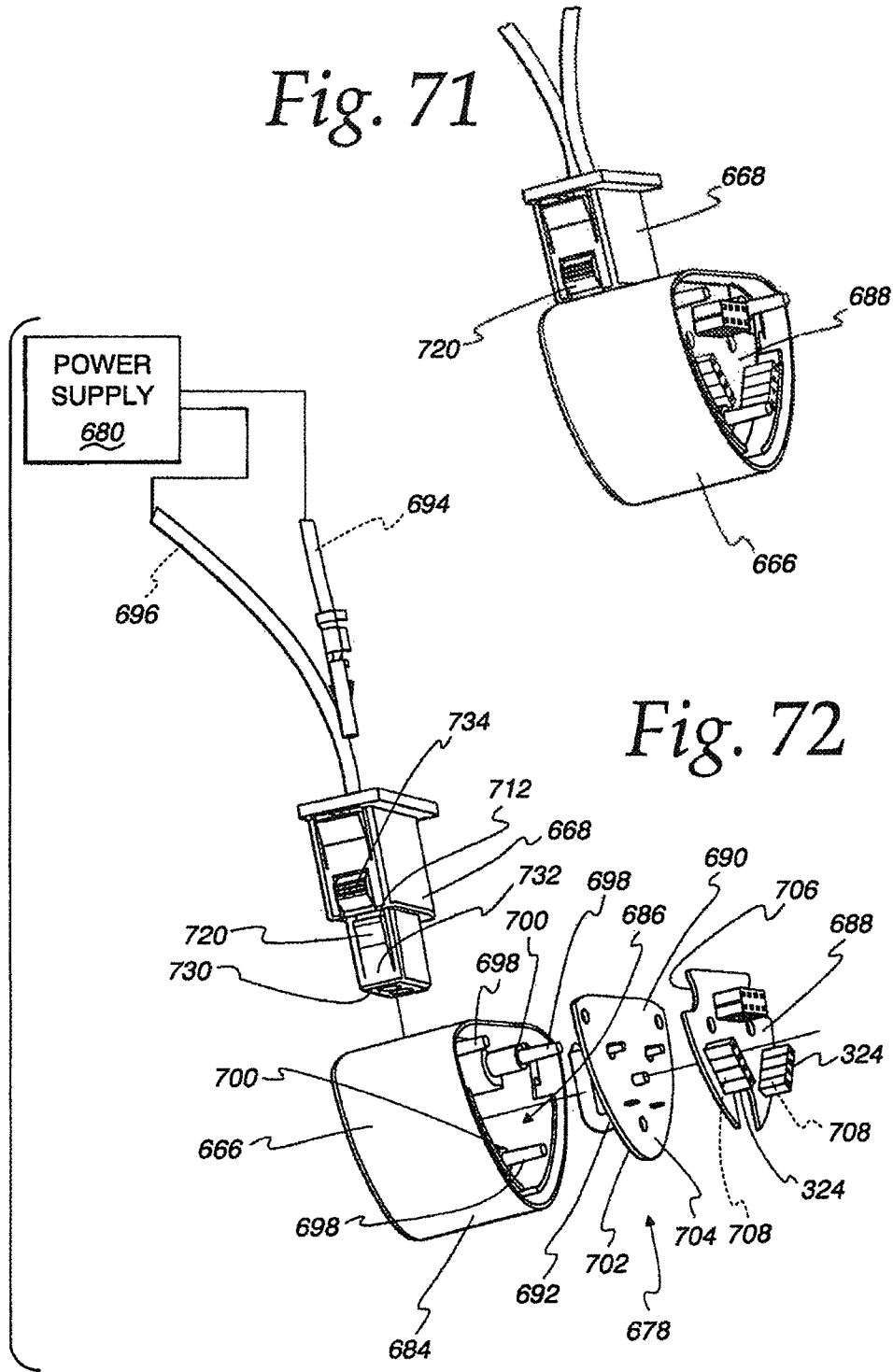

Fig. 72

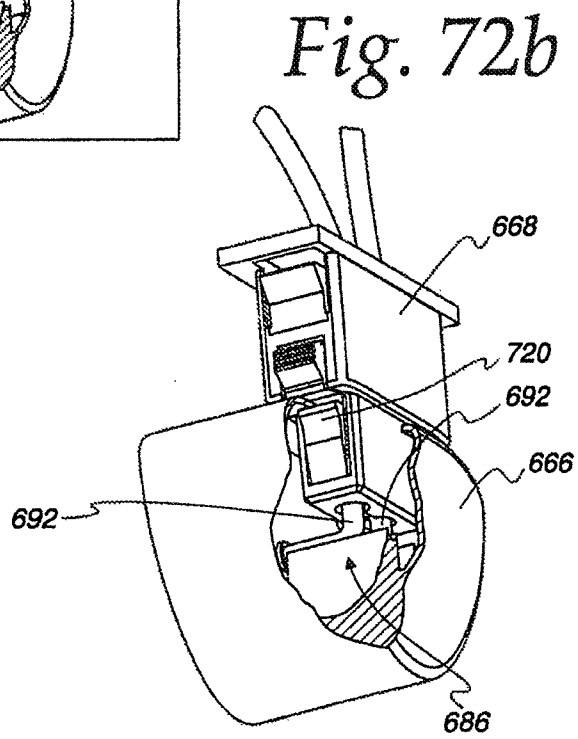
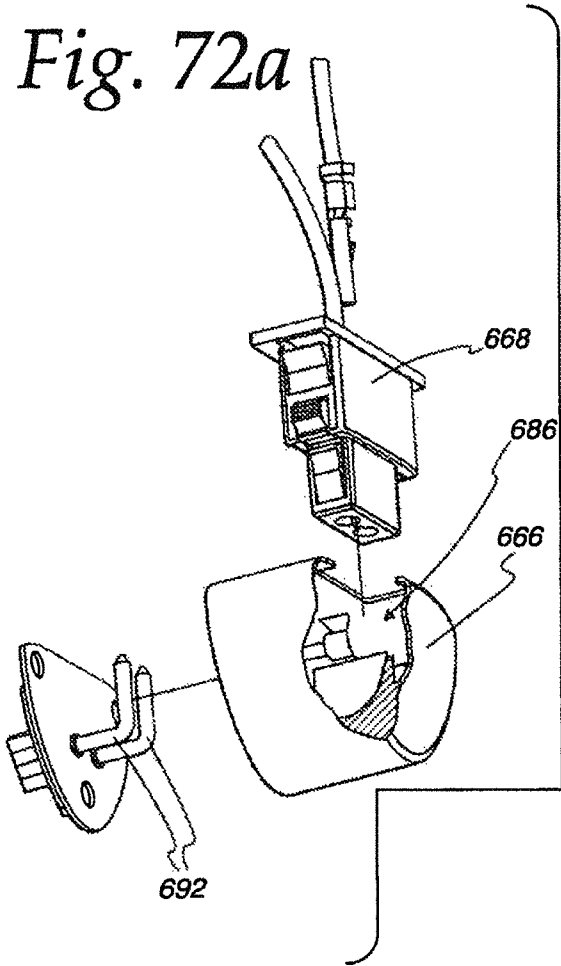

Fig. 73

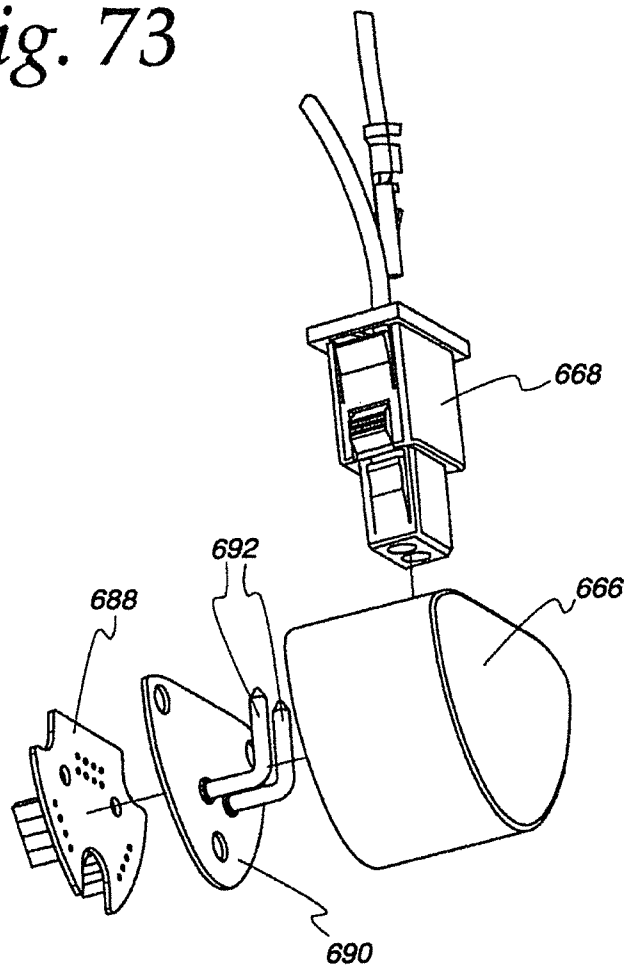

Fig. 74

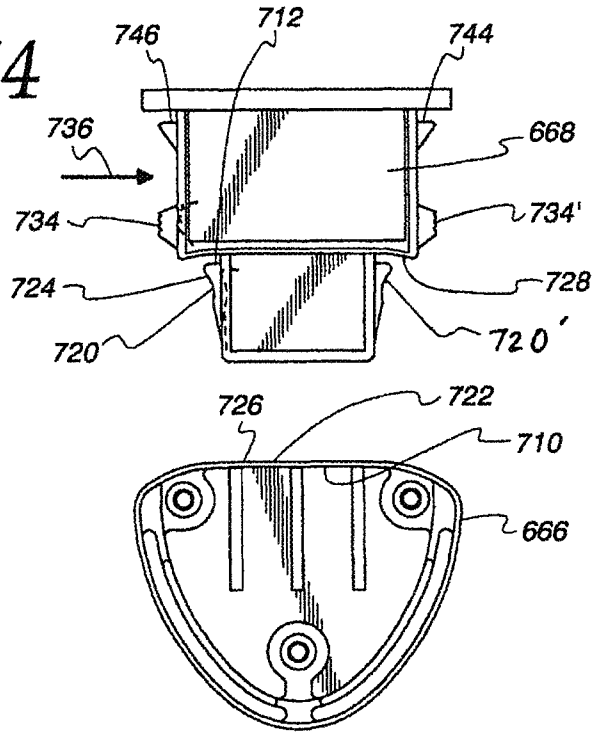

Fig. 75

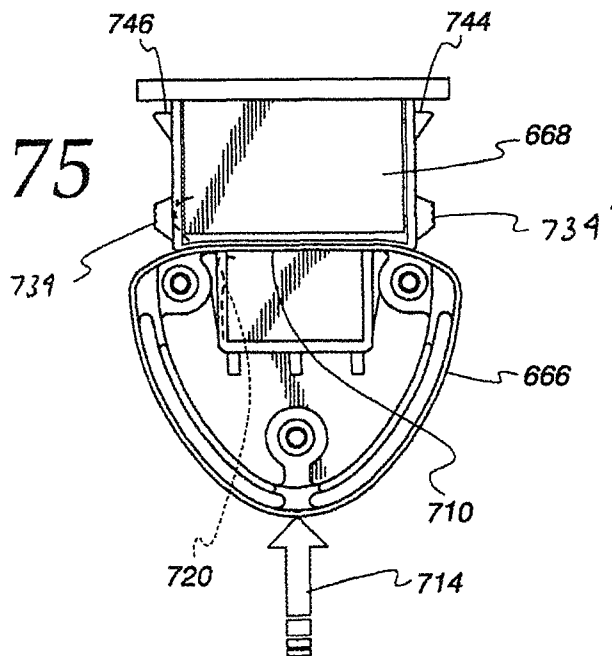

Fig. 76

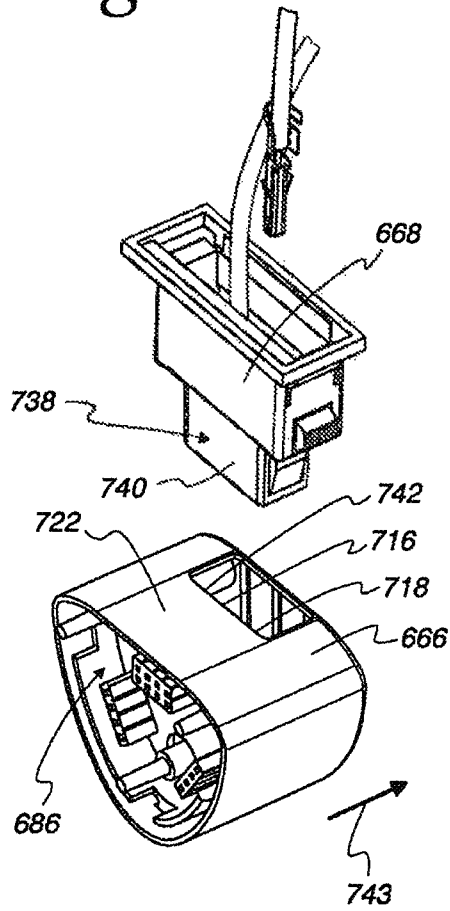
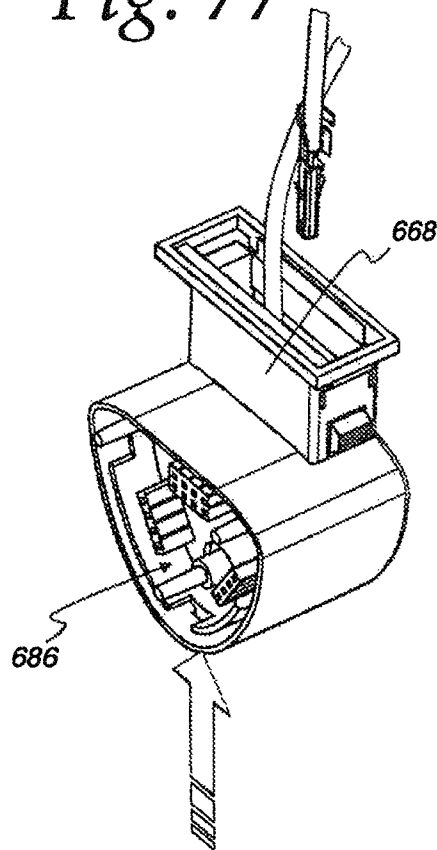

Fig. 77



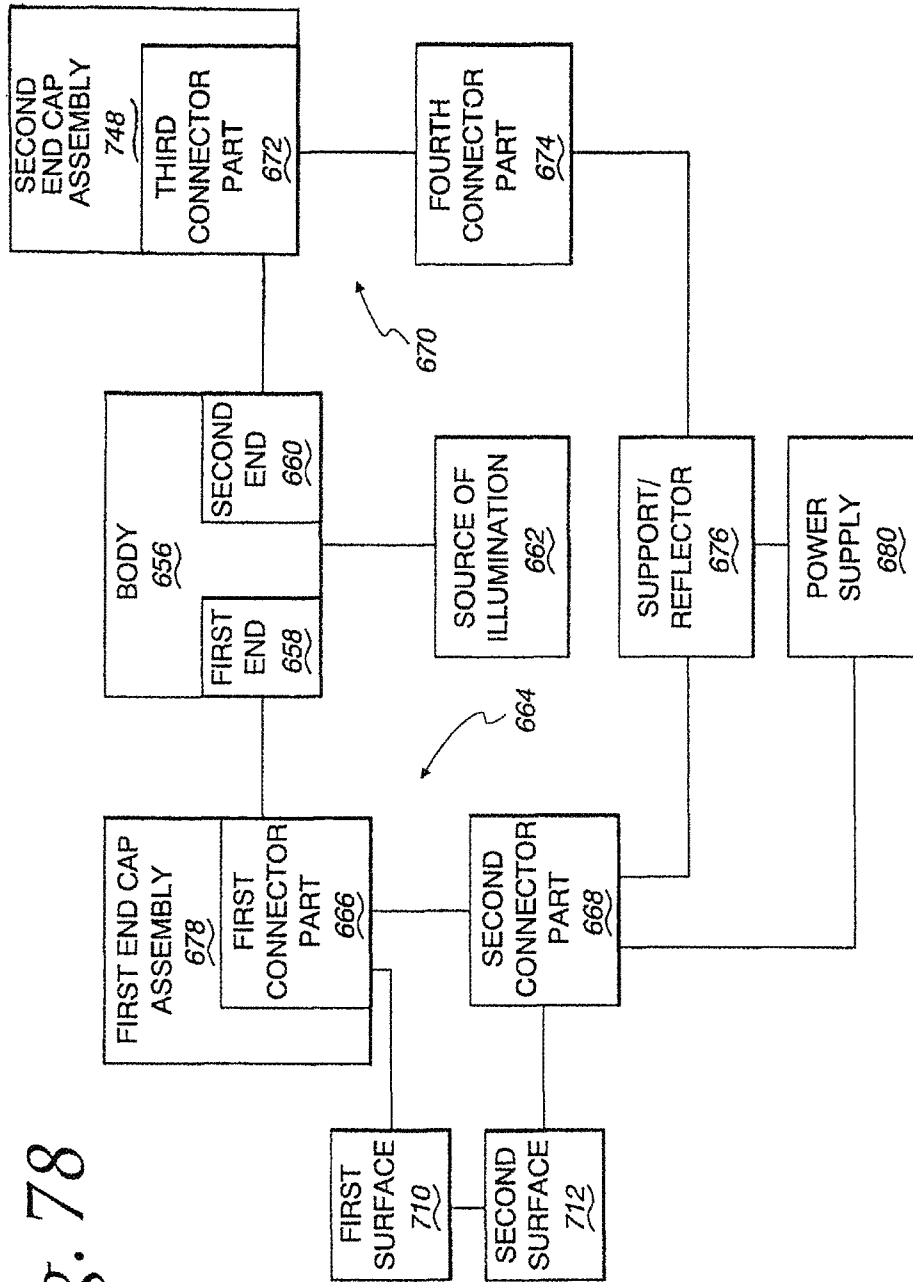

Fig. 78

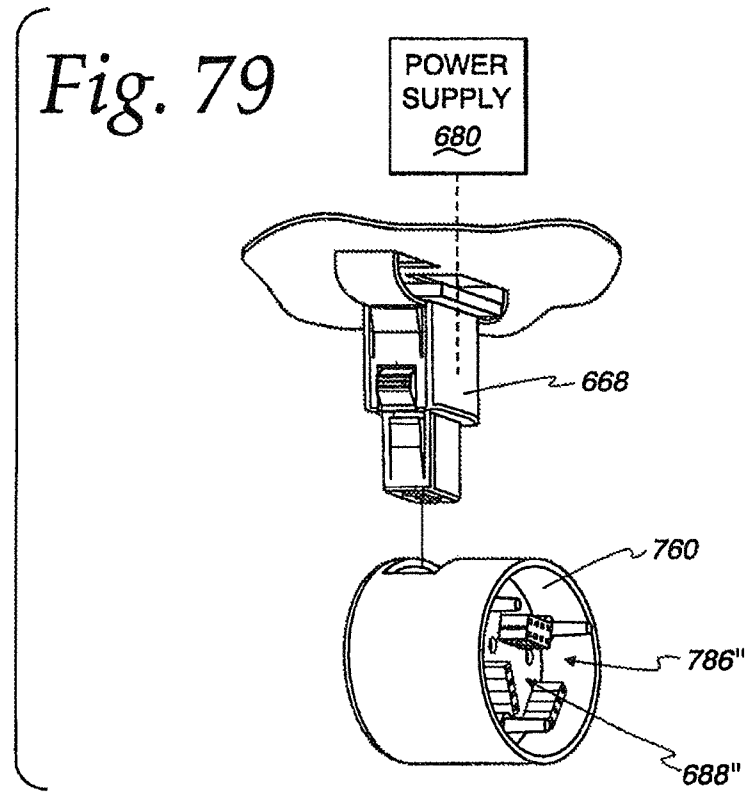
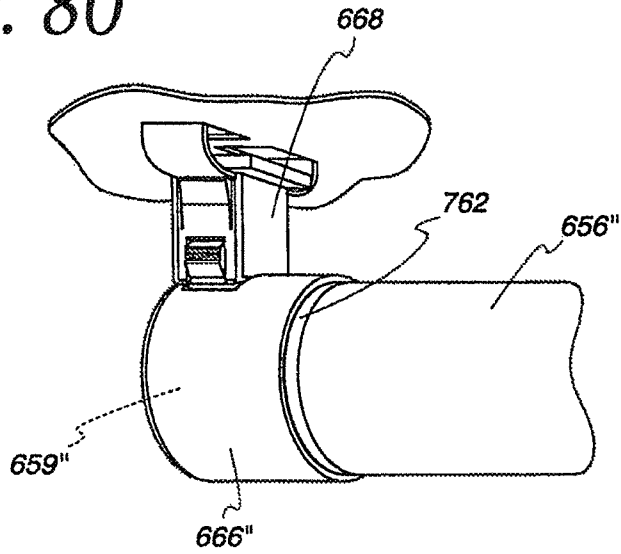

Fig. 80



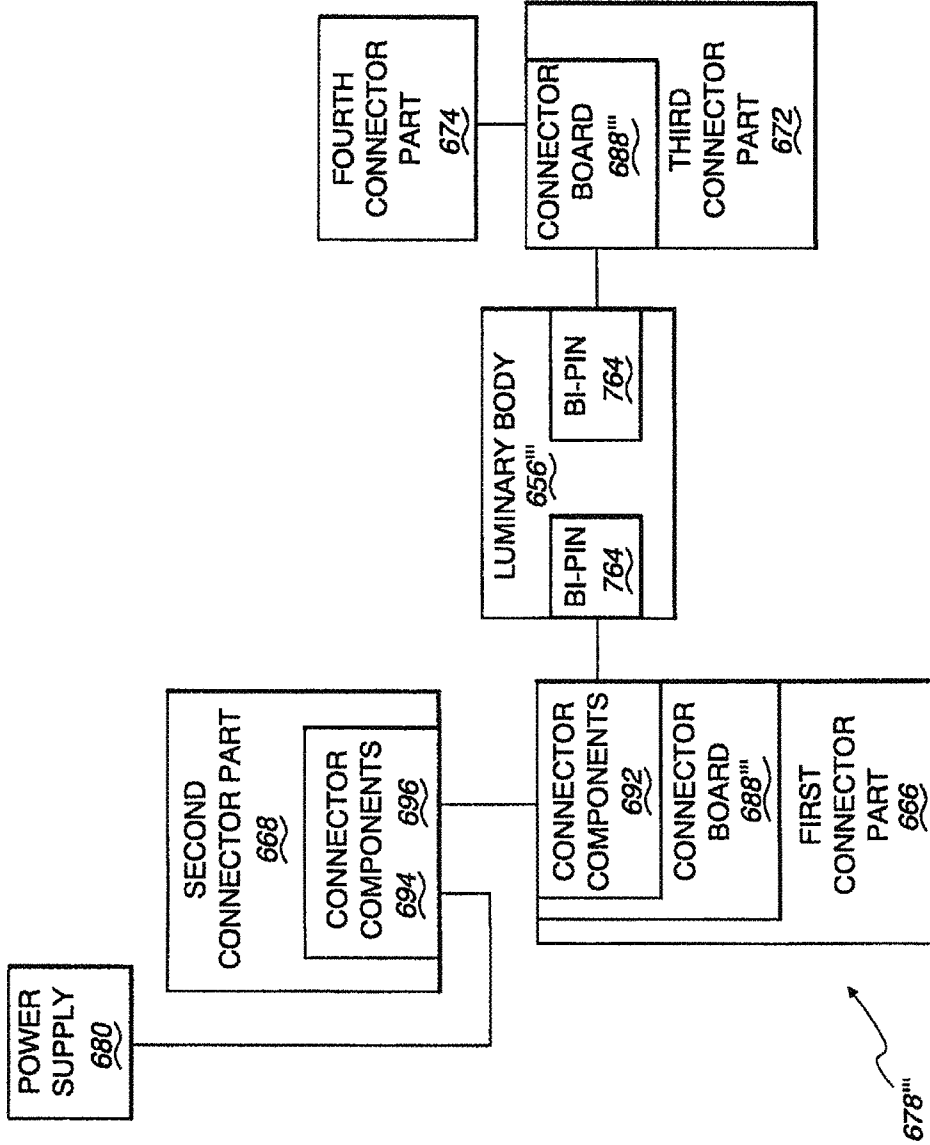
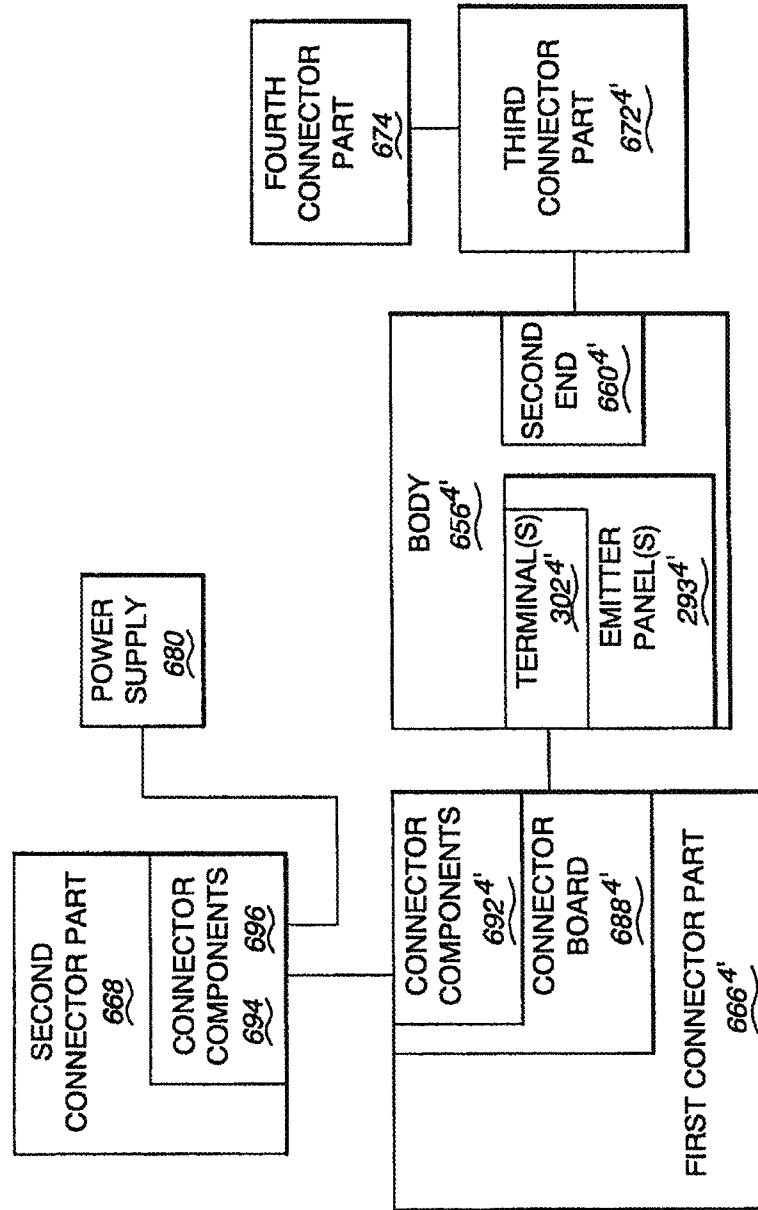

Fig. 81

Fig. 82



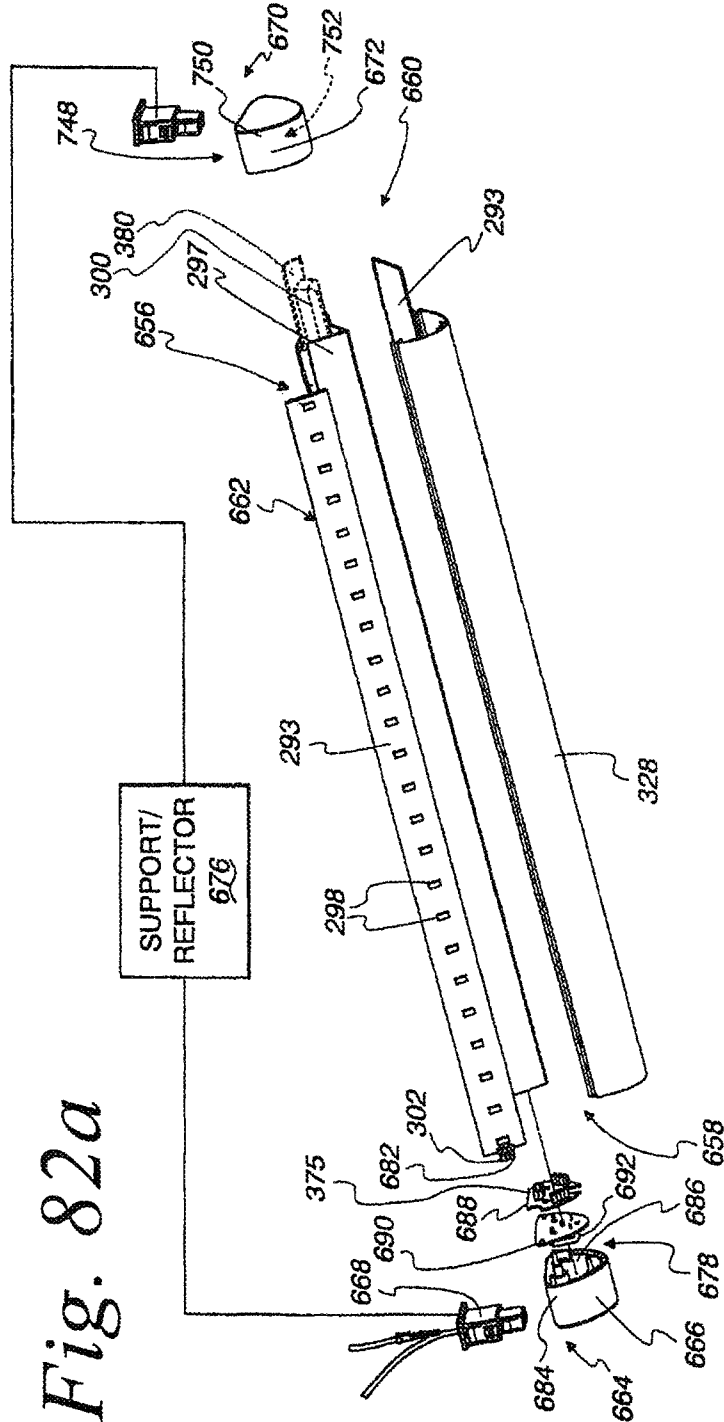

Fig. 82a

Fig. 83

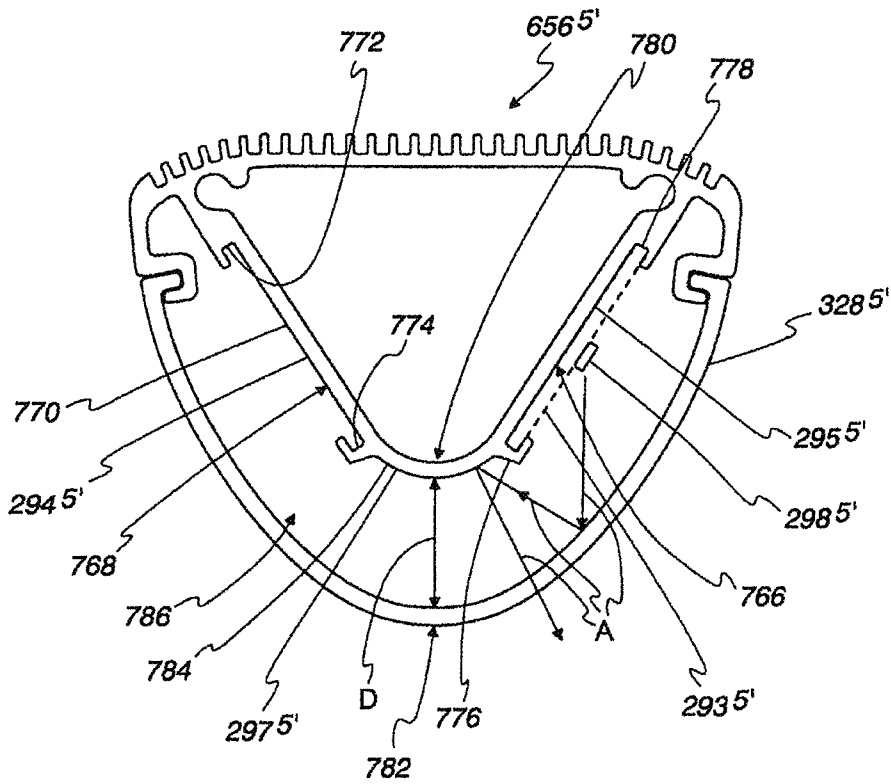

Fig. 84

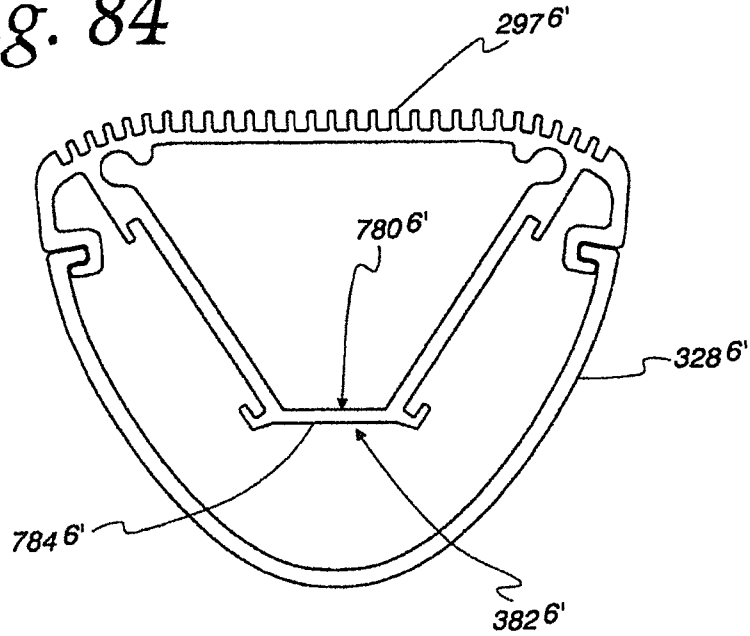

Fig. 85

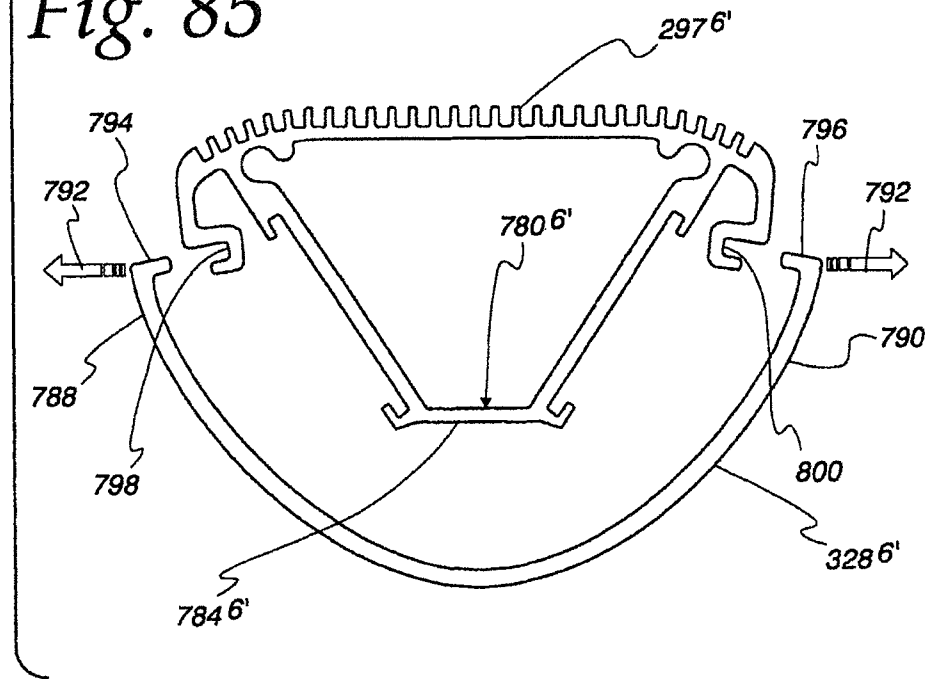
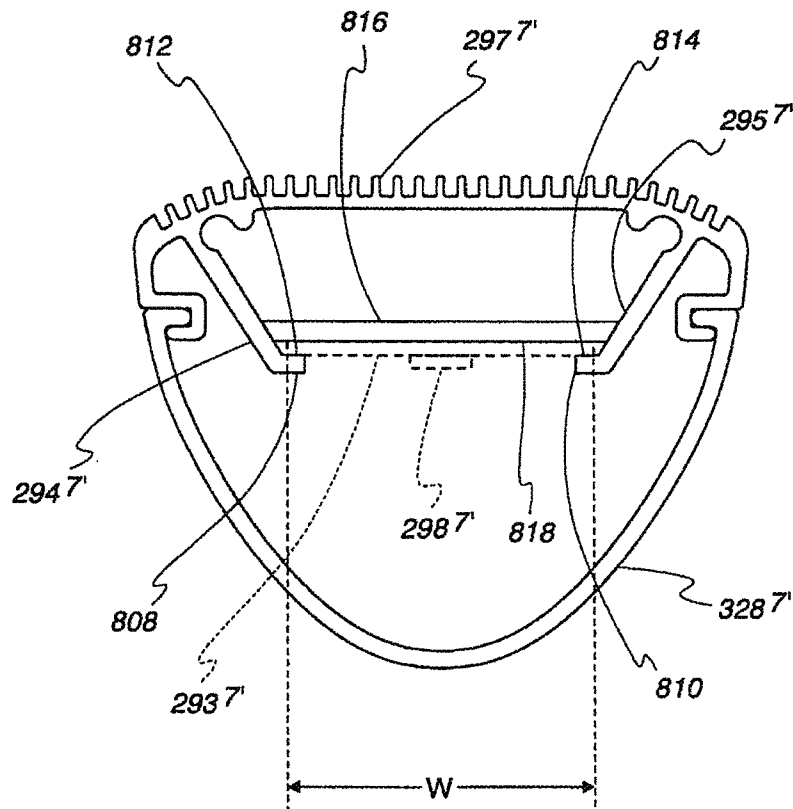
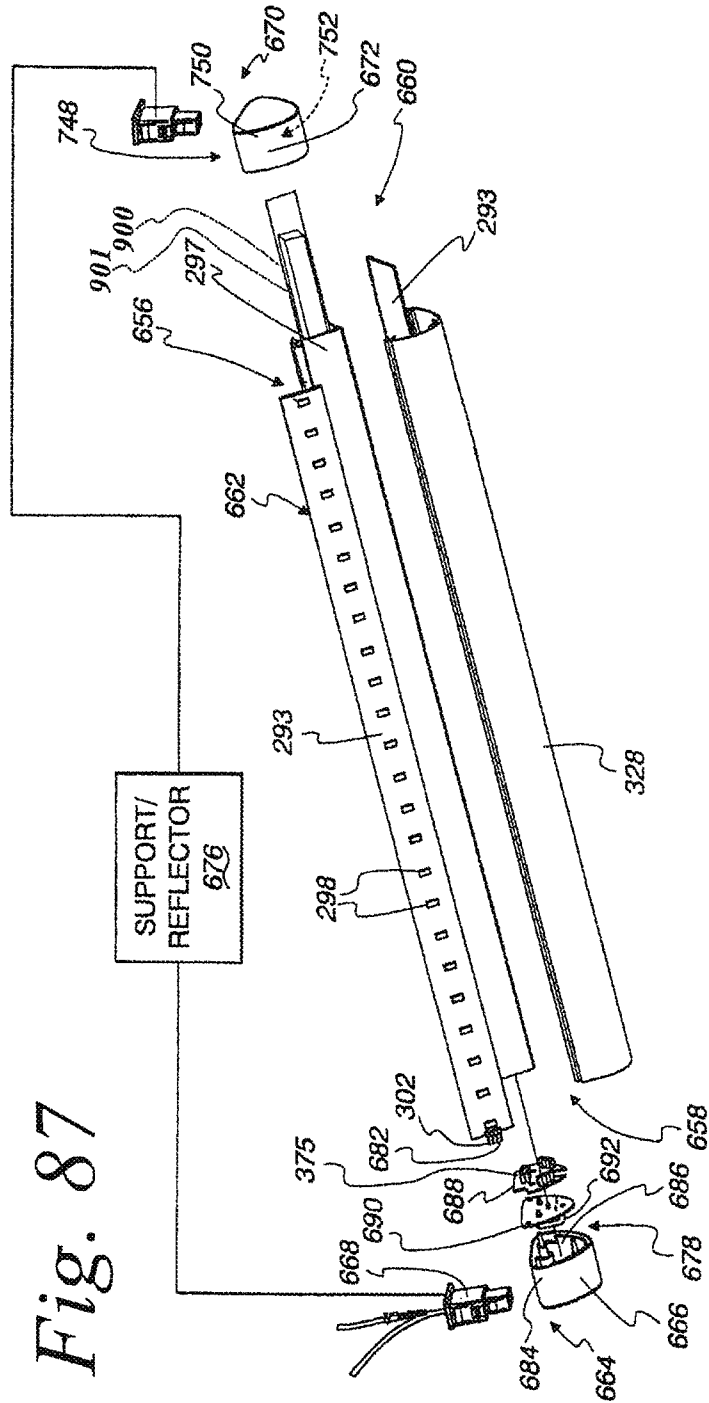

Fig. 86





LIGHTING ASSEMBLY**CROSS-REFERENCE TO RELATED APPLICATION**

This application is a continuation of U.S. application Ser. No. 14/256,066, filed Apr. 18, 2014, now U.S. Pat. No. 9,228,727 which is a continuation-in-part of U.S. application Ser. No. 13/440,423, filed Apr. 5, 2012, now U.S. Pat. No. 8,702,265 which are both hereby incorporated by reference as if fully set forth herein.

FIELD OF THE INVENTION

This invention relates to lighting and, more particularly, to light emitting diode (LED) illumination as well as tubular lighting assemblies.

BACKGROUND ART

Over the years various types of illuminating assemblies and devices have been developed for indoor and/or outdoor illumination, such as torches, oil lamps, gas lamps, lanterns, incandescent bulbs, neon signs, fluorescent bulbs, halogen lights, and light emitting diodes. These conventional prior art illuminating assemblies and devices have met with varying degrees of success.

Incandescent light bulbs create light by conducting electricity through a thin filament, such as a tungsten filament, to heat the filament to a very high temperature so that it glows and produces visible light. Incandescent light bulbs emit a yellow or white color. Incandescent light bulbs, however, are very inefficient, as over 98% of its energy input is emitted and generated as heat. A standard 100 watt light bulb emits about 1700 lumens, or about 17 lumens per watt. Incandescent lamps are relatively inexpensive and have a typical lifespan of about 1,000 hours.

Fluorescent lamps (light bulbs) conduct electricity through mercury vapor, which produces ultraviolet (UV) light. The ultraviolet light is then absorbed by a phosphor coating inside the lamp, causing it to glow, or fluoresce. While the heat generated by fluorescent lamps is much less than its incandescent counterpart, energy is still lost in generating the UV light and converting UV light into visible light. If the lamp breaks, exposure to mercury can occur. Linear fluorescent lamps are often five to six times the cost of incandescent bulbs but have life spans around 10,000 and 20,000 hours. Lifetime varies from 1,200 hours to 20,000 hours for compact fluorescent lamps. Some fluorescent lights flicker and the quality of the fluorescent light tends to be a harsh white due to the lack of a broad band of frequencies. Most fluorescent lights are not compatible with dimmers.

Light emitting diode (LED) lighting is particularly useful. Light emitting diodes (LEDs) offer many advantages over incandescent light sources, including: lower energy consumption, longer lifetime, improved robustness, smaller size, faster switching, and excellent durability and reliability. LEDs emit more light per watt than incandescent light bulbs. LEDs can be tiny and easily placed on printed circuit boards. LEDs activate and turn on very quickly and can be readily dimmed. LEDs emit a cool light with very little infrared light. LEDs come in multiple colors which are produced without the need for filters. LEDs of different colors can be mixed to produce white light. Other advantages of LEDs include: high efficiency; low energy consumption; higher outputs at higher drive currents; shock

resistant with no filament, glass or tube to break, contain no toxic substances, hazardous mercury or halogen gases.

The operational life of some white LED lamps is 100,000 hours and 11 years of continuous operation. The long operational life of an LED lamp is much longer than the average life of an incandescent bulb, which is approximately 5000 hours. If the lighting device needs to be embedded into a very inaccessible place, using LEDs would minimize the need for regular bulb replacement. With incandescent bulbs, the cost of replacement bulbs and the labor expense and time needed to replace them can be significant especially where there are a large number of incandescent bulbs. For office buildings and high rise buildings, maintenance costs to replace bulbs can be expensive and can be substantially decreased with LED lighting.

An important advantage of LED lighting is reduced power consumption. An LED circuit will approach 80% efficiency, which means 80% of the electrical energy is converted to light energy; the remaining 20% is lost as heat energy. Incandescent bulbs, however, operate at about 20% efficiency with 80% of the electrical energy is lost as heat. Repair and replacement savings can be significant, as most incandescent light bulbs burn out within a year and require replacements whereas LED light bulbs can be used easily for a decade without burning out.

LED light (lighting) bars are considered to be much better than incandescent lights. Incandescent light bulbs do not last for a long time and the filament burns out. An LED light bar consumes less energy and has a longer life. LED light output is much brighter than that of an incandescent light bulb.

An assortment of colors and flash patterns are available with LED light bars for emergency vehicles such as police cars, fire trucks and ambulances. Emergency vehicles such as ambulances and police cars prefer mounting a LED light bar on the top for easy recognition and visibility. LED light bars can be used on the interior as well as on the exterior of the emergency vehicles as it emits sufficient light even in the darkest of areas. Furthermore, since the heat produced by LED light bars is small, it won't adversely affect the interior of the vehicle.

LEDs are used in applications as diverse as aviation lighting, traffic signals and automotive lighting such as brake lights, turn signals and indicators. LEDs have a compact size, fast switching speed and good reliability. LEDs are useful for displaying text and video and for communications. Infrared LEDs are also used in the remote control units of many commercial products including televisions, DVD players and other domestic appliances.

Solid state devices such as LEDs have excellent wear and tear if operated at low currents and at low temperatures. LED light output actually rises at colder temperatures (leveling off depending on type at around -30 C.^o). Consequently, LED technology may be a good replacement for supermarket freezer lights and will often last longer than other types of lighting.

Large-area LED signs and displays are used as stadium displays and as decorative displays. LED message displays are used at airports and railway stations, and as destination displays for trains, buses, trams, and ferries.

With the development of efficient high power LEDs, it has become more advantageous to use LED lighting and illumination. High power white light LED lighting is useful for illumination and for replacing incandescent and/or fluorescent lighting. LED street lights are used on posts, poles and in parking garages. LED's are now used in stores, homes, stage and theaters, and public places. Furthermore, color LED's are useful in medical and educational applications

such as for mood enhancement. In many countries incandescent lighting for homes and offices is no longer available and building regulations require new premises to use LED lighting.

Conventional prior art LED lighting which is powerful enough for room lighting, however, is relatively expensive and requires more precise current and heat management than fluorescent lamp sources of comparable output. Furthermore, conventional LED lighting can have a higher capital cost than other types of lighting and LED light tends to be directional with small areas of illumination. Moreover, conventional LED luminaries suffer from drawbacks due to a lack of lumen output and less than desirable light dispersion. Individually and combined, these aspects of conventional LED lighting can detract from efficient utilization of LED luminaries.

One problem that has plagued the lighting industry is associated with how conventional, elongate, tubular lighting components are operatively mounted through end connectors. As described in greater detail below, conventional tubular lighting, having a source of illumination that is an LED, a gas-discharge lamp that uses fluorescence to produce visible light, or another known source on, or within, a tubular body, typically utilizes a bi-pin/2-pin means on the tubular body that mechanically supports the body in an operative state and effects electrical connection of the illumination source to a power supply.

Typically, the body has a cylindrical shape with a central axis. The pins making up the bi-pin means project in cantilever fashion from the body ends. The body must be situated in a first angular orientation to direct the pins into spaced connectors on a support/reflector and is thereafter turned to effect mechanical securement and electrical connection.

Installation requires a precise initial angular orientation of the body and subsequent controlled repositioning thereof to simultaneously seat the pins at the opposite ends of the body. Often one or more of the pins are misaligned during this process so that electrical connection is not established. The same misalignment may cause a compromised mechanical connection whereupon the body may escape from the connectors and drop so that it is damaged or destroyed.

Further, the connectors on the support/reflector are generally mounted in such a fashion that they are prone to flexing. Even a slight flexing of the connectors on the support might be adequate to release the pins at one body end so that the entire body becomes separated. Furthermore, the conventional bi-pin means for mechanically holding the body in place, while also allowing power to be distributed to the illumination source, was created for very lightweight fluorescent lighting and not designed for LED tubular lighting that has additional weight due to the required heat sink and PCB boards. The weight of the body by itself may produce horizontal force components that wedge the connectors on the support/reflector away from each other so that the body becomes precariously situated or fully releases.

A still further problem with this type of lighting configuration, particularly with an LED illumination source, is that the end connectors joined to the body are by their nature difficult to consistently assemble. Typically, the manufacturing process will involve steps of soldering conductive components on, and cooperating between, the end connectors and illumination source. Wires are commonly used in these designs, with the ends thereof soldered during the assembly process. If the conductive components are not properly connected, the system may be inoperable. Soldered connections are also prone to failing when subjected to

forces in use. Generally, it is difficult to maintain a high level of quality control, regardless of the care taken in assembling these types of components. Aside from the quality issue, the assembly steps that involve the electrical connection of the conductors are inherently time consuming and may require relatively skilled labor, and/or expensive automated systems. Disassembly of such lamps presents similar difficulties and expense. As a result of these difficulties associated with assembly and disassembly, refurbishing such lamps to replace defective or worn out components is difficult to justify economically. In most cases, the entire lamp assembly will simply be discarded and replaced with a new lamp assembly, and as a result, lamp components that have significant useful life remaining are wasted.

Still another problem in the lighting industry are the difficulties and costs associated with proper design and control of emergency lighting circuits. Emergency lighting systems are required by a myriad of municipal, state, federal or other codes and standards. These systems are intended to automatically supply illumination to designated areas and equipment in the event of failure of the normal power supply, to protect people and allow safe egress from a building, and to provide lighting to areas that would aid rescuers or repair crews. These systems are typically required by regulation to be available within a short time (e.g. 10 seconds) after failure of normal power, and emergency circuits must be physically separated from all other circuits all the way to the terminations and the source. Other standby systems, although not legally required, may be desirable to provide lighting to prevent discomfort or serious damages to a product or process.

The proper design and control of emergency lighting circuits in compliance with the many standards and codes that may apply to a given site installation has long presented difficult challenges for manufacturers, systems integrators and electricians and engineers. As a result, a number of approaches to the designing emergency or standby lighting circuits have been attempted. One known approach involves providing a number of emergency-only luminaires dedicated to providing minimum illumination levels and powered by a dedicated emergency breaker panel fed from a generator or uninterruptable power supply (UPS). An uninterruptible power supply is an electrical apparatus that provides emergency power to a load when the input power source, typically mains power, fails. A UPS differs from an auxiliary or emergency power system or standby generator in that it will provide near-instantaneous protection from input power interruptions, by supplying energy stored in batteries or a flywheel. Regardless of the source of back-up power, the emergency fixtures remain dark when normal power is present, and are energized when the control circuit detects failure of the normal power supply. This approach entails the potentially high cost of the emergency system equipment and may be visually unappealing as result of excess luminaries which are not illuminated during normal conditions.

Another approach involves self-contained battery pack emergency lights, which contain a battery, a charger, and a load control relay. These units are connected to normal power, which provides a constant charging current for the battery. During a power failure, the load control relay energizes the emergency lights. This approach avoids the need to deploy physically separated emergency circuits, but is typically implemented in aesthetically unpleasing forms resembling a car headlight battery pack unit.

Still another approach uses the same light fixture for both normal an emergency use. The lights are fed using the normal breaker panel and wall mounted switch during

normal operation. When power fails, an emergency transfer circuit transfers the breaker panel feed to an emergency power source, and bypasses the wall switch to force the load on the lights regardless of the wall switch position. Although such systems offer aesthetic advantages, they are expensive and complex to design and install. Other known approaches suffer similar drawbacks.

It is, therefore, desirable to provide an improved LED illuminating assembly, which overcomes some, if not all, of the preceding problems and disadvantages.

SUMMARY OF THE INVENTION

The disclosure of U.S. patent application Ser. No. 13/440,423 is hereby incorporated by reference as if fully set forth herein. An improved light emitting diode (LED) illuminating assembly is provided with a novel multiple sided LED lighting bar, also referred to as a multi-sided LED light bar, comprising a non-curved LED luminaire for enhanced LED lighting. Advantageously, the inventive LED illuminating assembly with the novel multi-sided light bar is efficient, effective, economical, convenient and safe. Desirably, the user friendly LED illuminating assembly with the compact multi-sided light bar produces outstanding illumination, is easy to manufacture and install, and has a long life span. The improved LED illuminating assembly and attractive multi-sided light bar are also reliable, durable and impact and breakage resistant.

The improved LED illuminating assembly can feature: a multi-sided light bar, such as with two, three, four or five sides; an internal non-switching driver; a scalable length; and an emitter count optimized for efficiency. The improved LED luminaire assembly can also feature: parallel-series wiring; a no-wire design using a unique end cap design; a lens cover cap per design requirements to modify the beam angle; and redundancy in the driver.

There are many advantages of the inventive LED illuminating assembly with a novel multi-sided LED lighting bar comprising a non-curved LED luminaire versus conventional LED lighting.

1. The use of a multi-sided light bar allows for a much wider distribution of light. A standard solution has about 100-110 degree light beam to half brightness. The inventive LED illuminating assembly with the novel multi-sided LED lighting bar, however, can reach a full 360 degrees with little or no loss of brightness. Furthermore, the illustrated two-sided design can reach over 180 degrees to half-brightness. Another advantage is near-field use; lighting something just a few inches from the light source.

2. The internal driver of the improved LED illuminating assembly with the multi-sided lighting bar is less expensive, uses less labor, is simpler and has lower chance of failure over conventional lighting.

3. The non-switching driver of the improved LED illuminating assembly with the multi-sided lighting bar provides a boost of efficiency on the scale of 4-7 magnitude. A typical switching driver which is used on conventional LED lighting bars has a typical efficiency of 80-85% or 15-20% loss. In contrast, the improved LED illuminating assembly with the multi-sided lighting bar can have an efficiency of 95-97% (3-5% loss), and is four to seven times more efficient than conventional lighting. This improvement results in about 20% overall efficiency gain. Since much of the power is spent on the LEDs it takes an increase of 5 times improvement in driver efficiency to net a 20% gain in overall efficiency. Desirably, the improved LED illuminating assembly

with the multi-sided lighting bar can achieve greater than 90% efficiency, an impossibility with conventional switching drivers.

The improved LED illuminating assembly with the multi-sided lighting bar desirably can optimize the emitter count to the voltage source and can advantageously utilize wiring of the emitters in a parallel-series arrangement in the appropriate numbers.

In the improved LED illuminating assembly with the novel multi-sided lighting bar, the diffuser comprising the lens can be modified to change the output of the beam. By use of this arrangement, dark spots can be eliminated so that a much higher illuminating output can be attained. The improved LED illuminating assembly with the multi-sided lighting bar example can emit a 360 degree beam without visible hot or cold spots.

The improved LED illuminating assembly with the multi-sided lighting bar can also have scalable length since there is no theoretical limit to the length of the novel arrangement and design. The length may be governed, however, by customer needs, costs, available space, and production capabilities.

The improved LED illuminating assembly with the multi-sided lighting bar further has driver redundancy using parallel and multiple driver sub-circuits for even better reliability. This achieves two other important goals:

1. The improved LED illuminating assembly with the multi-sided lighting bar attains even, accurate power levels to all emitters. In contrast, conventional LED designs do not control the current to all the emitters evenly, but apply a metered amount of current to all parallel circuits, typically as many as three to eight of them, and the current can vary on each parallel circuit because there is no control per sub-circuit. The improved LED illuminating assembly with the multi-sided lighting bar can control each sub-circuit independently so that every emitter in the entire light assembly gets exactly the same current.

2. The improved LED illuminating assembly with the multi-sided lighting bar achieves reliability of output even in the event of sub-circuit failure.

In a conventional LED design with output 300 mA to three branches or sub-circuits, when one fails, then two sub-circuits will share that same 300 mA so they will go from 100 mA to 150 mA, which is a huge change in current that is not desirable and is likely to cause a cascading failure. In the improved LED illuminating assembly with the multi-sided lighting bar, if one sub-circuit has a failure, the remaining circuits operate exactly as they were, and can operate like that indefinitely.

Furthermore, in the improved LED illuminating assembly with the multi-sided lighting bar, the sub-circuits can be spread out so that no one portion of the light assembly goes completely dark, but will just dim. This can be very important when lighting up a sign so that although it may be a little darker in one spot, the sign will still be lit up and readable.

In conventional LED illumination, all the emitters are in series with each other so in the event of a single LED failure that entire row blinks out (think of Christmas tree lights) and that entire portion of the light assembly will go dark. In the improved LED illuminating assembly with the multi-sided lighting bar, the strings or set of emitters are aligned and connected in parallel with every other emitter so that in the event of failure of one sub-circuit, the LED lamp of the LED illuminating assembly goes to 50% brightness but is evenly lit from edge to edge.

The improved LED illuminating assembly with the multi-sided lighting bar also achieves efficiency over initial capital

costs. Conventional LED designs attempt to maximize lumens per emitter and are designed according to the specification ("spec") of the emitter. Emitters operating 'at spec' tend to net about 80 Lumen/watt total.

The improved LED illuminating assembly with the multi-sided lighting bar can be specifically under-driven to achieve some very valuable goals:

1. Longer life span. For example, an emitter operating at 70% of rated capacity will last 70-80,000 hours when specified at 50,000 hours. That's a difference of 8.6 to 5.7 years when run 24 hours per day at seven days a week.

2. Higher efficacy. The improved LED illuminating assembly with the multi-sided lighting bar can achieve over 100 L/W system total by de-tuning the current drive of the emitter. The improved LED illuminating assembly with the multi-sided lighting bar can achieve the same total output by adding more emitters. This may make the initial cost higher but the operational cost will be much lower. This is shown in the illustrated operational costs chart which compares the high output 3600 L LED light bar to the high efficiency 3000 L LED light bar with the exact same design just set to different drive operating levels because the LEDs that are more efficient and last longer when driven below spec.

3. Higher reliability. Within their expected lifespan, LED emitters will maintain lumen longer and maintain color temperature longer when they are cooler, if the temperature is directly proportional to LED drive current. An over-driven LED will lose color temp accuracy quicker than one driven at 'spec'. An under-driven LED can maintain lumen and color temperature longer than even one driven to 'spec'.

The improved LED illuminating assembly can have a no-wire design such that the novel light bar of the improved LED luminary assembly has no electrical wires. This arrangement can decrease assembly problems and lower failure rate associated with complexity in a manual labor portion of the assembly. A conventional LED light bar can have at least twelve hand-made solder joints. The new design can include only two hand-made solder joints as well as eliminating 100% of the electrical wiring. Elimination of standard electrical wires can increase both initial and long term reliability.

The improved light emitting diode (LED) illuminating assembly can comprise a multiple sided modular LED lighting bar, which is also referred to as a multi-sided modular LED light bar, comprising a non-curvilinear LED luminary with a multi-sided elongated tubular array having multiple, server, numerous or many sides comprising modular boards which can define panels with longitudinally opposite ends. The tubular array preferably has a non-curvilinear cross-sectional configuration (cross-section) without and in the absence of a circular cross-sectional configuration, oval configuration, elliptical cross-sectional configuration and a substantially curved or round cross-sectional configuration. Each of the sides of the multi-sided tubular array can have a generally planar flat surface as viewed from the ends of the array, and adjacent sides can intersect each other and converge at an angle of inclination. Operatively positioned and connected to the multi-sided array can be an internal non-switching printed circuit board (PCB) driver comprising a driver board. The driver, which is optional, as described below, can be an interior or inner driver board positioned within an interior of the tubular array or can be an exterior or outer driver board comprising and providing one of the sides of the tubular array. Desirably, at least two or some of the sides comprise modular LED emitter boards which can provide elongated LED PCB panels. The internal drive comprising the driver board can

drive the LED emitter boards and can comprise one or more modular driver boards that are connected in series and/or parallel to each other.

The improved LED illuminating assembly comprising a multi-sided light bar providing a non-curvilinear (LED) luminary can have an optimal count of LED emitters comprising a group, set, matrix, series, multitude, plurality or array of light emitting diodes (LEDs) securely positioned, mounted and arranged on each of the emitter boards for emitting and distributing light outwardly from the emitter boards in a light distribution pattern for enhanced LED illumination and operational efficiency.

One or more end cap PCB connectors providing connector end boards which are also referred to as end cap boards can be positioned at one or both of the ends of the tubular array and connected to the internal driver board and the emitter boards. The connector end boards can have connector pins which can extend longitudinally outwardly for engaging at least one light socket. One or more end caps can be positioned about the end cap PCB connectors. The end caps can have bracket segments which provide clamps that can extend longitudinally inwardly for abuttingly engaging and clamping the emitter boards.

The boards can have matingly engageable male and female connectors such that the connectors on the connector end boards matingly engage, connect and plug into matingly engageable female and male connectors on the driver board and on the emitter boards.

The boards comprising the emitter boards and driver board can be generally rectangular. Each of the sides of the multi-sided array comprising emitter boards can comprise a single emitter board or a set, series, plurality, or multiple elongated emitter boards that are longitudinally connected end to end. The sides comprising emitter boards can include all of the sides of the tubular array or all but one of the sides of the tubular array with the one other side comprising the driver board. The driver board can comprise a single driver board or multiple driver boards that are longitudinally connected end to end.

A multiple sided tubular heat sink comprising multiple metal sides can be positioned radially inwardly of the multi-sided tubular array for supporting and dissipating heat generated from the emitter boards and drive board. The heat sink can have a tubular cross-section which is generally complementary or similar to the cross-sectional configuration of the multi-sided tubular array. The cross-section of the heat sink preferably can have a non-curvilinear cross-section without and in the absence of a circular cross-section, oval cross-section, elliptical cross-section and a substantially or round curved cross-section.

The improved LED illuminating assembly comprising a multi-sided light bar providing a non-curvilinear (LED) luminary can have emitter traces for connecting the LED emitters in parallel and/or in series and can have alternating current (AC) and/or direct current (DC) lines. The emitters can comprise at least one row of substantially aligned aliquot uniformly spaced LED emitters. Desirably, the multi-sided light bar provides a no-wire design in the absence of electrical wires.

The improved LED illuminating assembly comprising a multi-sided light bar providing a non-curvilinear (LED) luminary can also have a diffuser comprising an elongated light diffuser cover which provides a light transmissive lens positioned about and covering the LED emitters for reflecting, diffusing and/or focusing light emitted from the LED emitters.

In one embodiment, the lighting bar comprises: a two sided lighting bar; the array comprises a two sided array; the heat sink comprise a heat sink with at least two sides; the emitter boards are arranged in a generally V-shaped configuration at an angle of inclination ranging from less than 180 degrees to an angle more than zero degrees; and the driver is positioned in proximity to an open end of the V-shaped configuration.

In another embodiment, the lighting bar comprises: a three sided lighting bar; the array comprises a three sided delta or triangular array; the heat sink comprises a tubular three sided heat sink with a delta or triangular cross-section; and the angle of inclination can range from less than 180 degrees to an angle more than zero degrees, and is preferably about 120 degrees. The driver can be positioned within the interior of the delta or triangular cross-section of the three sided heat sink.

In a further embodiment, the lighting bar comprises: a four sided lighting bar; the array comprises a square or rectangular array; the heat sink comprises a tubular four sided heat sink with a square or rectangular cross-section; and the angle of inclination can be a right angle of about 90 degrees.

In still another embodiment, the lighting bar comprises: a five sided lighting bar; the array comprises a pentagon array; the heat sink comprises a tubular five sided heat sink with a pentagon cross-section; and the angle of inclination of the intersecting sides of the pentagon can comprise an acute angle, preferably at about 72 degrees.

Light bars, arrays and heat sinks with more than five sides can also be used.

The improved LED illuminating assembly can comprise an illuminated LED sign, such as an outdoor sign or an indoor sign. The outdoor sign can comprise an outdoor menu board, such as for use in a drive-through restaurant. The indoor sign can comprise an indoor menu board such as for use in an indoor restaurant. The indoor signs can also be provided for other uses. The illuminated LED sign can comprise: a housing with light sockets; at least one light transmissive panel providing an illuminated window connected to the housing; multiple sided LED lighting bars, which are also referred to as multi-sided light bars, of the type previously described, connected to the light sockets for emitting light through the illuminated window; and the illuminated window can be movable from a closed position to an open position for access to the LED lighting bars. The lighting bars can extend vertically, horizontally, longitudinally, transversely or laterally along portions of the housing. The illuminated window can be covered by a diffuser.

The improved LED illuminating assembly can also comprise an overhead LED lighting assembly providing overhead ceiling lighting with: translucent ceiling panels comprising light transmissive ceiling tiles; at least one drop ceiling light fixture comprising light sockets; and at least one multiple sided LED lighting bar (multi-sided light bar) of the type previously described, connected to the light sockets and positioned above the ceiling panels for emitting light downwardly through the translucent ceiling panels into a room. At least one concave light reflector can be positioned above the LED lighting bar.

In a preferred aspect of the present invention, the luminary is provided in a non-curvilinear or rectilinear shape. In a more preferred aspect, the luminary has a triangular elongated shape. The individual LEDs, a power source, and a mount board are capable of being within or along any of the elongate sides of the luminary.

Advantageously, the improved LED illuminating assembly with a novel multi-sided LED lighting bar comprising a non-curvilinear LED luminary as recited in the patent claims produced unexpectedly surprisingly good results.

The term "non-curvilinear" as used in this application means that the sides are generally flat or planar even if portions of the end caps, end cap connectors or heat sink are curved or rounded.

In one form, the invention is directed to an elongate tubular lighting assembly having a body with a length between spaced first and second ends. The term "tubular" encompasses elongate forms of any cross sectional shape having an interior that is at least partially hollow. The tubular lighting assembly has: a source of illumination on or within the body; and first and second connectors respectively at the first and second body ends that are configured to maintain the body in an operative state on a support for the tubular lighting assembly. The first connector has cooperating first and second parts. The first connector part is at the first end of the body. The second connector part is configured to be on a support for the tubular lighting assembly. The first and second connector parts respectively have first and second surfaces. The first and second connector parts are configured so that the first and second surfaces are placed in confronting relationship to prevent separation of the first and second connector parts with the body in the operative state as an incident of the first connector part moving relative to the second connector part from a position fully separated from the second connector part in a substantially straight path that is transverse to the length of the body into an engaged position.

In one form, the source of illumination is at least one of: a) an LED; and b) a gas-discharge lamp that uses fluorescence to produce visible light.

In one form, the second connector has third and fourth connector parts that are respectively structurally the same as the first and second connector parts and interact with each other at the second end of the body in the same way that the first and second connector parts interact with each other at the first end of the body.

In one form, the first and second connector parts are configured so that the first connector part moves against the second connector part as the first connector part moves toward the engaged position, thereby causing a part of at least one of the first and second connector parts to reconfigure to allow the first and second surfaces to be placed in confronting relationship.

In one form, the first connector part has an opening bounded by an edge. The second connector part has a first bendable part on which the second surface is defined. The second connector part is configured so that the first bendable part: a) is engaged by the edge of the opening and progressively cammed from a holding position, in which the first bendable part resides with the first connector part in the fully separated position, towards an assembly position as the first connector part is moved up to and into the engaged position; and b) moves from the assembly position back towards the holding position with the first connector part in the engaged position.

In one form, the first bendable part is joined to another part of the second connector part through a live hinge.

In one form, the first connector part has a wall through which the opening is formed. The first surface is defined by the wall. The wall has a third surface facing oppositely to each of the first surface and a fourth surface on the second

11

connector part. The wall resides captively between the second and fourth surfaces with the first connector part in the engaged position.

In one form, the second connector part has an actuator. The second connector part is configured so that with the first connector part in the engaged position, the actuator can be repositioned to thereby move the first bendable part towards its assembly position to allow the first connector part to be separated from the second connector part.

In one form, the edge extends fully around the opening.

In one form, the opening and second connector part are configured so that the edge and a surface on the second connector part cooperate to consistently align the second connector part with the opening as the second connector part is directed into the opening as the first connector part is changed between the fully separated position and the engaged position.

In one form, the second connector part has a second bendable part that is configured the same as the first bendable part and cooperates with the edge in the same way that the first bendable part cooperates with the edge in moving between corresponding holding and assembly positions. The first and second bendable parts are movable towards each other in changing from their holding positions into their assembly positions.

In one form, the first connector part is part of a first end cap assembly that is at the first end of the body.

In one form, the first end cap assembly has a first cup-shaped component which defines a first receptacle opening towards the second end of the body into which the first end of the body extends.

In one form, the first end cap assembly further includes at least a first connector board. The source of illumination and at least first connector board are configured to be electrically connected (i.e., connected through a conductive path over which current may flow when the assembly is connected to a power supply) as an incident of the first end of the body and first end cap assembly being moved towards each other in a direction substantially parallel to the length of the body into a connected relationship.

In one form, the first end cap assembly includes a first cup-shaped component which defines a first receptacle opening towards the second end of the body into which the first end of the body extends with the first end of the body and first end cap assembly in the connected relationship.

In one form, the elongate tubular lighting assembly is provided in combination with a power supply electrically connected to the second connector part. There are electrical connector components on the at least first connector board and the second connector part that are configured to be electrically connected as an incident of the first connector part moving from the fully separated position into the engaged position.

In one form, the elongate tubular lighting assembly is provided in combination with a support for the body that has a reflector on which the second connector part is located.

In one form, the second connector part is a component separate from the reflector. The second connector part and reflector are configured so that the second connector part and reflector can be press connected.

In one form, the source of illumination consists of at least one LED emitter panel.

In one form, the first connector part is part of a first end cap assembly that is at the first end of the body. The first end cap assembly includes a first cup-shaped component which defines a first receptacle opening towards the second end of the body into which the first end of the body extends. The

12

third connector part is part of a second end cap assembly that is at the second end of the body. The second end cap assembly has a second cup-shaped component which defines a second receptacle opening towards the first end of the body into which the second end of the body extends.

In one form, the first end cap assembly includes at least a first connector board. The second end cap assembly includes at least a second connector board. The source of illumination and at least first connector board are configured to be electrically connected as an incident of the first end of the body and first end cap assembly being moved towards each other in a direction substantially parallel to the length of the body into a connected relationship. The source of illumination and at least second connector board are configured to be electrically connected as an incident of the second end of the body and second end cap assembly being moved towards each other in a direction substantially parallel to the length of the body into a connected relationship.

In one form, the elongate tubular lighting assembly is provided in combination with a support, on which the second and fourth connector parts are located, and a power supply. The end cap assemblies and first and third connector parts are configured so that as an incident of the first connector part moving from the separated position into the engaged position and the third connector part moving relative to the fourth connector part from a corresponding fully separated position into an engaged position, the second and fourth connector parts secure each of the first and second end cap assemblies and the body in connected relationship.

In one form, the elongate tubular lighting assembly is provided in combination with a light diffuser cover for reflecting, diffusing, and/or focusing light from the source of illumination.

In one form, the invention is directed to an elongate tubular lighting assembly having a body with a length between spaced first and second ends. The tubular lighting assembly has: a source of illumination on or within the body; and first and second connectors respectively at the first and second body ends that are configured to maintain the body in an operative state and the illumination source operatively connected to a power supply. The first connector has cooperating first and second connector parts, one each on the body and a support for the body. Conductive connector components on the first and second connector parts are configured to electrically connect between the source of illumination and a power supply. The first and second connector parts are configured to be held together independently of the conductive connector components to thereby maintain the body in the operative state.

In one form, the elongate tubular lighting assembly is provided in combination with a power supply for the source of illumination.

In one form, the first and second connector parts are configured to be snap-connected to each other and held together as an incident of relatively moving the first and second connector parts towards and against each other.

In one form, the second connector includes third and fourth connector parts that are respectively structurally the same as the first and second connector parts and interact with each other at the second end of the body in the same way that the first and second connector parts interact with each other at the first end of the body.

In one form, the third and fourth connector parts are configured to be snap-connected to each other and held together as an incident of relatively moving the third and fourth connector parts towards and against each other.

13

In one form, the first and second connector parts and third and fourth connector parts are configured to be snap-connected as an incident of the body with the first and third connector thereon moved transversely to the length of the body.

In one form, the first and second connector parts are configured so that the conductive connector components on the first and second connector parts are electrically connected to each other as an incident of the first and second connector parts being snap-connected to each other.

In one form, the first connector part is part of a first end cap assembly. The first end cap assembly and illumination source are configured so that one of the conductive components on the first connector part is electrically connected to the source of illumination as an incident of the first connector part and first end of the body being moved against and relative to each other in a direction substantially parallel to the length of the body.

In one form, the first end cap assembly has a first cup-shaped component into which the first end of the body extends.

In one form, the invention is directed to an elongate tubular lighting assembly having a body with a length between spaced first and second ends. The tubular lighting assembly has: a source of illumination on or within the body; and first and second connectors respectively at the first and second body ends that are configured to maintain the body in an operative state on a support for the tubular lighting assembly. The first connector has cooperating first and second parts. The first connector part is at the first end of the body. The second connector part is configured to be on a support for the tubular lighting assembly. At least one conductive component on each of the first and second connector parts is configured to electrically connect to each other and between the illumination source and a power supply. The illumination source has at least one conductive component. The first connector part, body, and illumination source are configured so that the at least one conductive component on the illumination source is electrically connected to the at least one conductive component on the first connector part as an incident of the first connector part and first end of the body moved from an initially fully separated state towards and against each other.

In one form, the second connector has third and fourth connector parts that are respectively structurally the same as the first and second connector parts and interact with each other at the second end of the body in the same way that the first and second connector parts interact with each other at the first end of the body.

In one form, the first and second connector parts, body, and illumination source are configured so that: a) the at least one conductive component on the illumination source is electrically connected to the at least one conductive component on the first connector part; and b) at least another conductive component on the illumination source is electrically connected to at least another conductive component on the third connector part as an incident of the body and first and third connector parts being moved towards and against each other in a direction substantially parallel to the length of the body.

In one form, the first connector part is part of a first end cap assembly having a first cup-shaped component opening towards the second end of the body into which the first end of the body extends.

In one form, the third connector part is part of a second end cap assembly having a second cup-shaped component

14

opening towards the first end of the body into which the second end of the body extends.

In one form, the elongate tubular lighting assembly is provided in combination with a support on which the second and fourth component parts are located. With the body in the operative state, the first and second cup-shaped components reside captively between the second and fourth connector parts so that the first and second cup-shaped components are blocked from being separated respectively from the first and second ends of the body.

BRIEF DESCRIPTION OF THE DRAWINGS

FIG. 1 is a perspective view of an LED drop ceiling fixture with three sided delta non-curvilinear LED luminaries mounted to a ceiling above ceiling panels in accordance with principles of the present invention;

FIG. 2 is an enlarged view of portions of the LED drop ceiling fixture with three sided delta non-curvilinear LED luminaries of FIG. 1;

FIG. 3 is a cross-section view of the LED drop ceiling fixture with three sided delta LED non-curvilinear luminaries of FIG. 1;

FIG. 4 is an enlarged perspective view of the three sided delta LED luminaries of FIG. 1;

FIG. 5 is a perspective view of a four sided rectangular or square non-curvilinear LED luminary in accordance with principles of the present invention;

FIG. 6 is a perspective view of a five sided pentagon non-curvilinear LED luminary in accordance with principles of the present invention;

FIG. 7 is an enlarged cross-sectional view of the five sided pentagon noncurvilinear LED luminary of FIG. 6;

FIG. 8 is a perspective view of an outdoor menu board providing an outdoor sign with two sided delta non-curvilinear LED luminaries such as for drive through menu board applications and illustrating the menu board door partially open in accordance with principles of the present invention;

FIG. 9 is an enlarged view of portions of the outdoor menu board of FIG. 8;

FIG. 10 is a perspective view of an indoor menu board providing an indoor sign with three sided delta non-curvilinear LED luminaries such as for a restaurant, and illustrating one of the panel doors in a partially open position in accordance with principles of the present invention;

FIG. 11 is an enlarged view of portions of the indoor menu board of FIG. 10;

FIG. 12 is an exploded assembly view of a three sided delta non-curvilinear LED luminary in accordance with principles of the present invention;

FIG. 13 is an enlarged view of the right portions of the three sided delta noncurvilinear LED luminary of FIG. 12;

FIG. 14 is an enlarged view of the left portions of the three sided delta noncurvilinear LED luminary of FIG. 12;

FIG. 15 is an exploded assembly view of a two sided non-curvilinear LED luminary in accordance with principles of the present invention;

FIG. 16 is an enlarged view of the right portions of the two sided noncurvilinear LED luminary of FIG. 15;

FIG. 17 is an exploded assembly view of another two sided non-curvilinear LED luminary in accordance with principles of the present invention;

FIG. 18 is an enlarged view of the right portions of the two sided noncurvilinear LED luminary of FIG. 17;

FIG. 19 is a perspective view of an end cap connector board for a two sided delta non-curvilinear LED in accordance with principles of the present invention;

15

FIG. 20 is a perspective view of surface mount connectors connected to the end cap connector board of FIG. 19;

FIG. 21 is a perspective view of a portion of a driver board connected to the surface mount connectors connected of FIG. 20;

FIG. 22 is a perspective view of a portion of a three sided delta heat sink tube positioned peripherally about the driver board and against the end cap connector board of FIG. 21;

FIG. 23 is a perspective view of emitters on an emitter board with AC and DC power traces connected to the surface mount connectors and positioned about the heat sink tube of FIG. 22;

FIG. 24 is a perspective view of a portion of a lens about the emitters of FIG. 23;

FIG. 25 is a perspective view of a portion of an end cap at the left end of the lens of FIG. 24;

FIG. 26 is a perspective view of the two sided delta non-curvilinear LED luminary with the end cap and showing portions of the lens removed to illustrate the emitters on the emitter board and the AC and DC power traces connected to the surface mount connectors;

FIG. 27 is a perspective view of an end cap connector board or connector end board and driver board for a two sided delta non-curvilinear LED luminary in accordance with principles of the present invention;

FIG. 28 is a perspective view of emitter board connectors connected to the end cap connector board and illustrating driver connectors connected to the driver board and the end cap connector board of FIG. 27;

FIG. 29 is a perspective view of LED emitters mounted on an emitter board about a heat sink tube and against the end cap connector board of FIG. 28 and illustrating traces and jumpers;

FIG. 30 is a front view of the end cap connector board of FIG. 27;

FIG. 31 is a perspective view of emitter boards which are connected longitudinally end to end for use in the non-curvilinear LED luminaries in accordance with principles of the present invention;

FIG. 32 is a perspective view of LED emitters mounted on the emitter boards of FIG. 31 and illustrating the emitter board connectors;

FIG. 33 is a schematic delta LED wiring diagram for the three sided delta noncurvilinear LED luminary in accordance with principles of the present invention;

FIG. 34 is a light distribution pattern emitted from a straight row of emitters and is sometime referred to as the "baseline" or "light angle before";

FIG. 35 is a light distribution pattern emitted from a two sided delta noncurvilinear LED luminary in accordance with principles of the present invention and is sometimes referred to as the "light angle after";

FIG. 36 is a light distribution pattern emitted from a conventional prior art flat plane of forward facing emitters with the four light bars spaced six inches apart in one or four rows and is sometime referred to as the "light array before";

FIG. 37 is a light distribution pattern emitted from four light bars of two sided delta non-curvilinear LED luminaries in accordance with principles of the present invention and is sometime referred to as the "light array before";

FIG. 38 is a light distribution pattern emitted from a conventional prior art setup using two planar row of emitters back-to-back at 180 degrees such as for illuminating a two sided outdoor sign;

FIG. 39 is a light distribution pattern emitted from three sided delta noncurvilinear LED luminaries in accordance with principles of the present invention and is optimized to

16

reduce the dim zone on the forward facing sided as well as create a balance between two dark zone that are mostly going into a reflector and the one zone that is used for direct illumination;

FIG. 40 is a light distribution pattern emitted from a single emitter;

FIG. 41 is a light distribution pattern emitted from a set or row of emitter of FIG. 40;

FIG. 42 IS a light distribution pattern emitted from a single forward facing emitter;

FIG. 43 is a light distribution pattern emitted from a set or row of forward facing emitters of FIG. 4;

FIG. 44 is a graph of operational costs of non-curvilinear LED luminaries in accordance with principles of the present invention in comparison with conventional LED and fluorescent luminaries where the X axis is time in years and the Y axis is U.S. dollars (USD).

FIG. 45 is a schematic diagram of a prototype non-curvilinear LED luminary in accordance with principles of the present invention;

FIG. 46 is a top view of the prototype non-curvilinear LED luminary of FIG. 45;

FIG. 47 is a schematic diagram of another prototype non-curvilinear LED luminary in accordance with principles of the present invention;

FIG. 48 is an enlarged cross-sectional view of a prototype delta three sided noncurvilinear LED luminary in accordance with principles of the present invention and taken along line A-A of FIG. 47;

FIG. 49 is a bottom view of the non-curvilinear LED taken along line B of FIG. 48;

FIG. 50 is an enlarged cross-sectional view of a further prototype delta three sided non-curvilinear LED luminary in accordance with principles of the present invention;

FIG. 51 is a perspective view of part of the prototype delta three sided noncurvilinear LED luminary of FIG. 50;

FIG. 52 is a perspective view of pin arrangements in lamp bases for compact lamp shapes;

FIG. 53 illustrates the front and bottom views of pin arrangements in compact lamp bases for two pin lamps;

FIG. 54 illustrates the front and bottom views of pin arrangements in compact lamp bases for four pin lamps;

FIG. 55 is a fragmentary, exploded, perspective view of one end of a conventional tubular lighting assembly with a connector on a body having an illumination source and a cooperating connector on a support;

FIG. 56 is a view as in FIG. 55 with the body aligned for installation;

FIG. 57 is a view as in FIG. 56 and showing cooperating connectors at the opposite end of the body and on the support;

FIGS. 58 and 59 correspond respectively to FIGS. 56 and 57 and show the body pushed upwardly to engage the cooperating connectors;

FIGS. 60 and 61 correspond respectively to FIGS. 58 and 59 and show the tube turned to lock the tube in place through the cooperating connectors;

FIG. 62 is a fragmentary, perspective view of an elongate tubular lighting assembly, according to the invention, and showing cooperating connector parts at one end of a body on or within which there is a source of illumination;

FIG. 63 is a view as in FIG. 62 with the connector parts fully separated from each other;

FIG. 64 is a view as in FIG. 63 showing cooperating connector parts at the opposite end of the body;

FIGS. 65 and 66 correspond respectively to FIGS. 63 and 64 and show the connector parts snap-fit together;

17

FIG. 67 corresponds to FIGS. 63 and 64, reduced in size, and taken together to show the entire body;

FIG. 68 is a view as in FIG. 67 and corresponds to FIGS. 65 and 66, taken together, to show the entire body;

FIG. 69 is a view as in FIG. 68 with a diffusion cover removed to expose the source of illumination;

FIG. 70 is an exploded, perspective view of the tubular lighting assembly in FIG. 69;

FIG. 70a is a schematic representation of a connector board at one end of the body that is an alternative to the two boards used at the same end of the body in FIG. 70;

FIG. 71 is an enlarged, perspective view of an end cap assembly consisting of the connector parts in FIG. 65 and connector boards for the source of illumination;

FIG. 72 is an exploded, perspective view of the components in FIG. 71;

FIG. 72a is a view as in FIG. 72 but from a different perspective and with a part of one of the connector parts broken away;

FIG. 72b is a view as in FIG. 72a with the parts assembled;

FIG. 73 is an exploded view of the components in FIG. 72 from a different perspective;

FIG. 74 is an enlarged, end view of the connector parts shown in the relationship of FIG. 63;

FIG. 75 is a view as in FIG. 74 with the connector parts in the relationship of FIG. 65;

FIG. 76 is a view as in FIG. 73 from a different perspective;

FIG. 77 is a view as in FIG. 76 with the connector parts joined as in FIG. 69;

FIG. 78 is a schematic representation of a tubular lighting assembly, according to the invention;

FIG. 79 is a view as in FIG. 72 and showing a modified form of one of the connector parts to cooperate with a cylindrical body;

FIG. 80 is a view as in FIG. 79 with the connector parts snap-fit together;

FIG. 81 is a schematic representation of a modified form of tubular lighting assembly, according to the invention;

FIG. 82 is a schematic representation of a further modified form of tubular lighting assembly, according to the invention;

FIG. 82a is an exploded, perspective view corresponding generally to the tubular lighting assembly of FIGS. 69 and 70, but with the connector components and connector board eliminated at one end, as shown in the schematic representation of FIG. 82, according to the invention;

FIG. 83 is an end view of part of another modified form of body in a tubular lighting assembly, according to the invention;

FIG. 84 is a view as in FIG. 83 of a further modified form of body, according to the invention;

FIG. 85 is a view as in FIG. 84 with a diffuser cover situated in a pre-assembly position relative to a heat sink; and

FIG. 86 is a view as in FIG. 84 of a still further modified form of body, according to the invention.

FIG. 87 is an exploded, perspective view of a modified form of the tubular lighting assembly with an uninterrupted power supply positioned within the heat sink, according to the invention.

A more detailed explanation of the principles of the invention is provided in the following detailed descriptions

18

of example embodiments thereof, taken in conjunction with the accompanying drawings, briefly described above.

DETAILED DESCRIPTION OF THE PREFERRED EMBODIMENTS

The following is a detailed description and explanation of the preferred embodiments of the invention and best modes for practicing the invention.

Referring to the drawings, FIG. 1 is a perspective view of a light emitting diode (LED) light illuminating assembly 100 comprising an overhead LED lighting assembly providing overhead ceiling lighting with a two by four (2x4) LED drop ceiling fixture 101 with a multiple sided modular LED lighting bars 102, which are also referred to a multi-sided LED light bars. The lighting bars can comprise three sided delta triangular shaped non-curvilinear light emitting diode (LED) luminaries 103 which can be mounted to a ceiling 104, such as by power connector pins 106 extending from three sided delta triangular shaped end caps 108 which can securely engage light sockets 110. FIG. 2 is an enlarged view of portions of the multi-sided LED lighting bar comprising a LED drop ceiling fixture with three sided delta non-curvilinear LED luminaries of FIG. 1. Upright metal side members 112 can provide a bracket which can integrally extend between and connect the light sockets to overhead metal concave light reflectors 114. The light reflectors can be positioned above the three sided delta non-curvilinear LED luminaries to reflect light downwardly towards a floor. The three sided delta non-curvilinear LED luminaries, sockets and reflectors can be positioned above light transmissive translucent ceiling panels 116 (FIG. 1) providing light transmissive ceiling tiles arranged in a grid or pattern. The ceiling tiles can comprise an elongate light diffuser 117 providing a light transmissive lens for diffusing and/or focusing light emitted from the LED emitted on towards the floor. The ceiling panels can be connected by a ceiling grid 118 of longitudinal and lateral rows of ceiling panel-connectors 120. FIG. 3 is a cross-section view of the LED drop ceiling fixture with three sided delta LED non-curvilinear luminaries and illustrating elongated LED emitter printed circuit board (PCB) panels 122, which are also referred to as modular LED emitter boards. The LED PCB panels can be mounted or otherwise secured upon and/or positioned radially outwardly of the sides of an elongated three sided, delta or triangular tubular metal heat sink 124 (FIG. 1) to form a three sided delta or triangular array or set of emitter boards. The intersecting sides of the three sided heat sink can provide corners and apexes of the heat sink which sink can be raised, rounded, or chamfered, if desired. An internal non-switching PCB 125 comprising a driver board can be positioned in the interior of the array to drive the emitter boards. FIG. 4 is an enlarged perspective view of the three sided delta LED luminaries. Each of the three sided LED emitter PCB panels can contain a set, matrix or array of one or more rows of aligned, aliquot, uniformly spaced LED emitters 126. The heat sink can comprise an aluminum extrusion and can dissipate heat generated by the LED emitters and driver.

FIG. 5 is a perspective view of a LED illuminating light assembly 130 comprising a four sided modular LED lighting bar 131 (LED light bar) providing a four sided rectangular or square non-curvilinear LED luminary 132 which can have end caps 133 and outwardly extending power connector pins 134 for securely engaging a light socket. The four sided LED luminary can have an elongated four sided tubular metal heat sink 136, such as formed from an aluminum extrusion.

19

The intersecting side of the four sided heat sink can provide corners and apexes **137** of the heat sink which can be raised, rounded, curved or chamfered, if desired. Elongated LED emitter PCB panels **138** providing modular emitter boards can be mounted or otherwise secured upon and/or positioned radially outwardly of the heat sink in a generally rectangular shaped array. Each of the LED emitter PCB panels can be rectangular and can contain one or more rows of aligned, aliquot, uniformly spaced LED emitters **140**. The heat sink can dissipate heat generated by the LED emitters. Terminals **142** can be connected to an end cap printed circuit board (PCB) connector **144** comprising a connector end board which is also referred to as an end cap board that can be fastened by screws **146** to the end cap. An internal non-switching PCB driver comprising a driver board can be positioned in the interior of the array to drive the emitter boards.

FIG. **6** is a perspective view of a LED illuminating assembly **150** comprising a five sided modular LED lighting bar **151** (LED light bar) providing a five sided pentagon shaped non-curvilinear LED luminary **152**. The luminary can have end caps **153** and outwardly extending power connector pins **154** for securely engaging a light socket. The five sided LED luminary can have an elongated five sided pentagon shaped tubular metal heat sink **156**, such as formed from an aluminum extrusion. The intersecting sides of the pentagon heat sink provides corners and apexes **157** of the heat sink which can be raised, rounded, curved or chamfered, if desired. Elongated LED emitter PCB panels **158**, also referred to as modular LED emitter boards, can be mounted or otherwise secured upon and/or radially outwardly of the heat sink to form a five sided pentagon array of LED emitter PCB panels. Each of the five sided LED emitter PCB panels can be rectangular and contain one or more rows of aligned, aliquot, uniformly spaced LED emitters **160**. Terminal(s) **162** can be connected to an end cap PCB connector **164** comprising a connector end board which is also referred to as an end cap board which can be fastened by screws **166** to the end cap. FIG. **7** is an enlarged cross-sectional view of the five sided pentagon non-curvilinear LED luminary. An internal non-switching PCB driver **168** comprising a driver board can be positioned in the interior of the array to drive the emitter boards. The heat sink can dissipate heat generated by the LED emitters and driver.

FIG. **8** is a perspective view of an LED illuminating assembly **170** comprising an elongated outdoor menu board **171** which can provide an outdoor sign **172** with two sided modular LED lighting bars **173** (LED light bars) comprising two sided or delta non-curvilinear LED luminaries **174** such as to drive through menu board applications. FIG. **8** also illustrates the front menu board door **176** partially open. The front menu board can comprise a rectangular frame **178** to peripherally surround and secure light transmissive panel(s) **180** which can provide a door plex comprising an illuminated menu window **182**. The menu window can provide illuminated signage which can comprise an elongated light diffuser **183** that can provide a light transmissive lens for diffusing and/or focusing light emitted from the LED outwardly. The front menu board door can be pivotally hinged or removably attached to the top **184** or one of the sides **186** of the outdoor menu board housing **188**. The back of the housing can also have a light transmissive panel(s), if it is desired to illuminate both the front and back of the outdoor menu board. The two sided delta non-curvilinear LED luminaries can be connected, such as by power connector pins, to light socket assemblies **190**. The two sided delta non-curvilinear LED luminaries can be positioned vertically,

20

longitudinally, laterally, transversely, or horizontally in the interior of the outdoor menu board housing. A menu board vertical upright support post **192**, which can have a rectangular, square, or rounded cross section, can be mounted on a base plate and connected to the top of the menu board housing along the vertical centerline of the housing, to support and elevate the outdoor menu board housing, door and illuminated menu window. FIG. **9** is an enlarged view of portions of the outdoor illuminated menu board.

FIG. **10** is a perspective view of LED illuminating assembly **200** comprising an elongated indoor menu board **201** providing a wall mounted indoor sign **202** with two or three sided modular LED lighting bars **203** (LED light bars) comprising two or three sided delta non-curvilinear LED luminaries **204** for use such as in, but not limited to a restaurant **206** with a counter **208**, walls **210-213**, exit and/or entrance door **214** and a counter **214** and illustrating one of the menu panel doors **216** in a partially open position. FIG. **11** is an enlarged view of portions of the indoor menu board. The back **218** of the menu board can be securely mounted on a wall. The front of the menu board can comprise one or more menu panel doors such as a set or array of horizontally aligned menu panel doors. Each menu panel door can comprise a rectangular frame **220** to peripherally surround and secure a light transmissive panel **222** which can provide a door apex comprising an illuminated menu window **224**. The menu window can provide illuminated signage which can comprise an elongated light diffuser **225** that can provide a light transmissive lens for diffusing and/or focusing light emitted from the LED outward into the room or interior of the restaurant. Each menu board panel door can be pivotally hinged or removably attached to the top **226** or one of the sides **228** of the menu board housing **230**. The two or three sided delta non-curvilinear LED luminaries can be connected, such as by power connector pins, to light socket assemblies **232**. The two sided delta non-curvilinear LED luminaries can be positioned vertically, longitudinally, laterally, transversely or horizontally in the interior of the outdoor menu board housing.

FIG. **12** is an exploded assembly view of LED illuminating assembly **240** comprising a three sided modular LED lighting bar **241** (LED light bar) providing a three sided delta or triangular shaped non-curvilinear LED luminary **242**. FIG. **13** is an enlarged view of the right portions of the three sided delta non-curvilinear LED luminary of FIG. **12**. FIG. **14** is an enlarged view of the left portions of the three sided delta non-curvilinear LED luminary of FIG. **12**. The three sided delta non-curvilinear LED luminary can have a three sided delta triangular shaped metal heat sink **243**, such as formed from extruded aluminum. The intersecting corners **244** providing apexes of the heat sink can be raised, rounded or chamfered, if desired. Elongated LED emitter PCB panels **246-248** can be mounted or otherwise secured upon and/or positioned radially outwardly of the heat sink in a generally triangular or delta shape. Each of the LED emitter PCB panels can be rectangular and can contain one or more rows of aligned, aliquot, uniformly spaced modular LED emitters **250**. An internal non-switching elongated printed circuit board (PCB) driver **252**, also referred to as a driver board, can be positioned along the length of and within the interior area bounded by the heat sink. The heat sink can dissipate heat generated by the LED emitters and PCB driver. Emitter board terminals **254-256** can extend longitudinally outwardly from the LED emitter boards. Driver board terminals **258** can be extended longitudinally outwardly from the PCB driver. The three sided delta triangular shaped non-curvilinear LED luminary can have three sided delta end cap PCB

connectors **260-261** comprising connector end boards which are also referred to as end cap boards that can be secured to three sided delta or triangular shaped end caps **262-263**, respectively, by fasteners **264**, such as screws, through screw holes **265** in the end caps. The end caps can have rounded corners **266** or apexes. Power connector pins **268** can extend laterally outwardly from the connector end boards through connector pin-receiving holes **270** in the end caps for secure engagement with a light socket. The connector end boards can have end cap board terminals **272** which extend longitudinally inwardly along its three sides which can connect to the emitter board terminals. The connector end boards can also have a driver board connecting terminals **274** which extends longitudinally inwardly from central portions of the connector end boards and can be connected to the drive board terminals. A three sided delta or triangular shaped covers **276** can provide rims for positioning about the end caps. As best shown in FIG. **14**, the connector end boards can each have a central U-shaped concave notched portion **278** between two of the sides **280** and **282** and can have a lower third side **284** which extends below the lower portions of the other two sides. The sides **280-284** can be straight, flat and planar.

FIG. **15** is an exploded assembly view of a LED illuminating assembly **290** comprising a two sided modular LED lighting bar **291** (LED light bar) providing a two sided elongated non-curvilinear LED luminary **292** which is similar to the three sided delta or triangular shaped non-curvilinear LED luminary of FIGS. **12-14** except there are only two elongated LED emitter PCB panels **293** comprising modular LED emitter boards which can be mounted or otherwise secured upon and/or positioned radially outwardly of the two sides **294** and **295** of the three sides **294-296** of the three sided delta or triangular shaped metal heat sink **297**. The two LED emitter panels can be positioned in a generally V shape. FIG. **16** is an enlarged view of the right portions of the two sided non-curvilinear LED luminary of FIG. **15**. Each of the LED emitter PCB panels can be rectangular and can contain one or more rows of aligned, aliquot, uniformly spaced LED emitters **298**. An internal non-switching elongated printed circuit board (PCB) driver **300** can be positioned along the length of and within the interior area bounded by the heat sink. The heat sink can dissipate heat generated by the LED emitters and PCB driver. Emitter board terminals **302** and **304**, which are also referred to as emitter board connectors, can extend longitudinally outwardly from the LED emitter boards. Driver board terminals **306** can extend longitudinally outwardly from the PCB driver. The two sided delta triangular shaped non-curvilinear LED luminary can have three sided delta or triangular connector end boards **308** and **310** comprising connector end boards which can be secured to three sided delta or triangular shaped end caps **312** and **314**, respectively, by fasteners **316**, such as screws, through screw holes **318** in the end caps. Power connector pins **320** can extend laterally outwardly from the connector end boards through connector pin-receiving holes **322** in the end caps for secure engagement with a light socket. The connector end boards can have end cap board terminals **324**, which are also referred to as surface mount connectors, that can extend longitudinally inwardly along two of its three sides and can be aligned with and connect to the emitter board terminals. The connector end boards can also have a driver board connecting terminals **326** which extends longitudinally inwardly from central portions of the PCB end cap connector boards and can be connected to the driver board terminals. An elongated light diffuser cover **328** comprising a

concave translucent or transparent light transmissive lens can cover the LED emitter boards for reflecting, diffusing and/or focusing light emitted from the LED emitters. The lens can be formed of plastic or glass and can be rounded, semicircular and positioned radially outwardly of the LED emitters. The lens can have inward facing feet **329** which can snap fit about the heat sink.

FIG. **17** is an exploded assembly view of a LED illuminating assembly **330** comprising a two sided modular light bar **331** providing another two sided non-curvilinear LED luminary **332** which is similar to the two sided non-curvilinear LED luminary of FIGS. **15-16** except that there are two sets or arrays **333** of elongated LED emitter PCB panels comprising modular LED emitters which can be mounted or otherwise secured upon and/or positioned radially outwardly of the two sides of the three sided delta or triangular shaped metal heat sink **334**. FIG. **18** is an enlarged view of the right portions of the two sided non-curvilinear LED luminary of FIG. **17**. Each of the sets or arrays of modular LED emitter PCB panels have more than one LED emitter PCB panel, such as but not limited to, three elongated LED emitter PCB panels **336-338** providing modules which extend and are aligned and connected, lengthwise and longitudinally end to end via emitter PCB panel terminal connectors **340** and **342**. Each of the LED emitter PCB panels can be rectangular and can contain one or more rows of aligned, aliquot, uniformly spaced LED emitters **343**. The LED luminary can have three sided delta or triangular end cap connectors **344** which comprise connector end boards that can be secured to three sided delta or triangular shaped end caps **346** by screws or other fasteners through screw holes **348** in the end caps. Power connector pins **350** can extend laterally outwardly from the connector end boards through connector pin-receiving holes in the end caps for secure engagement with end plugging into a light socket. The connector end boards can have end cap board terminals **352** which can extend longitudinally inwardly along two of its three sides and can connect to the emitter board terminals. An elongated translucent or transparent light transmissive plastic lens **354** comprising a diffuser cover of diffuser can cover the LED emitter boards. The lens can be rounded, semicircular and positioned radially outwardly of the LED emitters. The lens can have inward facing feet **356** which can snap fit about the heat sink.

FIG. **19** is a perspective view of an end cap PCB connector **360**, also referred to as a connector end board or end cap board, for a LED illuminating assembly comprising a two sided LED bar providing a two sided delta or triangular non-curvilinear LED luminary, such as shown in FIGS. **15-16**. The end cap PCB connector can have a central U-shaped concave notched portion **362** between two of the sides comprising convex curved arcuate sides **364** and **366** and can have a lower third side, comprising a straight flat planar side **368** which can extend below the lower portions of the two convex sides. The PCB connector can have connector pin-holes **370**, also referred to as AC power pin connectors or AC hot pin connector, as well as electrical traces **372** for connecting the electrical components on the end cap PCB connector. As shown in FIG. **20**, surface mount connectors **374-376**, which are also referred to as emitter board connectors or end cap board terminals, can be connected alongside portion of the connector end board in proximity to the sides of the connector end board. The surface mount connectors of the end cap PCB connector can be connected to drive board connectors **378** (FIG. **21**), also referred to as PCB driver connectors, of an internal non-switching elongated driver board **380** comprising a driver. A

three sided delta or triangular shaped metal heat sink tube **382** (FIG. 22), also referred to as a tubular heat sink, can be positioned peripherally about the driver board and against the cap connector end board. The heat sink can have upwardly facing emitter board-supporting channels **384** and **386** along its bottom edges to support elongated LED emitter PCB panels **388** (FIG. 23), which are also referred to as modular LED emitter boards. The LED emitter PCB panels can be mounted or otherwise secured upon and/or be positioned radially outwardly of the heat sink to form a V-shaped array. Each of the LED emitter PCB panels can contain one or more rows of aligned, aliquot, uniformly spaced LED emitters **390**. The heat sink can dissipate heat generated by the LED emitters and driver board. Emitter board connectors **392**, which are also referred to as emitter board terminals, can extend from the ends of the emitter boards and connect to the surface mount connectors comprising end cap board terminals of the end cap PCB connector. Emitter traces **394** can connect the LED emitters in series while end traces **396** can connect the emitters to the emitter board connectors. An alternating current (AC) power trace **398** can be positioned in parallel to an extra trace **399** and a direct current (DC) trace **400** on the emitter board. An elongated translucent or transparent light transmissive lens **402** (FIG. 24) comprising a diffuser cover or diffuser can cover the LED emitter boards. The lens can be rounded, semicircular and/or positioned radially outwardly of the LED emitters. The elongated longitudinal lower ends **404** of the lens can comprise feet and can fit in and be supported by channels of the heat sink. End caps **406** (FIG. 25) can be positioned about the ends of the lens and end cap PCB connectors. FIG. 26 is a perspective view of the three sided delta or triangular non-curvilinear LED luminary with the end cap and showing portions of the lens removed to illustrate the emitters on the emitter board and the AC and DC power traces connected to the surface mount connectors. As shown in FIG. 26, the end caps can have arcuate curved concave brackets **408** comprising bracket segments which can extend longitudinally inwardly and can provide clamps positioned about portions of the periphery of the end caps to securely engage, grasp, snap fit, clamp and hold the top ends of the emitter boards.

AC traces **410** (FIG. 27) and DC traces **412** can be connected to driver circuitry **414** on the driver board **380**. Driver connectors **378** (FIG. 28) can be connected to the driver circuitry as well as to the surface mount connectors **375**, also referred to as emitter board connectors, of the end cap PCB connector (connector end board or end cap board) **372**. In some arrangements, the end cap connector board can have male connectors **377** with longitudinally inwardly extending connector pins **379** to matingly engage and plug into female connectors on the emitter boards and/or driver board and the end cap connector board can have female connectors **374** to receive and plug into the longitudinally outwardly connector pins of matingly engageable (mating) male connectors on the emitter board and/or driver board. In the illustrated embodiment, there are a four pin connectors at end of each emitter board and driver board, although for some longer light bars, it may be desirable to use six pin connectors.

The end cap PCB connector can have DC power terminals **416** (FIG. 30) to conduct direct current (DC) to three LED strings as well as DC return terminals **418** to receive DC from the LEDs. An AC neutral trace **420** can extend from the opposite side. The end cap PCB connector can also have an AC neutral terminal **422** and an AC hot terminal **424**.

FIG. 29 is a perspective view of LED emitters mounted on a modular LED emitter board about a heat sink tube (tubular heat sink) and against the end cap connector. The emitter can have an extra trace **426** connected to the emitter board connectors to carry either AC or DC from the opposite side or end of the emitter board. The emitter board can also have regulated DC return traces **428** connected to the emitter board connectors and to series-parallel jumpers **430**. The drawings show how the driver is connected to the connector end board in a delta two-sided configuration with both male and female connectors. In some arrangements, (modules), only one end cap board is needed and the emitter boards are designed within a built in electric loop which sends electrical signals through both emitter boards in a W configuration.

The end cap board can have power pins directly soldered without wires. The driver board can be directly socketed and positioned inside the tube (tubular array). Each of the emitter boards can be directly socketed without wires. Extra traces are utilized when necessary to eliminate the need for a main power wire running through the tube (heat sink).

FIG. 31 is a perspective view of modular emitter boards **432** and **434** which are connected longitudinally end to end, such as described in FIGS. 17 and 18. The emitter boards can have printed emitter board circuitry **436** and sub-circuitry **438**. FIG. 32 is a perspective view of LED emitters **390** and series-parallel jumpers **430** mounted on the emitter boards and illustrating emitter board connectors **440** and **442** comprising emitter PCB panel terminal connectors which can connect the ends of the emitter boards.

FIG. 33 is a schematic delta LED wiring diagram for a LED illuminating assembly comprising a three sided LED lighting bar (LED light bar) providing the three sided delta or triangular shaped non-curvilinear LED luminary. The luminary can have three sides comprising rows **450-452** of modular LED emitter boards. Each row can be connected by emitter end traces **454-459** in parallel to end cap PCB connectors (connector end boards or end cap boards) **460** and **462**. Each row of LED emitter boards can comprise three aligned modular LED emitter boards **464-466** which can be connected in series to each other by emitter serial traces **468** and **470**. The emitter end traces can comprise independent DC regulated return lines (traces) **457-459** which can be connected in parallel to a driver board **472**. A common DC outlet line (trace) **474** can be connected to the driver board in parallel with the independent DC regulated return lines. The common DC out line can be connected and extend through the end cap PCB connector **462** through the LED emitter boards of bottom row **452** to end cap PCB connector **460** and in parallel to emitter end traces **454-456**. AC line (trace) **476** can extend from the driver board to the end cap **462** and outwardly, such as but not limited to another electrical component or an AC power source. An extra AC line (trace) **478** can extend from the driver board through the end cap PCB connector **462** and top row **450** of LED emitter boards to the end cap PCB connector **460** to eliminate the need of a wire to carry AC. The wiring diagram can include parallel paths on every emitter board allowing many variations of parallel-series electrical connections, such as by using jumpers on the emitter boards.

The wiring diagram of FIG. 33 illustrates the elimination of all wires. While the drawing shows what appears to be a jumper cable between the driver and end-cap, there is only a connector, because they are directly connected. More specifically, alternating current (AC) comes in on the two end-caps; the 'hot' on one side and 'neutral' on the other side. One side of the AC is fed along one string of emitter boards to the main end cap (shown on the right of FIG. 33),

where it meets up with the other half of the AC and is fed to the driver board. The driver board converts the AC to direct current (DC) and sends DC current on one trace to the secondary end-cap through an extra trace on one row of emitter boards, where it is combined to apply the same high voltage DC to each string of emitters. On the low side of each string of emitters, there is an independent trace returning to the driver which has an independent current-controlling driver that controls the current separately to each string of emitters with high precision. The wiring diagram is simplified, because in reality there are multiple traces through each emitter board, so that any board can be assigned to any sub-driver.

The wiring diagram shows an example with three strings of three emitter boards: driver portion "a" running the top three emitter boards, driver portion "b" the middle three emitter boards and driver portion "c" the bottom three emitter boards, however for ultimate in redundancy, they can actually be wired such that the driver is responsible for three boards and will not light up emitter boards next to each other.

Example. In this case, the emitter board: driver combination:

AAA
BBB
CCC

if sub-driver A, B or C fails, or any emitter in the string, one third of the light goes away on that whole side. However, the real wiring would look like this:

ABC
CAB
BCA

Now if or when one driver sub circuit fails, two-thirds of the light remains and the dead spot revolves around the lamp so there is only a dim spot and not a black out.

Parallel traces can be used in the preferred arrangement. The boards can be made with the traces pre-fabricated. Parallel traces are utilized when needed to get the power to the emitters in an electrically efficient way. The advantage of using parallel traces means is the emitters are all driven at exactly the same current and power level. That is not the case in most conventional designs. A further advantage of the arrangement of parallel-series wiring is that we can run our lighting at higher voltage and lower current so that it is more efficient regardless of which driver is used. This is an important aspect of this arrangement. Furthermore, a multiple channel driver that has multiple channels can be used. In one particular model, six boards were wired three different ways.

Light distribution patterns are shown in FIGS. 34-43. FIG. 34 is a light distribution pattern emitted from a straight row of emitters and is sometime referred to as the "baseline" or light angle before". The full angle is about 150 degrees of usable light but the fall-off is down to 20% of peak brightness on the outer edges of that cone of light. The Y2 brightness angle (angle outside of which is less than Y2 the peak on axis intensity) is about 120 degree in a very good emitter (60 degrees off-axis in a 360 degree cone). When using rows of emitters in columns with the rows representing the PCB and the columns representing the light bar, the light distribution is uneven as the columns are spread out, since due to practicality, the spacing on the rows will be closer than on the column.

FIG. 35 is a light distribution pattern emitted from a two sided delta non-curvilinear LED luminary and is sometime referred to as the "light angle after". Clearly visible is the fact that the center brightness is far wider and the beam

width is greatly improved. The full angle is about 230 degree which is up from 150 degrees of usable light. The Y2 brightness angle is bumped up from about 120 degrees which up to over 180 degrees, something impossible to achieve with a conventional single row of emitters.

FIG. 36 is a light distribution pattern emitted from a conventional prior art flat plane of forward facing emitters with four light bars spaced six inches apart in one or four rows and is sometime referred to as the "light array before". FIG. 36 is a light distribution pattern emitted from a conventional prior art flat plane of forward facing emitters with the four light bars spaced six inches apart in one or four rows and is sometime referred to as the "light array before". Rows of forward-facing only emitters make almost a circular pattern of light with dramatic fall off outside of that 'hot spot' area. A better solution can be attained by putting multiple copies of the rows on each column, angled away from each other in an angle optimized per use. Such as with the light bounced back off a reflector or directly to the subject being lit. Here is an example of a cross-section of the light using two rows of emitters angled away from each other at an angle optimized to combine the two into one smooth continuous beam as if it were one row of wider-angle emitters.

FIG. 37 is a light distribution pattern emitted from four light bars of two sided delta non-curvilinear LED luminaries and is sometime referred to as the "light array before". An array of delta LED light bars will have a light distribution similar to FIG. 37. This is a far wider light distribution indicating that the light pattern will be smoother with less dark and bright zones. This same concept applies when going around the tube. The perfect light pattern can be achieved with a five sided hexagonal or a heptagonal extrusion but shown here are the difference of using a two sided and three sided LED light bar.

FIG. 38 is a light distribution pattern emitted from a conventional prior art setup using two planar row of emitters back-to-back at 180 degrees such as for illuminating a two sided outdoor sign. FIG. 39 is a light distribution pattern emitted from three sided delta or triangular non-curvilinear LED luminaries and is optimized to reduce the dim zone on the forward facing sided as well as create a balance between two dark zones that are mostly going into a reflector and the one zone that is used for direct illumination. With only three rows, a perfectly even light distribution is not physically possible, but by adjusting the angles, we can improve the forward-facing light. Though there is a slight dimming zone directly up from the center, the light distribution pattern is improved over the two dim zones that are 'south east' and 'south west' from the center. The improved LED light bar can be installed in such a way to eliminate any artifacts from those dim zones. When using a four sided tube LED light bar, the light pattern becomes nearly uniform. When using a five sided tube LED light bar, the light pattern essentially attains a 360 degree uniform light distribution.

FIG. 40 is a light distribution pattern emitted from a single emitter. FIG. 41 is a light distribution pattern emitted from a set or row of emitter of FIG. 40. FIG. 42 is a light distribution pattern emitted from a single forward facing emitter. FIG. 43 is a light distribution pattern emitted from a set or row of forward facing emitters of FIG. 4.

FIG. 44 is a graph of operational and capital costs of non-curvilinear LED luminaries in comparison with conventional LED and fluorescent luminaries where the X axis is time expressed in years and the Y axis is U.S. dollars (USD). The capital cost to replace a lighting bar (LED light bar) comprising a delta or triangular shaped LED luminary

480 which extends 48 inches is illustrated in the graph and has the lowest cost. The capital cost to replace a 48 inch fluorescent bulb **482** operating at 65 watts has a higher cost. The operational cost of a high efficiency delta or triangular shaped LED luminary **484** which is 48 inches long and emits and emits 3000 lumens (L) is shown in the graph and has the lowest operational cost. The operational cost of a high output delta or triangular shaped LED luminary **486** which is 48 inches long and emits a brighter light with an illumination of 3600 L, but with the more power and the same number of emitters as LED luminary **484**, is slightly more than the high efficiency LED luminary. A typical prior art LED luminary **486** is shown in the graph and has higher operational costs than the delta triangular shaped LED luminaries **484** and **486**. The operational costs of an existing 48 inch 65 watt (W) fluorescent tube **488** than including ballast is much more expensive than the delta triangular shaped LED luminaries **484** and **486**. The operational costs of electricity to operate a newly installed fluorescent tube **490** are the most expensive cost on the graph.

When referring to relative brightness to power, the correct term is efficacy or illuminating efficacy and it can be expressed in lumen per watt. Electrical efficiency when referring to the light bar or its components can be expressed in watts of power going into the system versus how many are delivered to the emitters themselves. Lifespan can be expressed in thousands of hours. Typically, a fluorescent tube will last 8 to 10,000 hours. A conventional LED can last about the same when driven hard as they are when used as fluorescent replacements. A high-quality SMD high-power LED will last about 50,000 hours when driven to spec and over 70,000 hours when under-driven. The models of lighting described by this patent application can be optimized to be nearly 100% efficient from the light bars themselves, that is to say, 100% of the watts going to the light-bar are delivered to the emitters. This is because the wiring goes directly to the emitters and there is not a lot of power loss on the traces. There is a tremendous gain in overall system efficiency when the emitter count is optimized to the input voltage so an extremely high-efficiency electrical driver can be utilized. Four to five time improvements in conventional efficiency can be achieved with the inventive LED light bars.

FIG. **45** is a schematic diagram of a prototype non-curvilinear LED luminary. FIG. **46** is a top view of the prototype non-curvilinear LED luminary.

FIG. **47** is a schematic diagram of another prototype non-curvilinear LED luminary. FIG. **48** is an enlarged cross-sectional view of a prototype delta three sided non-curvilinear LED luminary taken along line A-A of FIG. **47**. FIG. **49** is a bottom view of the non-curvilinear LED taken along line B of FIG. **48**.

FIG. **50** is an enlarged cross-sectional view of a further prototype delta three sided non-curvilinear LED luminary. FIG. **51** is a perspective view of part of the prototype delta three sided non-curvilinear LED luminary of FIG. **50**.

FIG. **52** is a perspective view of pin arrangements in lamp bases for compact lamp shapes. FIG. **53** illustrates the front and bottom views of pin arrangements in compact lamp bases for two pin lamps. FIG. **54** illustrates the front and bottom views of pin arrangements in compact lamp bases for four pin lamps.

In describing the preferred embodiments of the invention, which are illustrated in the drawings, specific terminology has been resorted to for the sake of clarity. However, it is not intended that the invention be limited to the specific terms so selected and it is to be understood that each specific term includes all technical equivalents that operate in a similar

manner to accomplish a similar purpose. For example, the word "connected," "attached," or terms similar thereto are often used. They are not limited to direct connection but include connection through other elements where such connection is recognized as being equivalent by those skilled in the art.

The present invention and the various features and advantageous details thereof are explained more fully with reference to the non-limiting embodiments described in the detailed description of the invention. The present invention can relate to aspects of providing electrical housings, device frame work, and a lightweight luminary body for a luminary whose illumination is provided by light emitting diodes (LEDs). The present invention can also address issues related to thermal management, heat sink, and power source integration. The more compact LED orientation can be achievable with improved management of the thermal operating loads.

FIG. **47** illustrates an existing lighting fixture **510** that is retrofitted for light emitting diode (LED) lamination. Driver **502** is provided for LED electric power. A shaft **503** is connected to a LED power strip **504**. A LED bulb **505** is connected to the LED power strip, electric power lines **506** are connected to and power the LED power strip.

FIGS. **45-51** show a light emitting diode (LED) luminary **510** according to one embodiment of the present invention. Luminary **510** includes a socket **512** that is preferably constructed to removably cooperate with a base **514**. Regardless of the specific construction of the base **514**, the base is commonly understood as that portion of a fixture that receives a luminary and provides the electrical connection between the luminary and the fixture. In one embodiment, the socket and base are constructed to cooperate in a threading manner common to many different types of luminaries. Alternatively, the socket and base can be constructed in any number of corresponding mating configurations. A number of such mating configurations are shown in FIGS. **52-54**. It is appreciated that such interactions may be provided in a number of configurations that may or may not have a threading and/or a twisting interaction between the socket and base.

Referring back to FIGS. **45** and **46**, an optional post **516** extends between the socket and a base or support **518**. The support includes one, and preferably a number of individual light emitting diodes (LEDs) **520** that can be supported in an offset orientation from the socket. Preferably, the support can be configured to isolate the LEDs from the atmosphere. It is also appreciated that the support can form a lens or the outermost translucent structure of the luminary and/or be positioned very near thereto for those instances that include a supplemental lens near support **518**.

A number of conductors or electrical connectors **522** and **524** can communicate electrical power, which are indicated by exemplary power supply **526** and/or switch **527** to the socket. The conductors **522** and **524** can extend through the optional post **516** to the support. The support **518** can be provided with a number of wire traces that are distributed about the support and electrically connect to each LED to the power source **526**. As explained further below, it is appreciated that one or more power modifying devices such as converters or drivers may be disposed between LEDs and power source. The LEDs **520** can be oriented on each of the opposite sides **528** and **530** of the generally planar shape of support **518** of the luminary.

As shown in FIG. **47**, a shroud or reflector **530** can be oriented about the luminary **510** and configured to redirect light emitted from LEDs oriented on the upward directed

side **530** of the support in a generally downward direction, indicated by arrow **534** (FIG. **48**), to improve the illumination performance of luminary. The LEDs are preferably uniformly distributed about the support.

Referring to FIGS. **47-49**, an alternate configuration of the luminary includes a generally planar multi-sided hollow support post **544** that extends in a longitudinal direction between the socket **512** and support **518**. As shown in FIG. **48**, in one embodiment of the present invention, the support post includes three walls **546**, **548**, and **550** that form a generally equilateral triangle. Although shown as having a triangular shape, it is appreciated that the support post can be provided in other generally rectilinear or substantially non-curved cross-sectional shapes. As described further below, such a configuration increases the area available for LED support and provides a beneficial configuration for the integration of power, heat dissipating, and operational control devices such as device drivers within the footprint of the luminary rather than requiring extraneous structures for housing such components. As shown in FIG. **48**, a cavity **552** enclosed by the post **544** may be sized to accommodate electrical components, such as a driver, a heat sink, a circuit board, electrical and/or thermal components **556**, associated with the powered operation of the LEDs.

FIGS. **50** and **51** show a luminary **560** according to another embodiment of the invention. The luminary can include an elongated body **562** that can comprise a number of sides **564**, **566** and **568** that can also be oriented in a rectilinear or non-curved orientation. Unlike luminary **510**, luminary **560** includes a socket **570** that is generally oriented at one end of luminary. A number of individual LEDs **572** can be distributed about at least one, and preferably more than one or each of sides **564**, **566** and **568** of the luminary. A space **573** bounded by sides **564**, **566** and **568** and socket **570** can accommodate the electronic and/or thermal equipment such as a power supply and/or electronic drivers, heat sinks and/or other thermal control structures, and/or controllers associated with the operation of LEDs. As shown in FIG. **51**, in another embodiment, a number of LEDs **572** is supported by each side **564**, **566** and **568** of the luminary **560**. Such an orientation can increase the range of lumen output associated with luminary **560** as compared to conventional prior art luminaries having similar spatial requirements. Although the LEDs **572** are shown as being supported on a lens forming structure of luminary **560**, it is appreciated that the LEDs could be supported on an internal power strip or circuit board having a generally similar shape as the luminary and can be oriented in close proximity to the interior surface of sides **564**, **566** and **568**. Such an LED support can be longitudinally translatable relative to the exterior surface of the luminary during the assembly thereof. The LEDs can be integrated into each of sides **564**, **566** and **568** such that each of the respective sides of the luminary forms the lens and isolates the LEDs from the atmosphere.

The shape of the frame work, housing configuration, and considerations of thermal management can allow the placement of LEDs on a broader surface area than known conventional luminaries. This dispersed placement of the LEDs can allow greater degree of light dissipation and greater lumen output. In one preferred embodiment, the non-circular or rectilinear orientation of the LEDs can allow up to three surface points for placement of the individual light sources. The preferred embodiment can include a frame work housing and thermal management channel that also allows for selective internal or external placement of a power source that powers the light source. Regardless of the proximate orientation of the power source, the luminary can

allow greater thermal management for heat dissipation. In a preferred embodiment, the luminary has a three-sided, triangular or delta cross-sectional shape. It is appreciated that the lumen can have any number of generally non-curved shapes including a square or virtually any number of planar side members. When provided in a delta or triangular shape, it is appreciated that the lumen can be provided in virtually any shape including equilateral and/or isosceles triangular shapes. The multiple planar surface structures allows for greater variation in the lumen orientation and position and a broader lumen mounting area to provide greater light.

It is envisioned that the socket of the lumen (luminary) can be configured to cooperate with virtually any base receptacle including, but not limited to, those shown in FIGS. **52-54**. Such bases can also include other bases. It is envisioned that the luminary of the present invention can be provided in a shape applicable to any base configuration. The luminary can be configured to operate in the range of about 1 watt to about 1000 watts or more power usage. The luminary can provide a full spectrum of kelvin colors and can be configured for operation at all voltages including the most common voltages of 12 volts (v), 24 v, 110 v, 120 v, 208 v, 277 v, and 480 v. It is further appreciated that the luminary can be provided in virtually any length including lengths ranging from about 2 inches to about 96 inches or more and lengths common to the lighting industry.

The disclosed luminary can provide for greater surface area for LED light source than any known conventional luminary having a comparable footprint. The luminary construction can also allow for internal or external placement of a power supply source while allowing thermal management and greater lumen output and greater degree of light spread. The luminary can be configured to be a suitable plug and play configuration to provide enhanced LED lighting that suitable for operation with conventional fluorescent type lighting.

This invention can allow more surface area for placement of LEDs for the purpose of increased lumen output and greater degree of light dispersion. This can allow provisions for an internal or an external power supply, source, controllers, connections, and/or thermal control devices. The triangular shape can allow up to three points for light surface and thermal management to provide a luminary with a greater operating range and improved power management.

The improved light emitting diode (LED) illuminating assembly can comprise a multiple sided modular LED lighting bar, which is also referred to as a multi-sided LED light bar, comprising a non-curved (LED) luminary with a multi-sided elongated tubular array having multiple, several, numerous or many sides comprising modular boards which can define panels with longitudinally opposite ends. The tubular array preferably can have a non-curved cross-sectional configuration (cross-section) without and in the absence of a circular cross-sectional configuration, oval cross-sectional configuration, elliptical cross-sectional configuration and a substantially or rounded curved cross-sectional configuration. Each of the sides of the multi-sided tubular array can have a generally planar flat surface as viewed from the ends of the array, and adjacent sides which intersect each other and converge at an angle of inclination. Operatively positioned and connected to the multi-sided array can be an internal non-switching printed circuit board (PCB) driver comprising a driver board. The driver can be an interior or inner driver board positioned within an interior of the tubular array or can be an exterior or outer driver board which comprises and provides one of the sides of the tubular array. Desirably, two or some of the sides comprise

31

modular LED emitter boards which can provide elongated LED PCB panels. The internal driver comprising the driver board can drive the LED emitter boards and can comprise one or more modular driver boards that are connected in series and/or parallel with each other.

The improved LED illuminating assembly comprising a multi-sided light bar providing a non-curvilinear (LED) luminary can have an optimal count of LED emitters comprising a group, set, matrix, series, multitude, plurality or array of light emitting diodes (LEDs) securely positioned, mounted and arranged on each of the emitter boards for emitting and distributing light outwardly from the emitter boards in a light distribution pattern for enhanced LED illumination and operational efficiency.

End cap PCB connectors providing connector end boards which are also referred to as end cap boards can be positioned at the ends of the tubular array and connected to the internal driver board and the emitter boards. The connector end boards can have power connector pins which can extend longitudinally outwardly for engaging and providing an electrical power connection with at least one light socket. End caps can be positioned about the end cap PCB connectors. The end caps can have bracket segments which can provide clamps that can extend longitudinally inwardly for abuttingly engaging, grasping and clamping the emitter boards.

The boards comprising the emitter boards and driver board can be generally rectangular and modular. Each of the sides of the multi-sided array comprising emitter boards can comprise a single emitter board or a set, series, plurality, multitude or multiple elongated emitter boards longitudinally connected end to end. The sides comprising the emitter boards can include all of the sides of the tubular array or all but one of the sides of the tubular array with the one other side comprising the driver board. The driver board can comprise a single driver board or multiple driver boards that are longitudinally connected end to end. The boards can have matingly engageable male and female connectors such that the connectors on the connector end boards matingly engage, connect and plug into matingly engageable female and male connectors on the driver board and/or on the emitter boards.

A multiple sided tubular heat sink comprising multiple metal sides can be positioned radially inwardly of the multi-sided tubular array for supporting and dissipating heat generated from the emitter boards and driver board(s). The heat sink can have a tubular cross-section which can be generally complementary or similar to the cross-sectional configuration of the multi-sided tubular array. The cross-section of the heat sink preferably has a non-curvilinear cross-section without and in the absence of a circular cross-section, oval cross-section, elliptical cross-section and a substantially curved or rounded cross-section.

The improved LED illuminating assembly comprising a multi-sided light bar providing a non-curvilinear (LED) luminary can have emitter traces for connecting the LED emitters in parallel and in series and can have alternating current (AC) and/or direct current (DC) lines. The emitters can comprise at least one row of substantially aligned aliquot uniformly spaced LED emitters. Desirably, the multi-sided light bar provides a no wire design in the absence of electrical wires.

The improved LED illuminating assembly comprising a multi-sided light bar providing a non-curvilinear (LED) luminary can also have a diffuser comprising an elongated light diffuser cover which can provide a light transmissive

32

lens that can be positioned about and cover the LED emitters for reflecting, diffusing and/or focusing light emitted from the LED emitters.

In one embodiment, the lighting bar comprises: a two sided modular LED lighting bar; the array comprises a two sided array; the heat sink comprises a heat sink with at least two sides; and the emitter boards are arranged in a generally V-shaped configuration at an angle of inclination ranging from less than 180 degrees to an angle more than zero degrees; and the driver is positioned in proximity to an open end of the V-shaped configuration.

In another embodiment, the lighting bar comprises: a three sided modular LED lighting bar; the array comprises a three sided delta or triangular array; the heat sink comprises a tubular three sided heat sink with a delta or triangular cross-section; and the angle of inclination can range from less than 180 degrees to an angle more than zero degrees, and is preferably 120 degrees. The driver can be positioned within the interior of the delta or triangular cross-section of the three sided heat sink.

In a further embodiment, the lighting bar comprises: a four sided modular LED lighting bar; the array comprises a square or rectangular array; the heat sink comprises a tubular four sided heat sink with a square or rectangular cross-section; and the angle of inclination can be a right angle of about 90 degrees.

In still another embodiment, the lighting bar comprises: a five sided modular LED lighting bar; the array comprises a pentagon array; the heat sink comprises a tubular five sided heat sink with a pentagon cross-section; and the angle of inclination of the intersecting sides of the pentagon can comprise an acute angle such as at about 72 degrees.

Multi-sided LED light bars, arrays and heat sinks with more than five sides can also be used.

The improved LED illuminating assembly can comprise an illuminated LED sign, such as an outdoor sign or an indoor sign. The outdoor sign can comprise an outdoor menu board, such as for use in a drive through restaurant. The indoor sign can comprise an indoor menu board such as for use in an indoor restaurant. LED signs can also be provided for displays and other uses. The illuminated LED sign can comprise: a housing with light sockets; at least one light transmissive panel providing an illuminated window connected to the housing; multiple sided modular LED lighting bars, which are also referred to as multi-sided light bars, of the type previously described, can be connected to the light sockets for emitting light through the illuminated window; and the illuminated window can be moved from a closed position to an open position for access to the LED lighting bars. The lighting bars can extend vertically, horizontally, longitudinally, transversely or laterally along portions of the housing. The illuminated window can be covered by a diffuser.

The improved LED illuminating assembly can also comprise: an overhead LED lighting assembly providing overhead ceiling light with: translucent ceiling panels comprising light transmissive ceiling tiles; at least one drop ceiling light fixture comprising light sockets; and at least one multiple sided modular LED lighting bar (multi-sided light bar) of the type previously described, connected to the light sockets and positioned above the ceiling panels for emitting light through the translucent ceiling panels in a general downwardly direction and diverging toward a floor or room. One or more concave light reflector can be positioned above the LED lighting bar to reflect light downwardly through the translucent ceiling panel into the room.

Among the many advantages of the light emitting diode (LED) illuminating assemblies provided with a multi-sided LED light bar comprising a non-curved LED luminaire are:

1. Superior product.
2. Outstanding performance.
3. Superb illumination.
4. Improved LED lighting.
5. Excellent resistance to breakage and impact.
6. Long useful life span.
7. User friendly.
8. Reliable.
9. Readily transportable.
10. Lightweight.
11. Portable.
12. Convenient.
13. Easy to use and install.
14. Less time needed to replace the light bar.
15. Durable
16. Economical.
17. Attractive.
18. Safe.
19. Efficient.
20. Effective.

There are many other advantages of the inventive LED illuminating assembly with a novel multi-sided LED lighting bar comprising a non-curved LED luminaire versus conventional LED lighting.

1. The use of multi-sided light bar allows for a much wider distribution of light. A standard solution has about 100-110 degree light beam to half brightness. The inventive LED illuminating assembly with the novel multi-sided LED lighting bar, however, can reach a full 360 degrees with little or no loss of brightness. Furthermore, the illustrated two-sided design can reach over 180 degrees to half-brightness. Another advantage is near-field use; lighting something just a few inches from the light source.

2. The internal driver of the improved LED illuminating assembly with the multi-sided lighting bar is less expensive, uses less labor, is simpler and has lower chance of failure over conventional lighting.

3. The non-switching driver of the improved LED illuminating assembly with the multi-sided lighting bar provides a boost of efficiency on the scale of 47 magnitude. A typical switching driver which is used on conventional LED lighting bars has a typical efficiency of 80-85% or 15-20% loss. In contrast, the improved LED illuminating assembly with the multi-sided lighting bar can have an efficiency of 95-97% (3-5% loss), and is four to seven time more efficient than conventional lighting and this improved results in about 20% overall efficiency gain. Desirably, the improved LED illuminating assembly with the multi-sided lighting bar can achieve greater than 90% efficiency, which is practically impossible with conventional switching drivers.

The improved LED illuminating assembly with the multi-sided lighting bar desirably can optimize the emitter count to the voltage source and can advantageously utilize wiring of the emitters in the appropriate numbers in a parallel-series arrangement.

In the improved LED illuminating assembly with the novel multi-sided lighting bar, the diffuser comprising the lens can be modified to change the output of the beam. By use of this arrangement, dark spots can be eliminated so that a much higher illuminating output can be attained. The improved LED illuminating assembly with the multi-sided lighting bar example can emit a 360 degree beam without visible hot or cold spots. The improved LED illuminating

assembly with the multi-sided lighting bar can also have scalable length since there is no theoretical limit to the length of the novel arrangement and design. The actual length may be limited, however, by customer needs, costs, available space, and production capabilities.

The improved LED illuminating assembly with the multi-sided lighting bar further can have driver redundancy using parallel and multiple driver sub-circuits for even better reliability. This can achieve two other important goals:

1. The improved LED illuminating assembly with the multi-sided lighting bar can attain even, uniform accurate power levels to all emitters. In contrast, conventional LED designs do not control the current to all the emitters evenly, but apply a metered amount of current to all parallel circuits, typically as many as three to eight of them, and the current can vary on each parallel circuit because there is no control per sub-circuit. The improved LED illuminating assembly with the multi-sided lighting bar can control each sub-circuit independently so that every emitter in the entire light assembly gets exactly the same current.

2. The improved LED illuminating assembly with the multi-sided lighting bar achieves reliability of output during normal operating conditions and in the event of sub-circuit failure.

In a conventional LED design with output 300 mA to three branches or sub-circuits, when one branch fails, then two sub-circuits will share that same 300 mA so they will go from 100 mA to 150 mA, which is a huge change in current that is not desirable and is likely to cause a cascading failure. In the improved LED illuminating assembly with the multi-sided lighting bar, if one sub-circuit fails, the remaining circuits operate exactly as they were before the failure.

Furthermore, in the improved LED illuminating assembly with the multi-sided lighting bar, the sub-circuits can be spread out so that no one portion of the light assembly goes completely dark, but will just dim. This can be very important when lighting up a sign so that although it may be a little darker in one spot, the sign will still illuminate brightly and be readable.

In conventional LED illumination, all the emitters are typically in series with each other so in the event of a single LED failure that entire row blinks out and that entire portion of the light assembly will go dark. In the improved LED illuminating assembly with the multi-sided lighting bar, the strings or set of emitters are aligned and connected in parallel with the other emitter so that in the event of failure of one sub-circuit, the LED lamp of the LED illuminating assembly goes to 50% brightness but is evenly lit from edge to edge.

The improved LED illuminating assembly with the multi-sided lighting bar also achieves efficiency over initial capital costs. Conventional LED designs attempt to maximize lumens per emitter and are designed according to the specification ("spec") of the emitter. Emitters operating 'at spec' tend to net about 80 Lumen/watt total.

The improved LED illuminating assembly with the multi-sided lighting bar can be specifically under-driven to achieve some very valuable goals:

1. Longer life span. For example, an emitter run at 70% of rated capacity will last 70-80,000 hours when specified at 50,000 hours. That's a difference of 8.6 to 5.7 years when operating at 24 hours per day at seven days a week.

2. Higher efficacy. The improved LED illuminating assembly with the multi-sided lighting bar can achieve over 100 L/W system total by de-tuning the current drive of the emitter. The improved LED illuminating assembly with the multi-sided lighting bar can achieve the same total output by

adding more emitters. The initial cost maybe higher but the operational cost will be much lower. This is shown in the illustrated operational costs chart which compares the high output 3600 L LED light bar to the high efficiency 3000 L LED light bar with the exact same design but at different drive operating levels because the LEDs are more efficient and last longer when driven below spec.

3. Higher reliability. Within their expected lifespan, LED emitters will maintain lumen longer and maintain color temperature longer when they are cooler, if the temperature is directly proportional to LED drive current. An over-driven LED will lose color temperature accuracy quicker than one driven at spec. An under driven LED can maintain lumen and color temperature longer than even one driven to 'spec'.

The improved LED illuminating assembly can have a no-wire design such that the novel light bar of the improved LED luminary assembly has no electrical wires. This arrangement can decrease assembly time and problems and lower failure rate associated with complexity in a manual labor portion of the assembly. A conventional LED light bar can have 12 or more hand-made solder joints. The new inventive light bar design can include only two hand-made solder joints as well as eliminating 100% of the electrical wiring. Elimination of standard electrical wires can increase both initial and long term reliability and expenses.

The embodiments described above use a driver board including circuitry which converts AC to DC for driving the LEDs that use a DC supply of the correct electrical polarity. The driver board adds to the overall component cost, assembly cost and design cost of tubular LED lighting assemblies and requires additional space in the assembly. Power loss in the range of 15% or higher typically result from the conversion from AC to DC. The driver components, such as rectifiers to convert AC into pulsed DC and filters to smooth the signal to a constant DC voltage, have high failure rates compared to other longer lasting components of tubular LED lighting assemblies. The use of highly reliable components is important, but can add substantial cost and may entail complex designs.

LED-based solid state lighting provides the opportunity for significant reduction in the carbon footprint of the electrical power grid due to the dramatic reduction in real power consumption. However, if power factor is not managed, the grid will still need to be able to provide a much higher power level than is actually needed at the load, eliminating a significant portion of the benefits of moving to solid state lighting. Power factor is a unit-less ratio of real power to apparent power. Real power is the power used at the load measured in kilowatts (kW). Apparent power is a measurement of power in volt-amps (VA) that the grid supplies to a system load. In a highly reactive system, the current and voltage, both angular quantities, can be highly out of phase with each other. This results in the power grid needing to supply a much larger reactive power to be able to supply the actual real power at any given time. Incandescent bulbs have historically had a very high power factor. LEDs have a non-linear impedance as do their drivers, causing the power factor to be inherently low. In order to combat this, the drivers typically include power factor correction circuitry to increase that ratio to as close to 1 as possible. However, as mentioned above, significant power is still typically lost in converting AC to DC current, resulting in less than ideal power factor ratios.

The LEDs, being diodes, conduct current in only a single direction. However, AC driven LEDs are also available as an alternative to DC solutions. AC LEDs do not require an AC to DC driver circuit. With AC LED technology an LED is

directly connected to AC power, or through a limiting resistor circuit. A rectifier diode may be used to prevent reverse bias. With AC as a driving source, the LED will only illuminate about fifty percent of the time. However, the noticeable effect of this can be minimized through circuitry design. For general illumination, AC LED technology can sometimes allow simpler form factors to enhance manufacturing or aesthetics and have the benefit of eliminating the converter and driver components. AC LEDs also allow the lamp to dim and to shift the spectrum of the lamp as it dims to mimic an incandescent light or other colors. Lighting using AC LEDs can also achieve a higher power factor because the power loss associated with DC LED driver circuits is avoided.

AC LED technology has been deployed in some lighting applications, such as street lighting and conventional screw in type bulbs. Despite the potential advantages of AC LED technology, tubular LED lighting assemblies have traditionally deployed only DC LEDs, and the applicant is not aware of any such tubular LED lighting assemblies using AC LEDs. One challenge associated with tubular lighting applications is that the intensity and consistency of the light distribution pattern is particularly important. Conventional LED tubular lamps, utilizing one or more LED emitter panels oriented in the same plane within a cylindrical tubular diffuser lens, are typically operated at a high percentage of the LED power rating and rely on the resulting intensity and overspill of light towards the sides to improve the light distribution pattern. AC LEDs operate at a lower efficiency when driven at higher power levels, and this presents an obstacle to a high-efficiency tubular lamp of optimal light intensity and distribution performance.

The present invention, however, can readily be adapted to provide tubular lighting forms utilizing AC powered LEDs as an illumination source, thus permitting the elimination of the driver circuit and providing other advantages associated with AC LED technology. In particular, embodiments employing a multi-sided luminary formed of multiple LED emitter boards oriented in intersecting planes provide for a greater number of LEDs and direct the emitted light over a wider angle. AC LEDs can thus be deployed in these embodiments and operated at lower, more efficient power levels while still achieving substantial light intensity and consistent light distribution patterns over a wide area. As explained in more detail below, elimination of the driver circuit also enables other forms such as embodiments which utilize a single AC LED emitter panel that is positioned on a lower profile heat sink and spaced further from a curved diffuser cover to capture a wider angle of light emanating from the LEDs and disburse the light evenly and consistently.

Embodiments of the invention employing AC LED technology eliminate power loss associated with the conversion of AC to DC voltage and can achieve a higher power factor compared to DC LED designs. These embodiments of the invention can be provided as a less complex design in simpler form factors to enhance manufacturing and/or aesthetics, and are potentially more reliable and longer lasting due to a reduction in the number of components that can fail. This is significant advantage to customers who require longer life bulbs to offset the greater up front cost of solid state LED lighting compared to conventional tube lighting. These embodiments further provide for dimming control and the ability to shift the spectrum of the lamp as it dims to mimic an incandescent or other colors.

Referring to FIGS. 55-61, one conventional form of elongate tubular lighting assembly is shown at 600. The

lighting assembly 600 consists of an elongate body 602 on, or within, which an illumination source 604 is provided. The illumination source 604 is shown in schematic form to generically represent all existing illumination sources, including those utilizing LEDs, a gas-discharge lamp that uses fluorescence to produce visible light, etc.

The body 602 has first and second end connectors 606, 608, respectively at first and second lengthwise ends of the body 602. The end connectors 606, 608 respectively mechanically and electrically interconnect with connectors 610, 612 mounted on a support 614, that may define a reflector for controllably dispersing light generated by the illumination source 604 and directed thereat. The interaction of the connectors 606, 610 and 608, 612 is substantially the same and thus description herein will be limited to the interaction of the exemplary connectors 606, 610 through which one tube end is mechanically supported and the illumination source 604 is electrically connected to a power supply 616.

The connector 606 has a bi-pin/2-pin arrangement with separate power lead pins 618, 620, which have substantially the same construction and project in cantilever fashion from diametrically opposite locations relative to the body axis 622.

The connector 610 is what is conventionally referred to in the industry as a "tombstone" connector, since it generally resembles a tombstone in terms of its shape. The connector 610 has a mounting portion 624 from which a "tombstone"-shaped portion 626 depends. The mounting portion 624 is designed to slide into its operative position along rails defined by a pair of tabs 628, 630 struck from the support 614. The connectors 610 may be permanently or releasably fixed with respect to the support 614.

The depending connector portion 626 has a pair of non-conductive tabs 632, 634, that project in generally parallel, spaced relationship to define a slot 636 therebetween. The tubular lighting assembly 600 will be described herein as being in an orientation wherein the axis 622 of the body 602 is substantially horizontal. With this arrangement, the slot 636 extends in a substantially vertical line. The tabs 632, 634 project from the base of a cup-shaped receptacle 638 so that there is an annular pathway 640 surrounding the tabs 632, 634 within the receptacle 638. A bottom opening 642 is defined for introducing the pins 618, 620.

To operatively position the connector 606, the body 602 is angularly oriented so that the axes of the power leads/pins 618, 620 reside in the same vertical plane. With the body 602 in this orientation, the pins 618 can be directed, one after the other, through the opening 642, with the leading pin 618 advanced to and through the slot 636 so that the pins 618, 620 reside in diametrically opposite regions of the annular pathway 640. By then turning the body 602 around its axis through 90°, the pin 618 becomes wedged between the tab 634 and a first conductive component 644 within the receptacle 638. The pin 620 wedges in the same manner between the tab 632 and a second conductive component 646 that is generally diametrically opposite to the first conductive component 644 within the receptacle 638. Through the conductive components 644, 646, the pins 618, 620 establish electrical connection between the illumination source 604 and the power supply 616. An electrical circuit is completed by power leads/pins 618', 620' on the connector 608 that have the same bi-pin arrangement and cooperate with the connector 612 in the same manner that the pins 618, 620 cooperate with the connector 610.

Installation of the body 602 requires controlled movement between the connectors 606, 608 at the ends and the coop-

erating connectors 610, 612. If the pins 618, 620, 618', 620' are not all consistently aligned and appropriately moved, electrical connection of the illumination source 604 may not be established. Improper alignment and movement of the pins 618, 620, 618', 620' during the assembly process may also result in one or more of the pins 618, 620, 618', 620' not appropriately seating. Since the integrity of the mechanical connection of the body 602 relies on stable securing of the pins 618, 620, 618', 620', improper pin seating may allow the body 602 to be inadvertently released, which may cause it to be damaged or destroyed.

Aside from the inconvenience of installing the body 602, the body 602 may still be prone to releasing, even after proper installation. As seen in FIGS. 58 and 59, the connectors 610, 612, by reason of their overall depending construction, are prone to being deflected oppositely away from each other, as indicated by the arrows 648, 650. A slight deflection at the bottom region of the connectors 610, 612 may be adequate to release the power leads/pins 618, 620, 618', 620' from one or both of the connectors 610, 612. Such deflection might be caused by nothing more than the weight of the body 602.

Further, after repetitive force application to the connectors 610, 612, as during installation and removal of the body 602, the support 614, which is typically light gauge sheet metal, may progressively deform at the locations where the connectors 610, 612 are joined thereto.

Still further, the connectors 610, 612 may slide away from each other under typical forces applied during installation and replacement of the body 602. Those designs, which require a sliding movement of the connectors 610, 612 during assembly, are particularly prone to this problem. That is, one or both of the connectors 610, 612 might move oppositely to its installation direction adequately that the free ends of the pins 618, 620, 618', 620' are not firmly and positively supported. Significantly, there may be no positive blocking of a slight movement of the connectors 610, 612, or a deflection thereof adequate to inadvertently release the body 602 either during, or after, installation.

One preferred form of elongate tubular lighting assembly, according to the present invention, is shown at 654 in FIGS. 62-78. FIG. 78 shows the basic components of the tubular lighting assembly 654 in schematic form, to encompass the specific design as shown in FIGS. 62-77, and any of potentially limitless variations thereof which would be apparent to one skilled in the art based upon the disclosure herein.

As seen in FIG. 78, the tubular lighting assembly 654 has a body 656 with a length between first and second ends 658, 660. A source of illumination 662 is provided on or within the body 656.

The source of illumination 662 could be any structure that is provided in a generally tubular form and is capable of generating visible light. While the particular embodiment described in FIGS. 62-77 utilizes LEDs, the invention contemplates using the same principles to construct any type of lighting assembly having a generally elongate tubular body shape between spaced ends at which the body is supported in an operative state. As but one example, the source of illumination may be a gas-discharge lamp that uses fluorescence to produce visible light and conventional bi-pin/2-pin leads at its ends. Other designs are contemplated, either alone or in combination.

A first connector 664 at the first end 658 of the body 656 is made up of a first connector part 666 and a second connector part 668. A second connector 670 is provided at the second end 660 of the body 656 and is made up of a third connector part 672 and a fourth connector part 674. The first

and second connectors **664**, **670** are configured to maintain the body **656** in an operative state on a support **676** that may be in the form of a reflector, or otherwise configured. The first connector part **664** is part of a first end cap assembly **678** that is provided at the first body end **658**. The second connector part **668** is provided on the support/reflector **676**. The third connector part **672** is provided at the second end **660** of the body **656**, with the fourth connector part **674** provided on the support/reflector **676**. The source of illumination **662** is electrically connected to a power supply **680** through the first connector **664**.

Referring now to FIGS. **62-77**, details of one exemplary form of the generically depicted elongate tubular lighting assembly **654** of FIG. **78** will be described. The body **656** has the basic components of the illuminating assembly/luminary shown in FIGS. **15** and **16**, and described hereinabove. Generally, this construction consists of the three-sided delta, or triangularly-shaped, metal heat sink **297** with two LED emitter panels **293** positioned in a generally “V”-shape on the heat sink **297**. Each of the LED emitter boards/panels **293** has a plurality of LED emitters **298** spaced at generally uniform intervals along the length thereof between the ends **658**, **660** of the body **656**. The LED emitter panels **293** provide the source of light of the illumination source **662** depicted in FIG. **78**. Each of the LED emitter panels **293** has terminals **302** in the form of conductive components **682** projecting in a lengthwise direction from the opposite ends of the emitter panels **293**.

As described above, the first connector **664** is provided at the first end **658** of the body **656**, with the second connector **670** provided at the second end **660** of the body **656**. The first connector **664** consists of the first connector part **666**, that is part of the first end cap assembly **678**, and the second connector part **668**. The first end cap assembly **678** consists of a first, cup-shaped component **684** defining a first receptacle **686** opening towards the body **656** and into which the first end **658** of the body extends.

The receptacle **686** receives an end connector board **688** which overlies a separate board **690** having L-shaped electrical connector components **692** thereon that cooperate with connector components **694**, **696** within wires that extend into the second connector part **668** to establish electrical connection between the boards **688**, **690** and the power supply **680**.

In this embodiment, the first connector part **666** has three like mounting posts **698** projecting from within the receptacle **686**. The posts **698** have stepped diameters to produce shoulders **700** to bear simultaneously against one side **702** of the board **690**. The opposite side **704** thereof facially engages a surface **706** on the connector board **688** to positively support the same.

The conductive components **682** on the emitter panel terminals **302** are designed to electrically connect to conductive components **708** on the terminals **324** through a press fit operation. More specifically, the source of illumination **662** and connector boards **688**, **690** are configured to be electrically connected as an incident of the first end **658** of the body **656** and first end cap assembly **678** being moved towards each other in a direction substantially parallel to the length of the body **656**. As this occurs, the first end **658** of the body **656** extends into the receptacle **686** to thereby place the first end **658** of the body **656** and first end cap assembly **678** in mechanically and electrically connected relationship.

A single board **697**, as shown schematically in FIG. **70a**, may be used in place of, and to perform the combined functions of, the separate boards **688**, **690**. Identical, or like, connector components **692**, as seen in FIG. **72**, may be

mechanically and electrically connected to the board **697** to provide an electrical path from the connector components **694**, **696** to the board **697** on which the cap board terminals **324**, or like terminals, are provided. The cap board terminals **324** cooperate with the emitter board terminals **302**, as described above.

As seen in FIG. **78**, the first connector part **666** has a first surface **710** with the second connector part **668** having a cooperating second surface **712**. The first and second connector parts **666**, **668** are configured so that the first and second surfaces **710**, **712** are placed in confronting relationship to prevent separation of the first and second connector parts **666**, **668** with the body **656** in its operative state. This relationship is affected as an incident of the first connector part **666** moving relative to the second connector part **668**, initially from a position fully separated from the second connector part **668**, in a path that is transverse to the length of the body **656**, into an engaged position. The generic showing of the structure in FIG. **78** is intended to encompass a wide range of different structures that can achieve the same structural objective in joining the connector parts **666**, **668**. It is contemplated by the generic showing that the first and second connector parts **666**, **668** are configured so that the first connector part **666** moves against the second connector part **668** as the first connector part moves towards the engaged position, thereby causing a part of at least one of the first and second connector parts **666**, **668** to reconfigure to allow the first and second surfaces **710**, **712** to be placed in confronting relationship.

The detailed description hereinbelow will be focused on the exemplary embodiment shown in FIGS. **62-77**. As noted, this embodiment is only one exemplary form of the many different forms contemplated for the various components shown schematically in FIG. **78**, including the configuration of the first and second connector parts **666**, **668**.

In FIG. **74**, the first connector part **666** is shown in a position fully separated from the second connector part **668**. In FIG. **75**, the first connector part **666** is shown moved relative to the second connector part **668** from the fully separated position in a substantially straight path, as indicated by the arrow **714**, transverse to the length of the body **656**, into the engaged position.

To make this interaction possible, the first connector part **666** has an opening **716** bounded by an edge **718**. The second connector part **668** has a first bendable part **720**. The second connector part **668** is configured so that the first bendable part **720** is engaged by the edge **718** of the opening **716** and progressively cammed from a holding position, as shown in solid lines in FIGS. **74** and **75**, towards an assembly position, as shown in dotted lines in each of FIG. **74** and FIG. **75**, as the first connector part **666** is moved up to and into the engaged position. The first bendable part **720** moves from the assembly position back towards the holding position with the first part realizing the engaged position.

In this embodiment, the first connector part **666** has a wall **722** through which the opening **716** is formed. The first surface **710** is a portion of the inner surface of this wall **722**. The second surface **712** is defined by a boss **724** on the bendable part **720**.

The wall **722** has a third surface **726** on its opposite surface that faces towards a fourth surface **728** on the second connector part **668**. The wall **722** resides captively between the second and fourth surfaces **712**, **728** with the first connector part **666** in the engaged position to maintain this snap-fit connection.

In this embodiment, the first bendable part **720** is joined to another part **730** of the first connector part **666** through a

live hinge 732. The second connector part 668 has an actuator 734, in this embodiment on the first bendable part 720 remote from the hinge 732, that is engageable and can be pressed in the direction of the arrow 736 in FIG. 74 with the first connector part 666 in the engaged position, thereby to move the first bendable part 720 towards its assembly position, as shown in dotted lines in FIGS. 74 and 75, to allow the surface 712 to pass through the opening 716 so that first connector part 666 can be separated from the second connector part 668.

In the depicted embodiment, the second connector part 668 has a second bendable part 720' that is configured the same as the first bendable part 720 and cooperates with the edge 718 in the same way that the first bendable part 720 cooperates with the edge 718 in moving between corresponding holding and assembly positions. An actuator 734' is situated so that the installer can grip and squeeze the actuators 734, 734', as between two fingers, towards each other, thereby changing both bendable parts 720, 720' from their holding positions into their assembly positions.

As seen in FIG. 76, the edge 718 extends fully around the opening 716. Preferably the opening 716 and second connector part 668 are configured so that the edge 718 and a peripheral surface 738 on the second connector part, that is advanced therethrough, cooperate to consistently align the second connector part 668 with the opening 716 as the second connector part 668 is directed into the opening 718 as the first connector part 666 is changed between the fully separated position and the engaged position. Matching, non-round shapes achieve this objective.

Also, this arrangement keys the connector parts 666, 668 together as a unit so that they do not move any substantial distance along the length of the body 656. As seen in FIG. 76, a portion 740 of the peripheral surface 738 bears on a portion 742 of the edge 718 to prevent lengthwise movement of the connector part 666 in the direction of the arrow 743, as might permit separation of the first connector part 666 from the first end 658 of the body 656.

The third and fourth connector parts 672, 674, that make up the second connector 670, may be respectively structurally the same or similar as the first and second connector parts 666, 668 and interact with each other at the second end 660 of the body 656 in the same way that the first and second connector parts 666, 668 interact with each other at the first end 658 of the body 656. Accordingly, the first and third connector parts 666, 672 are held positively captively against their respective body ends 658, 660 by the second and fourth connector parts 672, 674, thereby avoiding inadvertent separation of the connector parts 666, 672 from the body ends 658, 660, respectively.

The second connector part 668 has oppositely opening slots 744, 746 that cooperate with the reflector tabs 628, 630 in the same manner that the connectors 626 (see FIG. 56) do. That is, the tabs 628, 630 are formed so that they can slide through the slots 744, 746 whereby the second connector part 668 and support/reflector 676 can be press connected starting with these parts fully separated from each other. A simple sliding movement lengthwise of the body 656 will fully seat the tabs 628, 630 that become frictionally held in the slots 744, 746. Of course other, and potentially permanent, connections are contemplated.

With the above described arrangement, the first and second connector parts 666, 668 can be mechanically snap-connected through a simple movement of the first connector part 666 from its fully separated position into its engaged position. The connector components 692, 694, 696 are also configured so that the connector components 694, 696 are

press fit into electrical connection with the connector components 692 as an incident of the first connector part 666 moving from its fully separated position into its engaged position.

The third connector part 672 is part of a second end cap assembly 748 at the second end 660 of the body 656. The second end cap assembly 748 has a second cup-shaped component 750 defining a receptacle 752 that receives the second body end 660 in substantially the same manner as the first cup-shaped component 684 receives the first end 658 of the body 656. The oppositely opening cup-shaped components 684, 750 captively engage the body ends 658, 660 which reside in their respective receptacles 686, 752. The receptacles 686, 752 are deep enough that the body ends 658, 660 penetrate an adequate distance to be securely held within the receptacles 686, 752.

In this embodiment, the second end cap assembly 748 includes at least one, and in this case two, connector boards 688', 690', corresponding to the boards 688, 690, described above.

The source of illumination 662 and connector boards 688', 690' are configured to be electrically connected as an incident of the second end 660 of the body 656 and second end cap assembly 748 being moved towards each other in a direction substantially parallel to the length of the body 656 into connected relationship.

The light diffuser cover 328, previously described, is optionally used to deflect, diffuse, and/or focus light from the source of illumination 662.

With the above-described construction, the first and second connector parts 666, 668 are configured to be structurally held together, independently of the conductive connector components 692 and 694, 696 that electrically connect between the source of illumination 662 and power supply 680, to thereby maintain the body 656 in its operative state. This avoids stressing of conductive components that effect electrical connection on the lighting assembly 654 and also permits rigid and maintainable mounting of the body 656 in its operative state. This ability becomes particularly significant with long body constructions, typically up to eight feet, with an LED source of illumination. These bodies may have a significantly heavier construction than their fluorescent bulb counterparts.

With the above-described construction, the first and second connector parts 666, 668 and third and fourth connector parts 672, 674 can be simply aligned and snap-connected to each other to thereby be held together as an incident of relatively moving the connector parts towards and against each other. Supplemental fasteners (not shown) could be used for further securing these connections, but ideally no supplemental fasteners are required.

The above-described construction lends itself to pre-assembling the first and third connector parts 666, 672 to their respective body end 658, 660 by a simple press fit step. The resulting unit U (FIG. 67) can then be situated to align the first and third connector parts 666, 672 with the second and fourth connector parts 668, 674, whereupon a translational movement of the unit snap-connects the first and second connector parts 666, 668 and third and fourth connector parts 672, 674. The snap connection of the connector parts 666, 668 and 672, 674 also effects electrical connection between conductive connector components associated therewith.

The use of the boards 688, 688', 690, 690' and press connection of the end cap assemblies 678, 748 potentially avoids certain, and in a preferred form all, wire connecting operations, that may be labor intensive, difficult to perform,

and often lead to operational failures. That is, as seen at one exemplary body end 658, the electrical connection of the emitter boards 293 can be effected through cooperation between the terminals 302, 324 and connector board 688 up to the connector components 692 without the use of any wire that would have to be soldered or otherwise connected at its ends.

Further, the body ends 658, 660 can project adequately into their respective receptacles 686, 752 that there is little risk of separation of the body 656 from its operative state.

The second and fourth connector parts 668, 674 can be configured to replace conventional fluorescent bi-pin bulb connectors, as shown at 610 and 612 in FIGS. 56 and 57. The conventional connectors 610, 612 lend themselves to being readily removed and replaced by the connector parts 668, 674 potentially without any, or any significant, modification to the support 614. Thus, retrofitting of LED-based technology is facilitated.

Once the connector parts 668, 674 are in place, either through initial assembly or as replacements for the connectors 610, 612, the body 656 and pre-joined connector parts 666, 672, that cooperatively define the unit U in FIG. 67, can be readily assembled through a press fit operation. The interacting portions of the connector parts 666, 668; 672, 674 are robust and are guided into connected relationship without requiring the precise preparatory alignment and subsequent movement of conventional bi-pin structures. In the event the body 656 and/or one of the connector parts 666, 672 needs to be repaired or replaced, the connector part 666 can be released by squeezing the actuators 734, 734' together, whereupon the connector part 666 can be drawn away from the connector part 668 at one end of the body 656. The connector parts 672, 674 are released in like fashion at the opposite end of the body 656 to allow isolation of the unit U. Once that occurs, the unit U can be replaced in its entirety with a similar unit (not shown). Alternatively, one or both of the connector parts 666, 672 can be pulled lengthwise of the body 656 to effect separation to allow replacement, or access for repair, to any of the unit components 656, 666, 672. The absence of solder or other wire connections in preferred embodiments facilitates fast and simple disassembly and reassembly of the unit for this purpose. Thus, assembly of the unit U to the support 614, and separation of the unit U from the support 614 can be efficiently carried out. Through the assembly process, the body 656 becomes firmly mounted with the parts preferably configured so that there is an audible and/or tactile indication that the parts are fully engaged, which condition is not reliably determinable with the conventional bi-pin connection.

The above design, while described with a body 656 having a generally delta- or triangularly-shaped cross section, taken transversely to the length of the body 656, can be adapted to any body shape by conforming the end cap receptacle to be complementary to the peripheral body shape. For example, embodiments described above have different cross-sectional shapes with different numbers of sides (see, for example, the four-sided luminary in FIG. 5 and the five-sided luminary in FIG. 6). The connecting structure described in FIGS. 62-77 is adaptable to each of the earlier embodiments, and other shapes, by changing all of the connector parts to adapt to the different cross-sectional shapes for the corresponding bodies.

Still further, the connecting structures can be adapted to connector parts that are used on conventional round/cylindrical luminary shapes, typical of conventional fluorescent bulbs and many LED tubular bulbs. As seen in FIGS. 79 and

80, a connector part 666", corresponding to the connector part 666, can be made with a receptacle 686", corresponding to the receptacle 686, that is bounded by a cylindrical surface 760 that is complementary in shape and diameter to an outer surface 762 of a cylindrical luminary body 656". The body 656" can be translated parallel to its length to seat the body end 659" in the receptacle 686" and establish an electrical connection, through an end connector board 688", which in turn may be electrically connected through the connector part 668 to the power supply 680. The end connector board 688" may be substantially the same as the end connector board 688, differing only in shape to nest conformingly in the receptacle 686". Indicia, and/or keying structure may be provided on the connector part 666" and body 656" to allow an assembler to properly angularly align these parts for connection.

As depicted generally in FIG. 81, the first and third connector parts 666, 672 can be alternatively configured to cooperate with a conventional bi-pin arrangement 764 at the ends of a conventional fluorescent-type luminary, a luminary utilizing LEDs, or another design, with the body for such a generic luminary identified at 656". The bi-pins 764 cooperate with connector boards 688", corresponding to the connector boards 688, but modified to electrically connect to the bi-pins 764, preferably through a press fit step. The connector board 688" and first connector part 666 make up an end cap assembly 678" that cooperates with the second connector part 668 to: a) electrically connect to the power supply 680 through the connector components 692; 694, 696, respectively on the first and second connector parts 666, 668; and b) mechanically connect, as described above for these same connector parts 666, 668. The connector board 688" at the opposite body end connects to the bi-pin 764 in similar fashion, with the third and fourth connector parts 672, 674 mechanically connected as described above for these connector parts 672, 674. The details of the circuitry on the connector boards 688" to accommodate the bi-pin design would be readily devised by one skilled in the art in view of the disclosure herein.

In this manner, the disadvantages described above associated with conventional bi-pin bulbs and connectors may be overcome by retrofitting such bulbs with end connectors of the type disclosed in accordance with the invention, thereby permitting such bulbs to be installed on and mechanically and electrically connected to connectors of the type described as the second and fourth connector parts herein.

As explained above, the driver 300, including the driver board 380, may be eliminated. To depict this form of the invention, the driver 300 is shown in dotted lines in FIG. 70. Without the driver 300, the need for the terminal/surface mount driver connector 375 on the connector board 688 in FIG. 70 is obviated, as is the corresponding driver connector (not shown in FIG. 70) at the opposite end of the body 656 on the connector board 688'. Although shown for illustrative purposes in FIG. 70 near the second end 660 of body 656, the driver 300 may be mounted at any location along the length of the heat sink 297. When a single driver is utilized, it is preferably mounted near the first end 658 for connection to the surface mount connectors 375 of the end cap PCB connector 688.

Another variation from the embodiments described above relates to how the LED panels/emitter boards 293 are designed to be electrically connected to the power supply 680. Referring again to FIG. 70, which is representative of embodiments hereinabove described, the circuit for each of the emitter panels 293 is defined through the connector board 688', thereby necessitating electrical connection of

each emitter panel 293, that is carried out as the third connector 672 with the associated board 688' is press fit at the second end 660 of the body 656.

In an alternative design, as shown schematically in FIG. 82, wherein modified parts corresponding to those described above are identified with the same number and a "4" designation, the emitter panels 293⁴ are configured so that no electrical components are required within, or on, the third connector part 672⁴ to power the emitter panels 293⁴ from the supply 680. Instead, the electrical path between the connector components 694, 696, on the second connector part 668 connecting to the power supply 680, is completed adjacent to the second body end 660⁴ within the lengthwise extent of each of the body 656⁴ and the emitter panels 293⁴. This eliminates the need for the terminals 302 on the emitter panels 293⁴ at the second body end 660⁴ and the need for any electrical connecting components on either the third connector part 672⁴ or fourth connector part 674 to be electrically joined as the third connector part 672⁴ is press fit to the second body end 660⁴ and the fourth connector part 674. This modification potentially simplifies individual part design, reduces associated cost, and reduces the likelihood of an electrical failure caused during manufacture or assembly, or that might occur during use.

The body 656⁴ is otherwise mechanically connected to the first connector part 666⁴, and electrically connected through the first connector part 666⁴ to the second connector part 668, as with the earlier-described embodiments. For example, the electrical connection of the emitter panels 293⁴ may be effected through a connector board 688⁴ having associated connector components 692⁴. Terminals 302⁴ on the emitter panels 293⁴ are used to effect this connection.

An example of such an embodiment corresponding to the embodiment of FIG. 70 but with the emitter panel terminals and electrical components at the second body end 660 eliminated, is illustrated in FIG. 82a. In such an embodiment, the optional internal driver, if included, would typically be mounted near the first end 658 for connection to the surface mount connectors 375 of the end cap PCB connector 688.

Additional potential modifications are shown in FIG. 83, in which modified parts corresponding to those earlier described are identified with the same numbers together with a "5" designation.

In FIG. 83 a luminary body 656⁵ is depicted having a heat sink 297⁵ with a delta- or triangularly-shaped cross-section. The heat sink 297⁵ has two sides 294⁵, 295⁵ at which emitter panels 293⁵ (one shown) are placed, each with LED emitters 298⁵ at intervals along the length of the heat sink 297⁵.

The heat sink 297⁵ may be extrusion-formed to define elongate receptacles 766, 768 of like construction. Exemplary receptacle 768 is defined by a flat surface 770 with widthwise ends that blend into spaced, "U" shapes that define slots 772, 774 that open towards each other. The emitter panels 293⁵ are configured to slide lengthwise, one each, into the receptacles 766, 768. The emitter panels 293⁵ (one shown in the receptacle 766) are dimensioned so that the opposite emitter panel edges 776, 778, spaced widthwise of each other, seat simultaneously in the slots 772, 774. The relative dimensions of the emitter panels 293⁵ and receptacles 766, 768 are selected so that the emitter panels 293⁵ can be assembled to the heat sink without requiring imparting of potentially damaging forces thereto. At the same time, the fit is preferably sufficiently snug so that the emitter panels 293⁵ do not shift so easily that they are prone to

becoming misaligned lengthwise of the heat sink 297⁵ as the body 656⁵ is normally handled, either during shipping or assembly.

This design may simplify the assembly of the components on the body 656⁵ by permitting the union of the heat sink 297⁵ and emitter panels 293⁵ without the need for any separate fasteners or adhesive or the use of ribs, tabs or other structures extending from the inner surface of the diffuser cover to prevent the emitter panels from separating from the heat sink.

The relationship of the assembled emitter panels 293⁵ to the heat sink 297⁵ and diffuser cover 328⁵, as depicted in FIG. 83, may also enhance light intensity and distribution compared to earlier-described embodiments. The diffuser cover 354 in the embodiment in FIG. 17 is configured so that the base of the "U" shape, as seen in cross section, is adjacent to, or at, where the emitter panels 336, 337, 338 on angled sides of the heat sink 334 meet. On the other hand, as seen in FIG. 83, the base region of the heat sink 297⁵ at 780 is spaced a substantial distance D from a corresponding base region at 782 for the diffuser cover 328⁵.

Regardless of the light transmissive properties of the material defining the diffuser cover 328⁵, a certain amount of light from the LED emitters 298⁵ reflects back towards the emitter panels and will impact the emitter panels and the bottom surface 784 of the heat sink 297⁵ to be re-directed thereby within the space 786 outwardly towards the diffuser cover 328⁵. This reflected light, following the exemplary path indicated by the arrows A. The additional spacing between the lower regions of the heat sink 297⁵ and diffuser cover 328⁵, and removing the apex of the otherwise triangular heat sink cross section, as depicted, facilitates a more even distribution of the light reflected by the diffuser cover 328⁵ and intensifies the overall light pattern and may also enhance the uniformity of the light distribution pattern. Also, the receptacles 768, 766 described above secure the emitter panels 293⁵ without the need for additional structure such as the elongated rib shown at the base region of the diffuser cover 354 of FIG. 17. As such a rib may interfere with light transmission through the diffuser cover, eliminating the rib from the diffuser cover may further aid in providing a more even light distribution pattern emanating from the lighting assembly.

In FIGS. 84 and 85, a further modified form of heat sink 297⁶ is shown that is similar to the heat sink 297⁵ of FIG. 83, with the primary difference being that the base region 780⁶ is substantially flat, as is the surface 784⁶ at the bottom thereof. This design may also effectively increase light intensity and uniformity due to the re-direction of light that reflects from the diffuser cover 328⁶.

In both embodiments shown in FIGS. 83-85, the diffuser cover 328⁵, 328⁶ and heat sinks 297⁵, 297⁶ are configured to be connected in the same manner. As seen for exemplary diffuser cover 328⁶, the upper region of spaced legs 788, 790, that form part of a cross-sectional "U" shape for the diffuser cover 328⁶, can be flexed away from each other, as indicated by the arrows 792, thereby allowing rails 794, 796 to align vertically with complementary heat sink slots 798, 800, respectively. By then releasing the legs 788, 790, the residual forces, generated by the initial deformation, urge the legs 788, 790 towards their initial shape, whereupon the rails 794, 796 are urged into their respective slots 798, 800 to secure the diffuser cover 328⁶.

Alternatively, the undeformed diffuser cover 328⁶ can be aligned under the heat sink 297⁶ and pressed upwardly. As this occurs, the legs 788, 790, through a camming interaction between the rails 794, 796 and heat sink 297⁶, are urged

away from each other. Once the rails **794**, **796** vertically align with the slots **798**, **800**, the legs **788**, **790** spring back towards, or into, their undeformed state, seating the rails **794**, **796** in the slots **798**, **800**.

It may be desirable to maintain a certain level of the restoring forces in the legs **788**, **790** once the diffuser cover **328^{6'}** is assembled so that the diffuser cover **328^{6'}** embraces the heat sink **297^{6'}** and thus maintains its assembled position.

Alternatively, each of the diffuser covers **328^{5'}**, **328^{6'}** may be slid into its assembled state by aligning the ends of the rails **788**, **790** and slots **798**, **800**, as seen in the embodiment in FIGS. **84** and **85**, and thereafter effecting relative lengthwise translation of the diffuser cover **328^{6'}** until it is properly aligned.

In FIG. **86**, another modified form of heat sink is shown at **297^{7'}**. The heat sink **297^{7'}** has a shorter vertical profile in relationship to the vertical extent of the depicted diffuser cover **328^{7'}**, which may be the same as the diffuser cover **328^{6'}**. This design is adapted to applications in which a single emitter panel **293^{7'}** (or series of emitter panels placed end to end) is used. The increased distance and centralized location of the LEDs relative to the diffuser cover effectively increases the area that light transmitted from the emitter board to the diffuser cover and distributed by the diffuser cover. This tends to promote a more even form of light emanating from the lighting assembly and allowing for a glow affect. Such a design is also ideal for areas that require Cove type lighting and other applications in which the LED emitters are required to be hidden from view.

The depending heat sink sides **294^{7'}**, **295^{7'}** terminate at offset ends **808**, **810**, that project towards each other to define ledge portions **812**, **814**, respectively, that cooperatively support an emitter panel **293^{7'}** with LED emitters **298^{7'}**. A horizontal wall **816** spans between the sides **294^{7'}**, **295^{7'}** and bounds in conjunction with the offset ends **808**, **810**, a receptacle **818** into which the emitter panel **293^{7'}** can be directed. The emitter panel **293^{7'}** can be aligned at one end of the receptacle **818** and translated into a coextensive lengthwise relationship with the heat sink **297^{7'}**.

This design may accommodate emitter panels **293^{7'}** with a greater width *W* than is permitted within the same peripheral geometry of the embodiments depicted in FIGS. **83-85**, without altering their operating characteristics or performance. Embodiments of this type are particularly well adapted for emitter panels of AC powered LEDs because the greater width is available for mounting additional electronic components, such as rectifiers and filters, associated with AC LEDs. Regardless of the type of emitter panel used, the placement of the emitter panel **293^{7'}** as shown in FIG. **86** makes possible a wide dispersion pattern emanating from a location a substantial distance above the bottom of the diffuser cover **328^{7'}**. Alternatively, the vertical profile of the diffuser cover **328^{7'}** can be reduced from what is shown in FIG. **86**. Of course this embodiment, as well as all of the embodiments herein, are not limited to use of either AC- or DC-powered emitter panels.

As mentioned above, modern building codes and ordinances require that each public facility have a stand-alone emergency battery backup lighting system. This is to ensure the safety of the occupant of any said space that may be impacted by catastrophic power failure. Most buildings run the emergency lighting (EM) circuit from a designated EM lighting and or power panel. The circuits that are utilized from that panel cannot be interrupted and or shared with common circuits and must run in a dedicated conduit system and routed to only the intended EM light for the space that it is supporting. This can involve significant cost to install

dedicated battery backup lights, especially in a preexisting building. The EM circuit must be customized to each space to insure that EM lights are located by all exits and in rooms with no means of outside ambient light.

As a way to overcome these and other problems associated with conventional EM lighting systems, the multi-sided LED light bar of the invention may also be provided in the form of a self-contained LED luminary with its own internal stand-alone UPS battery backup system. FIG. **87** illustrates an example of such an embodiment. The body **656** has the basic components of the illuminating assembly/luminary shown in FIG. **82a** and described hereinabove. Generally, this construction consists of the three-sided delta, or triangularly-shaped, metal heat sink **297** with two LED emitter panels **293** positioned in a generally "V"-shape on the heat sink **297**. Each of the LED emitter boards/panels **293** has a plurality of LED emitters **298** spaced at generally uniform intervals along the length thereof between the ends **658**, **660** of the body **656**. Each of the LED emitter panels **293** has terminals **302** in the form of conductive components **682** projecting in a lengthwise direction from an end of the emitter panels **293**.

As described above, the first connector **664** is provided at the first end **658** of the body **656**, with the second connector **670** provided at the second end **660** of the body **656**. The first connector **664** consists of the first connector part **666**, that is part of the first end cap assembly **678**, and the second connector part **668**. The first end cap assembly **678** consists of a first, cup-shaped component **684** defining a first receptacle **686** opening towards the body **656** and into which the first end **658** of the body extends. The receptacle **686** receives an end connector board **688** which overlies a separate board **690** having L-shaped electrical connector components **692** thereon that cooperate with connector components **694**, **696** within wires that extend into the second connector part **668** to establish electrical connection between the boards **688**, **690** and the power supply **680**. The power supply **680** powers the lighting assembly during normal operations.

In this form, the lighting assembly of the invention further includes UPS battery circuit **900** mounted on an internal PCP **901** as shown within the hollow region defined by multi-sided heat sink **297**. As discussed in connection with other embodiments, an internal driver (not shown) may also be mounted internal to the heat sink **297** for converting AC power to DC and directing it the LED emitters **298** of the emitter boards **293**. The UPS battery backup circuit is operatively positioned and connected to the driver and includes a charging circuit which provides a charging current to the one or more batteries thereof when power source **680** is in normal operation. In the event that power from power source **680** is interrupted, a control sub-circuit of the UPS battery backup circuit switches the load to the battery back for powering the LEDs **298** of the lighting assembly as emergency lighting. In other embodiments, the circuits may be designed such that the lighting assembly is a dedicated emergency light which is dark during periods of normal power supply but receiving a charging current, and which illuminates under power of the UPS battery backup circuit **900** when the normal power supply is lost.

The available space within heat sink **297** will permit mounting a sufficient number of backup batteries to power the LEDs and provide the required illumination for durations required to meet applicable emergency lighting codes. Currently available UPS batteries sources should provide power for 15 minutes and up to at least 2 hours and potentially longer depending on the number and type of batteries

mounted within the hollow void of heat sink 297. It will be understood that this approach may be implemented in numerous other forms of the multi-sided heat sink of the invention, including, for example, four-sided and five-side heat sinks other particular forms.

By providing a tubular lighting assembly with a concealed UPS that can sustain its own source of power in the event of a power outage, this aspect of the invention provides numerous additional benefits. For example, an entire pathway of lighting can be generating to insure the most direct route out of a powerless building simply by installing the UPS emergency lights in conventional ballasts at strategically chosen locations. Because the UPS backup circuit is implemented internal to the lighting assembly, the exiting mounting fixture does not require any additional wiring or foreign components to be installed into the fixture. This aspect of the invention thus allows for buildings to be equipped with emergency safety lighting without the increase of cost of installing dedicated breakers, circuits, emergency lights, specialized ballasts, outside battery sources, generators and other equipment throughout the building, making it easier and more likely that building owners and property managers abide by the codes requiring adequate lighting in the event of a power loss. Because the UPS is concealed internal to the heat sink, aesthetics are not adversely affected.

Although embodiments of the invention have been shown and described, it is to be understood that various modifications, substitutions, and rearrangements of parts, components, and/or process (method) steps, as well as other uses, shapes, features and arrangements of light emitting diode (LED) illuminating assemblies provided with a multi-sided LED light bar comprising a non-curvilinear LED luminary, other heat sink designs disclosed herein, luminaries utilizing AC-driven LEDs, UPS back-up and/or novel end cap connector assemblies can be made by those skilled in the art without departing from the novel spirit and scope of this invention. Furthermore, one or more of the disclosed features of any of the disclosed embodiments can be combined with, added, or substituted for, one or more features of any of the other disclosed embodiments.

The foregoing disclosure of specific embodiments is intended to be illustrative of the broad concepts comprehended by the invention.

The invention claimed is:

1. An elongate tubular lighting assembly having a body with a length between spaced first and second ends, and configured to be installed in a light fixture comprising a single light socket, the tubular lighting assembly comprising:

an elongate multiple sided heat sink comprising at least first, second and third sidewalls defining a hollow interior region;

the first and second sidewalls comprising generally planar mounting portions lying in intersecting planes;

an outer surface of the third sidewall forming an outer surface of the body;

first and second LED emitter panels, the first LED emitter panel supported on the mounting portion of the first sidewall, the second LED emitter panel supported on the mounting portion of the second sidewall;

each LED emitter panel comprising at an arrangement of spaced LED emitters for emitting and distributing light outwardly from the emitter panel in a light distribution pattern;

an elongate light diffuser cover providing a light transmissive lens positioned about and covering the LED

emitters for reflecting, diffusing and/or focusing light emitted from the LED emitters;

a first end cap assembly positioned at a first end of the body, said first end cap assembly comprising a base portion configured to be inserted in a substantially straight linear path into an engaged position within a base receptacle of a light socket connected to an AC power supply;

the first end cap assembly further comprising a plurality of AC power pin connectors electrically connected to said first and second emitter panels, the AC power pin connectors extending from the base portion and external thereof in a direction generally parallel to the length of the body for engaging and electrically connecting to said socket.

2. The elongate tubular lighting assembly according to claim 1, wherein said LED emitters are DC powered LEDs and said lighting assembly further comprises at least one driver circuit mounted within the interior region of the heat sink for driving the LED emitters with a controlled level of electric current.

3. The elongate tubular lighting assembly according to claim 2, wherein the at least one driver circuit controls the current level provided to the LED emitters below a maximum current capacity thereof for providing more efficient conversion of electrical power to light output.

4. The elongate tubular lighting assembly according to claim 2, wherein the at least one driver circuit is at least one non-switching driver circuit.

5. The elongate tubular lighting assembly according to claim 2, wherein each LED emitter panel comprises first and second groups of LED emitters, the first group of LED emitters connected in parallel to the second group of LED emitters and the LED emitters of each group connected in series to the other LED emitters of the same group.

6. The elongate tubular lighting assembly according to claim 5, wherein the at least one driver circuit comprises multiple parallel driver subcircuits for driving all LED emitters at substantially the same current level.

7. The elongate tubular lighting assembly according to claim 1, wherein said LED emitters are AC powered LEDs.

8. The elongate tubular lighting assembly according to claim 7, said lighting assembly further comprises comprising control circuitry for controlling the AC current supplied to the AC powered LED emitters.

9. The elongate tubular lighting assembly according to claim 8, said control circuitry limiting the AC current supplied to the AC powered LED emitters below the maximum current capacity thereof for providing more efficient conversion of electrical power to light output.

10. The elongate tubular lighting assembly according to claim 1, further comprising a connector end board positioned within the first end cap assembly, the connector end board electrically connected to the first and second emitter panels and to the plurality of AC power pin connectors.

11. The elongate tubular lighting assembly according to claim 10, wherein the connector end board comprises a plurality of matingly engagable LED emitter panel connectors and each LED emitter panel comprises a corresponding matingly engagable connector for mechanically and electrically connecting the connector end board to the respective LED emitter panel.

12. The elongate tubular lighting assembly according to claim 11, wherein the corresponding matingly engagable connectors include a male connector adapted to plug into a female connector.

51

13. The elongate tubular lighting assembly according to claim 10, wherein the connector end board is electrically connected to the LED emitter panels in the absence of electrical wires.

14. The elongate tubular lighting assembly according to claim 1, further comprising a second end cap assembly positioned at a second end of the body, the second end cap assembly comprising an end wall extending traverse to the length of said body and multiple sides extending from the end wall along the length of the body and defining a receptacle opening receiving a second end of the body.

15. The elongate tubular lighting assembly according to claim 1, further comprising ridges or fins formed on the outer surface of the third side wall of the heat sink, the ridges or fins increasing the outer surface area of the heat sink to facilitate dissipating heat.

16. The elongate tubular lighting assembly according to claim 15, the multiple sided heat sink formed of extruded metal.

52

17. The elongate tubular lighting assembly according to claim 1, wherein the elongate tubular lighting assembly produces a light beam spread out over an angle of at least 210 degrees.

18. The elongate tubular lighting assembly according to claim 1, wherein the elongate tubular lighting assembly produces a light beam having a 1/2 brightness angle of at least 180 degrees.

19. The elongate tubular lighting assembly of according to claim 1, wherein the lighting fixture is an overhead ceiling lighting fixture and the lighting assembly is configured such that the LED emitter panels distribute light generally downwardly when the elongate tubular lighting assembly is installed in the light socket of the ceiling light fixture.

20. The elongate tubular lighting assembly according to claim 1, wherein said light diffuser cover has a generally U-shaped cross section.

* * * * *